



Agilent Technologies

Innovating the HP Way

June 8, 2000

Dear Customer,

As of November 1, 1999, four of Hewlett-Packard's businesses, test and measurement, semiconductor products, health care solutions, and chemical analysis became a new company, Agilent Technologies. Now, many of your Hewlett-Packard products and services are in the care of Agilent Technologies.

At Agilent Technologies, we are working diligently to make this transition as smooth as possible for you. However, as a result of this transition, the products and related documentation contained in this shipment may be labeled with either the Hewlett-Packard name and logo, the Agilent Technologies name and logo, or a combination of both. Information in this package may refer to Hewlett-Packard (HP), but applies to your Agilent Technologies product. Hewlett-Packard and Agilent branded products with the same model number are interchangeable.

Whatever logo you see, the information, products, and services come from the same reliable source.

If you have questions about Agilent Technologies products and services, please visit our website at <http://www.agilent.com>.

Sincerely,

Rebranding Team

HP 8902A MEASURING RECEIVER

8902A Operation and Calibration Manual
Part Number 08902-90029



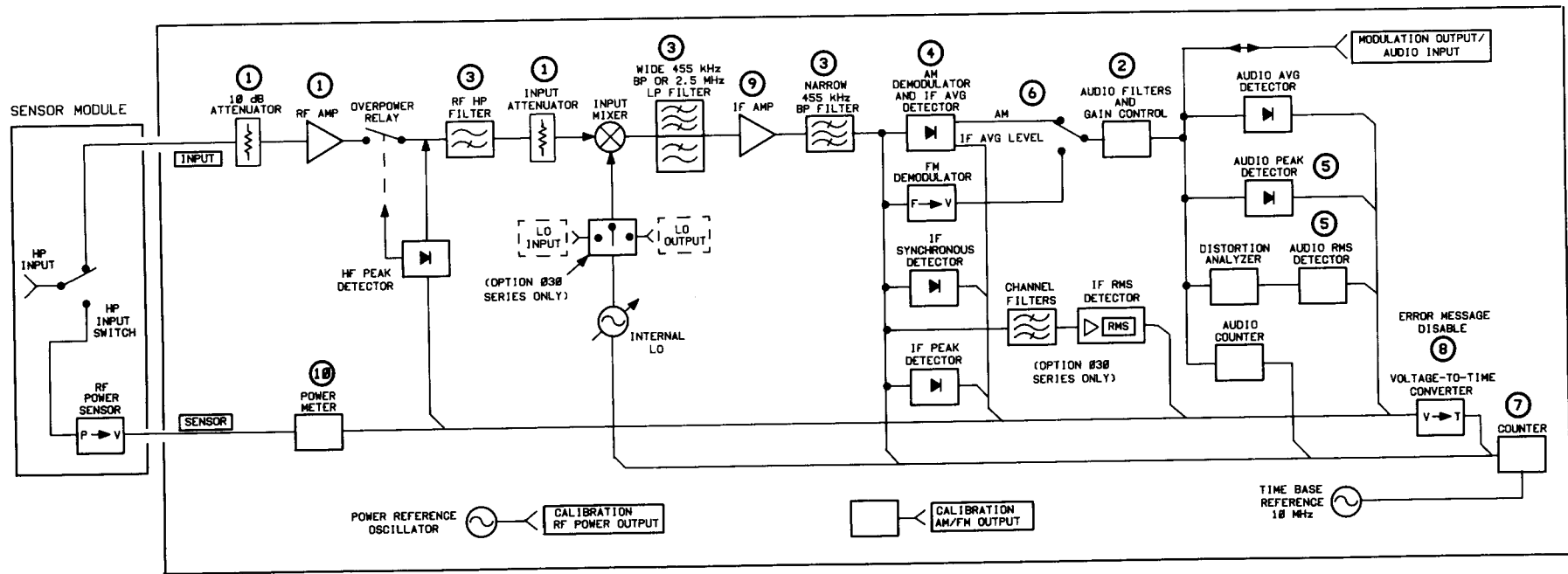

1. RF Input Attenuation and Gain

AUTO	RF Attenuation (dB)						RF Gain (dB)		AUTO*
	0	10	20	30	40	50	24	14	
1.0	1.1	1.2	1.3	1.4	1.5	1.6	1.7	1.8	1.9

* Automatic selection 10 dB attenuator always inserted (Tuned RF Level only).

6. Automatic Level Control*

Slow AM > 20 Hz	Fast AM > 1 kHz	Off
6.0	6.1	6.2

* Except Tuned RF Level

2. Audio Range

Modulation	Auto	Detector			
		RMS	Pk, Ave, RMS		
AM (% , pk)		4.0	40	100	100
FM (kHz, pk)*		0.4	4	40	400
ΦM (rad, pk)		0.4	4	40	400
	2.0	2.4	2.1 (2.4)	2.2	2.3

* Divide-by-10 with 750 μs FM DE-EMPHASIS and PRE-DISPLAY.

3. RF and IF Filters

IF FREQ	Auto	455 kHz		1.5 MHz	
		Bandwidth			
Wide Filter		2.5 MHz	200 kHz	2.5 MHz	
Narrow Filter		30 kHz Bandwidth		Narrow Filter Out	
RF HP Filter Out	3.0	3.6	3.5	3.1	3.2
RF HP Filter In		3.8	3.7	3.3	3.4

4. Tuned RF Level Detector Selection and Display Averaging

Detector	IF Synchronous			IF Average				
Measurement Averaging Time(s)	AUTO	10	1	0.1	AUTO	10	1	0.1
	4.0	4.1	4.2	4.3	4.4	4.5	4.6	4.7

5. Audio Detector Response

Audio Peak Detector Response and RMS Detector Digital Averaging Response:

Fast	Slow
5.0	5.1

7. RF Frequency Resolution

AUTO	10 Hz	100 Hz	1 kHz	1 Hz
7.0	7.1	7.2	7.3	7.4

8. Error Message Disable and Enable

Auto	Disable Errors							All Errors Enabled
	01	02	03	04	01	02	03	
		03	03		04	04	04	
8.0	8.1	8.2	8.3	8.4	8.5	8.6	8.7	8.8

9. IF Gain

IF Gain (dB)							
Auto	0	10	20	30	40	50	60
9.0	9.1	9.2	9.3	9.4	9.5	9.6	9.7

10. RF Power Range

AUTO	Most Sensitive Range			Least Sensitive Range	
	#1	#2	#3	#4	#5
10.0	10.1	10.2	10.3	10.4	10.5

11. Previous Ratio

11.2 Display previous ratio reference.

12/13. Calibration FM, AM

	Display Peak FM	Display Peak AM
Computed	12.0	13.0
Residual	12.1	13.1
Measured	12.2	13.2

14. Limit

14.0 Disable

14.9 Display limit status: Lower limit status. Upper (0=disabled, 1=enabled).

	Lower Limit	Upper Limit
Set to Ratio Reference	14.1	14.2
Enable	14.3	14.4
Display	14.5	14.6
Display Measurement Code	14.7	14.8

15. Time Base Check

15.0 Displays Error 12 if Option 002 is installed and oven is cold. Displays 0 if Option 002 is installed and oven is warm, or if Option 002 is not installed.

15.1 Displays 0 if internal time base is being used. Displays 1 if external time base is being used.

16. Calibration Factors: AM,

17. Calibration Factors: FM

	AM Cal Factor	FM Cal Factor
Disable	16.0	17.0
Enable	16.1	17.1
Display	16.2	17.2

18. Tone-Burst Receiver

18.NN Configures instrument as a tone-burst receiver. A time delay of NN ms is inserted between detection of a carrier and unsquelching of the output at MODULATION OUTPUT/AUDIO INPUT. Range of NN is 1 to 99 ms. If NN is 0, delay is 99 ms.

21. HP-IB Address

21.0 Displays HP-IB address in form AAAAAAA.TLS

AAAAAAA = binary address

T = 1 = talk only

L = 1 = listen only

S = 1 = requesting service

22. Service Request

22.NN A value of NN from 0 to 63 sums the weighted conditions below to set up a service request mask. The summed, weighted conditions are displayed when NN is 64.

- 1 Data Ready
- 2 HP-IB error (Cannot be disabled.)
- 4 Instrument error
- 8 Limit exceeded
- 16 Frequency Offset mode state change
- 32 Recal or Uncal
- 64 Read back SRQ mask

23. External LO (Option 030 Only)

23.0 Return the LO to internal.

23.1 Set the LO to external.

23.2 Display LO status: (0 = Internal, 1 = External)

24. Selective Power Measurement (Option 030 Only)

24.0 Sets the Measuring Receiver to the Selective Power Measurement Mode.

	Select	Establish 0 dB Ref.	Display Normalize Noise Meas.
Wide BW IF Filter (Adjacent-Channel, Cellular)	24.1	24.2	
Narrower BW IF Filter (Adjacent-Channel)	24.3	24.4	
Narrowest BW IF Filter (Single-Sideband Noise)	24.5	24.6	24.7

24.8 Sets the value of the noise measurement BW.

24.9 Display the value of the noise measurement BW.

25. External Attenuation (dB)

25.2 Display attenuation value.

26. Set Reference

- 26.0 Exit attenuator measurement
- 26.1 Re-enter attenuator measurement

27. Frequency Offset Control

Frequency Offset Mode		External LO	
Exit	Re-enter	Display	Enter/Enable
27.0	27.1	27.2	27.3

29/30. Other Audio Measurement Modes

- 29.0 SINAD
- 30.0 EXT AUDIO RMS LEVEL

31. Tuned RF Level Noise Correction

- 31.0 Turn off noise correction.
- 31.1 Turn on noise correction.
- 31.2 Display noise correction status (1 = Off, 0 = On).

32. dB and Frequency Resolution

- 32.0 Normal measurement resolution (Power: 0.01 dB resolution)
(Audio Frequencies from 100 to 250 kHz; 0.1 Hz resolution).
- 32.1 Increased measurement resolution (Power: 0.001 dB resolution)
(Audio Frequencies from 100 to 250 kHz; 0.1 Hz resolution).
- 32.2 Display measurement resolution status. (0 = normal,
1 = increased).

32.9 Tuned RF Level Measurements Using Track-Mode Tuning

1. Input a signal greater than -30 dBm.
2. Select 32.9 SPCL.
3. If using an external LO, enter the external LO frequency in MHz.
4. Select MHz to enter the manual tune mode.
5. Step the signal generator down in amplitude and press the CALIBRATE key whenever the RECAL annunciator is displayed.

33/36. Other Measurement Modes

- 33.0** LO FREQUENCY
- 34.0** IF FREQUENCY
- 35.0** RF LEVEL
- 36.0** PEAK TUNED RF LEVEL

37. Calibration Factors: RF Power

- 37.0** Automatic Cal Factors
- 37.1** Manual Cal Factors
- 37.2** Display Status (0 = auto, 1 = held)
- 37.3** *Enter frequency, cal factor
- 37.4** *Display table size
- 37.5** *Recall reference cal factor
- 37.6** *Recall next frequency, cal factor
- 37.7** *Clear Table

* Two tables are available. The table being used is determined by the status of the Frequency Offset mode (Special Function 27).

38/39. Calibration Factors Tuned RF Level

	RF Power to Range 1	Range 1 to 2	Range 2 to 3	SET REF Reference
Display	38.1	38.2	38.3	38.4
Enter	39.1	39.2	39.3	39.4

- 39.9** Clear all calibration factors.

Frequency Offset (Special Function 27).

The Frequency Offset mode allows the Measuring Receiver to keep track of frequencies involved in the down-conversion process. This frequency offset process is used in conjunction with an external mixer and Local Oscillator (LO) to extend the frequency coverage above 1300 MHz.

To enter the Frequency Offset mode:

2 7 . 3 + SPCL

+ LO Frequency + MHz

To exit the Frequency Offset mode:

2 7 . 0 + SPCL

To re-enter the Frequency Offset mode with the same LO frequency:

2 7 . 1 + SPCL

To display the external LO frequency:

2 7 . 2 + SPCL

Operating Error Codes

Display Code	To Solve an Input Problem	To Solve an Operating Problem
-- or 0 MHz	Adjust input signal level or change measurement sensitivity.	Decrease RF attenuation or gain.
-----	Manually tune to input signal.	Re-check operating conditions being used.
-----	Check tuning.	Re-check special operating conditions being used.
01	Increase input signal level or decrease AM.	Press the MHz key to center IF signal in IF passband. If problem persists, signal may be drifting.
02	Increase RF input attenuation.	Decrease RF and/or IF gain setting.
03	Increase level of input signal.	Decrease selected RF input attenuation or increase IF gain. If Range Hold is being used, check range limits.
04	Decrease modulation level on input signal to within measurement range.	Increase range limit setting, Special Function 2.N.
05	Increase carrier level or decrease AM depth (<90%).	
06	Input level exceeds 7 Vrms (1W peak). Decrease level of input signal. If making a TRFL measurement, also press the CLEAR key.	Decrease selected RF or IF gain. If Range Hold is being used, check range limits.
07	Decrease modulation level on input signal. If making a TRFL measurement, decrease level of input signal and press CLEAR key.	Decrease selected RF or IF gain. If Range Hold is being used, check range limits.
08	Check connection to Calibrator. Check for Calibrator malfunction.	
09		Check internal time base for malfunction (Option 002 only).
10	Adjust frequency of input signal to within measurement range, or increase measurement range. If making a TRFL measurement, set the input level to between 0 and -20 dBm. Select the Frequency mode. When the instrument displays the frequency of the input signal, press the MHz key and re-enter the TRFL mode.	

Operating Error Codes

Display Code	To Solve an Input Problem	To Solve an Operating Problem
11	Select linear (Watts) units, or disregard error when there is no power present at sensor input.	Key in a different ratio reference.
12		Wait for oven to warm for highest accuracy.
13	Secure connection at SENSOR input.	
14		Remove power from power sensor input during zeroing process.
15		Verify that cal factors have been entered.
16	Increase audio signal level.	
17	Input signal level during reference measurement must be between 1.25V and 2.50V.	Check selected RF or IF gain level. (When making Ratio measurements, allow instrument to complete the reference measurement.)
18		Check sensor connection at RF POWER OUTPUT port.
19		Increase IF gain.
20		Re-enter frequency within measurement range. (In Ratio mode, a reference measurement of zero is invalid.)
21		Check compatibility of function(s) with selected measurement mode.
22		Check Special Function number and re-enter (prefix invalid).
23		Check Special Function number and re-enter (suffix invalid).
24		Invalid HP-IB code. Check function codes.
25		Check Special Function compatibility with measurement.
26		End of RF Power calibration table. (If displayed after first attempt to read table using 37.6 SPCL, the table is empty.)

Operating Error Codes

Display Code	To Solve an Input Problem	To Solve an Operating Problem
30		Change RF attenuation and gain or Range Hold setting.
31		Calibrate RF Power measurement.
32		Change IF gain or Range Hold setting.
33	Maintain stable frequency and level during calibration. Check SENSOR connection.	Check RF Power calibration.
34	Maintain stable frequency during TRFL calibration.	
35	Use a stable signal source for TRFL calibration.	

Measuring Receiver Function to Code Summary

Function	Code	Function	Code
MEASUREMENTS		CALIBRATION	
AM	M1	CALIBRATE Off	C0
FM	M2	CALIBRATE On	C1
ΦM	M3	% CAL FACTOR	CF
RF POWER	M4	SET REF	RF
FREQ	M5	ZERO	ZR
AUDIO FREQ	S1	SAVE CAL	SC
AUDIO DISTN	S2		
IF LEVEL	S3	MANUAL OPERATIONS	
TUNED RF LEVEL	S4	AUTO TUNING	AT
FREQ ERROR	S5	ENABLE ERRORS	B0
		DISABLE ERRORS	B1
DETECTORS		CLEAR (KEY)	CL
PEAK+	D1	BLUE KEY, CLEAR (KEY)	BC
PEAK-	D2	DISPLAY FREQ	FR
PEAK HOLD	D3	DISPLAY INCREMENT	FN
AVG (RMS Calibrated)	D4	INPUT FREQUENCY (Hz)	HZ
1 kHz DISTN	D5	↑ Hz	HU
400 Hz DISTN	D6	↓ Hz	HD
RMS	D8	TRACK Mode Off (Lock Mode)	K0
PEAK±/2	D9	TRACK Mode On	K1
		↑ kHz	KU
DISPLAYS		↓ kHz	KD
Display LOG Result	LG	MHz (INPUT FREQ)	MZ
Display LIN Result	LN	RECALL	RC
dB EXT ATTEN off	N0	STORE	TR
dB EXT ATTEN on	N1	SPECIAL FUNCTION	SP
RATIO Off	R0	SPECIAL, SPECIAL	SS
RATIO On	R1	mV Units	MV
PREVIOUS RATIO	R2	μV Units	UV
		V Units	VL
FILTERS		W Units	WT
HP (High-Pass) FILTERS Off	H0	MISCELLANEOUS	
50 Hz FILTER On	H1	MODULATION OUTPUT	A0
300 Hz FILTER On	H2	AUDIO INPUT	A1
LP (Low-Pass) FILTERS Off	L0	AUTOMATIC OPERATION	AU
3 kHz FILTER On	L1	Auto-Ranging (RANGE HOLD Off)	G0
15 kHz FILTER On	L2	RANGE HOLD	G1
>20 kHz FILTER On	L3	Identify Instrument	ID
		INSTR PRESET (same as DCL)	IP
FM DE-EMPHASIS		Trigger Off	T0
PRE-DISPLAY Off and		Hold	T1
FM DE-EMPHASIS Off	P0	Trigger Immediate	T2
PRE-DISPLAY On and		Trigger with Settling	T3
FM DE-EMPHASIS On	P1	Hexidecimal A	X0
25 μs DE-EMPHASIS	P2	Hexidecimal B	X1
50 μs DE-EMPHASIS	P3	Hexidecimal C	X2
75 μs DE-EMPHASIS	P4	Hexidecimal D	X3
750 μs DE-EMPHASIS	P5	Hexidecimal E	X4
		Hexidecimal F	X5

Code to Measuring Receiver Function Summary

Code	Function	Code	Function
A0	MODULATION OUTPUT	M1	AM
A1	AUDIO INPUT	M2	FM
AT	AUTO TUNING	M3	ΦM
AU	AUTOMATIC OPERATION	M4	RF POWER
B0	ENABLE ERRORS	M5	FREQ
B1	DISABLE ERRORS	MV	mV Units
BC	BLUE KEY, CLEAR (KEY)	MZ	MHz (INPUT FREQ)
C0	CALIBRATE Off	N0	dB EXT ATTEN Off
C1	CALIBRATE On	N1	dB EXT ATTEN On
CF	% CAL FACTOR	P0	PRE-DISPLAY Off and FM DE-EMPHASIS Off
CL	CLEAR (KEY)	P1	PRE-DISPLAY On and DE-EMPHASIS On
D1	PEAK+	P2	25 μs DE-EMPHASIS
D2	PEAK-	P3	50 μs DE-EMPHASIS
D3	PEAK HOLD	P4	75 μs DE-EMPHASIS
D4	AVG (RMS Calibrated)	P5	750 μs DE-EMPHASIS
D5	1 kHz DISTN	R0	RATIO Off
D6	400 Hz DISTN	R1	RATIO On
D8	RMS	R2	PREVIOUS RATIO
D9	PEAK±/2	RC	RECALL
FR	DISPLAY FREQ	RF	SET REF
FN	DISPLAY INCREMENT	S1	AUDIO FREQ
G0	Auto-Ranging (RANGE HOLD Off)	S2	AUDIO DISTN
G1	RANGE HOLD	S3	IF LEVEL
H0	HP (High-Pass) FILTERS Off	S4	TUNED RF LEVEL
H1	50 Hz FILTER On	S5	FREQ ERROR
H2	300 Hz FILTER On	SC	SAVE CAL
HU	↑ Hz	SP	SPECIAL FUNCTION
HD	↓ Hz	SS	SPECIAL, SPECIAL
HZ	INPUT FREQUENCY (Hz)	T0	Trigger Off
ID	Identify Instrument	T1	Hold
IP	INSTR PRESET (same as DCL)	T2	Trigger Immediate
K0	TRACK Mode Off (lock mode)	T3	Trigger with Settling
K1	TRACK Mode On	TR	STORE
KU	↑ kHz	UV	μV Units
KD	↓ kHz	VL	V Units
L0	LP (Low-Pass) FILTERS Off	WT	W Units
L1	3 kHz FILTER On	X0	Hexidecimal A
L2	15 kHz FILTER On	X1	Hexidecimal B
L3	>20 kHz FILTER On	X2	Hexidecimal C
LG	Display LOG Result	X3	Hexidecimal D
LN	Display LIN Result	X4	Hexidecimal E
		X5	Hexidecimal F
		ZR	ZERO

HP 8901A/02A Code Differences

HP 8901A	HP 8902A	Functions
A1 (or AU)	AU	AUTOMATIC OPERATION
F1 (or MZ)	MZ	MHz (INPUT FREQ)
F2 (or KU)	KU	↑ kHz
F3 (or KD)	KD	↓ kHz
F4 (or Z4 or SP)	SP	SPECIAL
F5 (or Z5 or SS)	SS	SPECIAL, SPECIAL
K1 (or CL)	CL	CLEAR
U1 (or D1)	D1	PEAK+
U2 (or D2)	D2	PEAK-
U3 (or D3)	D3	PEAK HOLD
U4 (or D4)	D4	Average Detector (RMS Calibrated)
Z1 (or HZ)	HZ	Hz INPUT FREQ
Z2 (or HU)	HU	↑ Hz
Z3 (or HD)	HD	↓ Hz
M4	35.0SP	Peak RF Level
S4	36.0SP	Peak Tuned RF Level
R1	LN, R1	% RATIO
R2	LG, R1	dB RATIO
4.0SP	AT, K0	Auto Tuning, low-noise lock mode
4.1SP	AT, K1	Auto Tuning, track mode
4.2SP	MZ, K0	Manual Tuning, low-noise lock mode
7.1SP	7.1SP	10 Hz frequency resolution
7.2SP	7.3SP	1000 Hz frequency resolution
9.0SP	G1	Hold Setting (RANGE HOLD)
10.0SP	34.0SP	IF Frequency
11.0SP	LN, R2	% PREVIOUS RATIO
11.1SP	LG, R2	dB PREVIOUS RATIO
11.3SP	use "-" key	Make Ratio Reference Negative
15.0SP	15.0SP	Oven Check (returns "0" if oven OK or not installed, rather than doing nothing as in the 8901A)
Status Byte	Status Byte	Status Byte Bits "Upper Limit" (weight 8) and "Lower Limit" (weight 16) are merged together into "Limit Reached" (weight 8)



Agilent Technologies

Innovating the HP Way

June 8, 2000

Dear Customer,

As of November 1, 1999, four of Hewlett-Packard's businesses, test and measurement, semiconductor products, health care solutions, and chemical analysis became a new company, Agilent Technologies. Now, many of your Hewlett-Packard products and services are in the care of Agilent Technologies.

At Agilent Technologies, we are working diligently to make this transition as smooth as possible for you. However, as a result of this transition, the products and related documentation contained in this shipment may be labeled with either the Hewlett-Packard name and logo, the Agilent Technologies name and logo, or a combination of both. Information in this package may refer to Hewlett-Packard (HP), but applies to your Agilent Technologies product. Hewlett-Packard and Agilent branded products with the same model number are interchangeable.

Whatever logo you see, the information, products, and services come from the same reliable source.

If you have questions about Agilent Technologies products and services, please visit our website at <http://www.agilent.com>.

Sincerely,

Rebranding Team

HP 8902A MEASURING RECEIVER

Operation and Calibration Manual

SERIAL NUMBERS

This manual provides complete information for instruments with serial-number prefixes:

2305A to 2914A and all *MAJOR* changes that apply to your instrument.

rev. 01OCT92

For additional important information about serial numbers, refer to "INSTRUMENTS COVERED BY THIS MANUAL" in Section 1.

Sixth Edition

This material may be reproduced by or for the U.S. Government pursuant to the Copyright License under the clause at DFARS 52.227-7013 (APR 1988).

Copyright © HEWLETT-PACKARD COMPANY 1985
EAST 24001 MISSION AVENUE, TAF C-34, SPOKANE, WASHINGTON, U.S.A. 99220

Operation and Calibration Manual HP Part 08902-90029

Other Documents Available:

Basic Operation and Application Guide HP Part 5953-8458

Quick Reference Guide HP Part 08902-90060

Service Manual HP Part 08902-90031

Microfiche Operation and Calibration Manual HP Part 08902-90030

Microfiche Service Manual HP Part 08902-90032

Printed in U.S.A. : November 1994



1 Regulatory Information

(Updated March 1999)

Safety Considerations

GENERAL

This product and related documentation must be reviewed for familiarization with safety markings and instructions before operation.

This product has been designed and tested in accordance with *IEC Publication 1010*, "Safety Requirements for Electronic Measuring Apparatus," and has been supplied in a safe condition. This instruction documentation contains information and warnings which must be followed by the user to ensure safe operation and to maintain the product in a safe condition.

SAFETY EARTH GROUND

A uninterruptible safety earth ground must be provided from the main power source to the product input wiring terminals, power cord, or supplied power cord set.

SAFETY SYMBOLS



Indicates instrument damage can occur if indicated operating limits are exceeded.



Indicates hazardous voltages.



Indicates earth (ground) terminal

WARNING **A WARNING note denotes a hazard. It calls attention to a procedure, practice, or the like, which, if not correctly performed or adhered to, could result in personal injury. Do not proceed beyond a WARNING sign until the indicated conditions are fully understood and met.**

CAUTION A CAUTION note denotes a hazard. It calls attention to an operation procedure, practice, or the like, which, if not correctly performed or adhered to, could result in damage to or destruction of part or all of the product. Do not proceed beyond an CAUTION note until the indicated conditions are fully understood and met.

Safety Considerations for this Instrument

- WARNING** This product is a Safety Class I instrument (provided with a protective earthing ground incorporated in the power cord). The mains plug shall only be inserted in a socket outlet provided with a protective earth contact. Any interruption of the protective conductor inside or outside of the product is likely to make the product dangerous. Intentional interruption is prohibited.
- Whenever it is likely that the protection has been impaired, the instrument must be made inoperative and be secured against any unintended operation.
- If this instrument is to be energized via an auto transformer (for voltage reduction), make sure the common terminal is connected to the earth terminal of the power source.
- If this product is not used as specified, the protection provided by the equipment could be impaired. This product must be used in a normal condition (in which all means for protection are intact) only.
- No operator serviceable parts in this product. Refer servicing to qualified personnel. To prevent electrical shock, do not remove covers.
- Service instructions are for use by qualified personnel only. To avoid electrical shock, do not perform any servicing unless you are qualified to do so.
- The opening of covers or removal of parts is likely to expose dangerous voltages. Disconnect the product from all voltage sources while it is being opened.
- The power cord is connected to internal capacitors that may remain live for 5 seconds after disconnecting the plug from its power supply.
- For Continued protection against fire hazard, replace the line fuse(s) only with 250 V fuse(s) or the same current rating and type (for example, normal blow or time delay). Do not use repaired fuses or short circuited fuseholders.
- Always use the three-prong ac power cord supplied with this product. Failure to ensure adequate earth grounding by not using this cord may cause product damage.
- This product is designed for use in Installation Category II and Pollution Degree 2 per *IEC 1010* and *IEC 664* respectively. **FOR INDOOR USE ONLY.**
- This product has autoranging line voltage input, be sure the supply voltage is within the specified range.

To prevent electrical shock, disconnect instrument from mains (line) before cleaning. Use a dry cloth or one slightly dampened with water to clean the external case parts. Do not attempt to clean internally.

Ventilation Requirements: When installing the product in a cabinet, the convection into and out of the product must not be restricted. The ambient temperature (outside the cabinet) must be less than the maximum operating temperature of the product by 4° C for every 100 watts dissipated in the cabinet. If the total power dissipated in the cabinet is greater than 800 watts, then forced convection must be used.

Product Markings

CE - the CE mark is a registered trademark of the European Community. A CE mark accompanied by a year indicated the year the design was proven.

CSA - the CSA mark is a registered trademark of the Canadian Standards Association.

CERTIFICATION

Hewlett-Packard Company certifies that this product met its published specifications at the time of shipment from the factory. Hewlett-Packard further certifies that its calibration measurements are traceable to the United States National Bureau of Standards, to the extent allowed by the Bureau's calibration facility, and to the calibration facilities of other International Standards Organization members.

WARRANTY

This Hewlett-Packard instrument product is warranted against defects in material and workmanship for a period of one year from date of shipment. During the warranty period, Hewlett-Packard Company will at its option, either repair or replace products which prove to be defective.

For warranty service or repair, this product must be returned to a service facility designated by HP. Buyer shall prepay shipping charges to HP and HP shall pay shipping charges to return the product to Buyer. However, Buyer shall pay all shipping charges, duties, and taxes for products returned to HP from another country.

HP warrants that its software and firmware designated by HP for use with an instrument will execute its programming instructions when properly installed on that instrument. HP does not warrant that the operation of the instrument, or software, or firmware will be uninterrupted or error free.

LIMITATION OF WARRANTY

The foregoing warranty shall not apply to defects resulting from improper or inadequate maintenance by Buyer, Buyer-supplied software or interfacing, unauthorized modification or misuse, operation outside of the environmental specifications for the product, or improper site preparation or maintenance.

NO OTHER WARRANTY IS EXPRESSED OR IMPLIED. HP SPECIFICALLY DISCLAIMS THE IMPLIED WARRANTIES OF MERCHANTABILITY AND FITNESS FOR A PARTICULAR PURPOSE.

EXCLUSIVE REMEDIES

THE REMEDIES PROVIDED HEREIN ARE BUYER'S SOLE AND EXCLUSIVE REMEDIES. HP SHALL NOT BE LIABLE FOR ANY DIRECT, INDIRECT, SPECIAL, INCIDENTAL, OR CONSEQUENTIAL DAMAGES, WHETHER BASED ON CONTRACT, TORT, OR ANY OTHER LEGAL THEORY.

ASSISTANCE

Product maintenance agreements and other customer assistance agreements are available for Hewlett-Packard products.

For any assistance, contact your nearest Hewlett-Packard Sales and Service Office. Addresses are provided at the back of this manual.

SAFETY CONSIDERATIONS

GENERAL

This product and related documentation must be reviewed for familiarization with safety markings and instructions before operation.

This product is a Safety Class I instrument (provided with a protective earth terminal).

BEFORE APPLYING POWER

Verify that the product is set to match the available line voltage and the correct fuse is installed.

SAFETY EARTH GROUND

An uninterruptible safety earth ground must be provided from the main power source to the product input wiring terminals, power cord, or supplied power cord set.

SAFETY SYMBOLS



Instruction manual symbol: the product will be marked with this symbol when it is necessary for the user to refer to the instruction manual (refer to Table of Contents).



Indicates hazardous voltages.



Indicates earth (ground) terminal.

WARNING

The WARNING sign denotes a hazard. It calls attention to a procedure, practice, or the like, which, if not correctly performed or adhered to, could result in personal injury. Do not proceed beyond a WARNING sign until the indicated conditions are fully understood and met.

CAUTION

The CAUTION sign denotes a hazard. It calls attention to an operating procedure, practice, or the like, which, if not correctly performed or adhered to, could result in damage to or destruction of part or all of the product. Do not proceed beyond a CAUTION sign until the indicated conditions are fully understood and met.

WARNING

Any interruption of the protective (grounding) conductor (inside or outside the instrument) or disconnecting the protective earth terminal will cause a potential shock hazard that could result in personal injury. (Grounding one conductor of a two conductor outlet is not sufficient protection).

Whenever it is likely that the protection has been impaired, the instrument must be made inoperative and be secured against any unintended operation.

If this instrument is to be energized via an autotransformer (for voltage reduction) make sure the common terminal is connected to the earth terminal of the power source.

Servicing instructions are for use by service-trained personnel only. To avoid dangerous electric shock, do not perform any servicing unless qualified to do so.

Adjustments described in the manual are performed with power supplied to the instrument while protective covers are removed. Energy available at many points may, if contacted, result in personal injury.

Capacitors inside the instrument may still be charged even if the instrument has been disconnected from its source of supply.

For continued protection against fire hazard, replace the line fuse(s) only with 250V fuse(s) of the same current rating and type (for example, normal blow, time delay, etc.). Do not use repaired fuses or short circuited fuseholders.

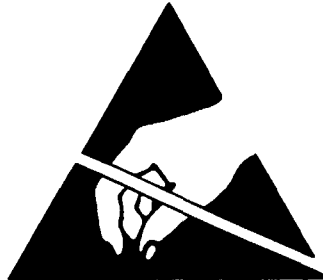

ATTENTION
Static Sensitive
Devices

This instrument was constructed in an ESD (electrostatic discharge) protected environment. This is because most of the semiconductor devices used in this instrument are susceptible to damage by static discharge.

Depending on the magnitude of the charge, device substrates can be punctured or destroyed by contact or mere proximity of a static charge. The results can cause degradation of device performance, early failure, or immediate destruction.

These charges are generated in numerous ways such as simple contact, separation of materials, and normal motions of persons working with static sensitive devices.

When handling or servicing equipment containing static sensitive devices, adequate precautions must be taken to prevent device damage or destruction.

Only those who are thoroughly familiar with industry accepted techniques for handling static sensitive devices should attempt to service circuitry with these devices.

In all instances, measures must be taken to prevent static charge build-up on work surfaces and persons handling the devices.

For further information on ESD precautions, refer to "SPECIAL HANDLING CONSIDERATIONS FOR STATIC SENSITIVE DEVICES" in Section 8, Service.

CONTENTS

Section 1 General Information

Introduction to This Manual	1-1
Specifications	1-2
Safety Considerations	1-2
Recommended Test Equipment	1-2
Instruments Covered by This Manual	1-2
Documentation Updating	1-2
Hewlett-Packard Interface Bus (HP-IB)	1-3
Additional Equipment Information	1-3
Description of the Measuring Receiver	1-6
Principles of Operation Using a Simplified Block Diagram	1-9
Modulation Basics	1-12

Section 2 Installation

Introduction to This Section	2-1
Initial Inspection	2-1
Preparation for Use	2-1
Storage and Shipment	2-9

Section 3 Operation

Introduction to This Section	3-1
Operating Characteristics of the Measuring Receiver	3-2
Operator's Information	3-2
Turn-On Procedure	3-3
Instrument Features	3-4
Remote Section Contents	3-11
Basic Functional Checks of the Measuring Receiver	3-47
Basic Functional Checks of the Hewlett-Packard Interface Bus (HP-IB)	3-59
Detailed Operating Instructions	3-71
RF Power and Level Contents	3-73
Frequency Measurements (RF, LO, IF) Contents	3-135
Modulation Measurements Contents	3-159
Audio Measurements Contents	3-225
Additional Capabilities Contents	3-235

Section 4 Performance Tests

Table of Contents	4-0
-----------------------------	-----

Section 5 Adjustments

Table of Contents	5-0
-----------------------------	-----

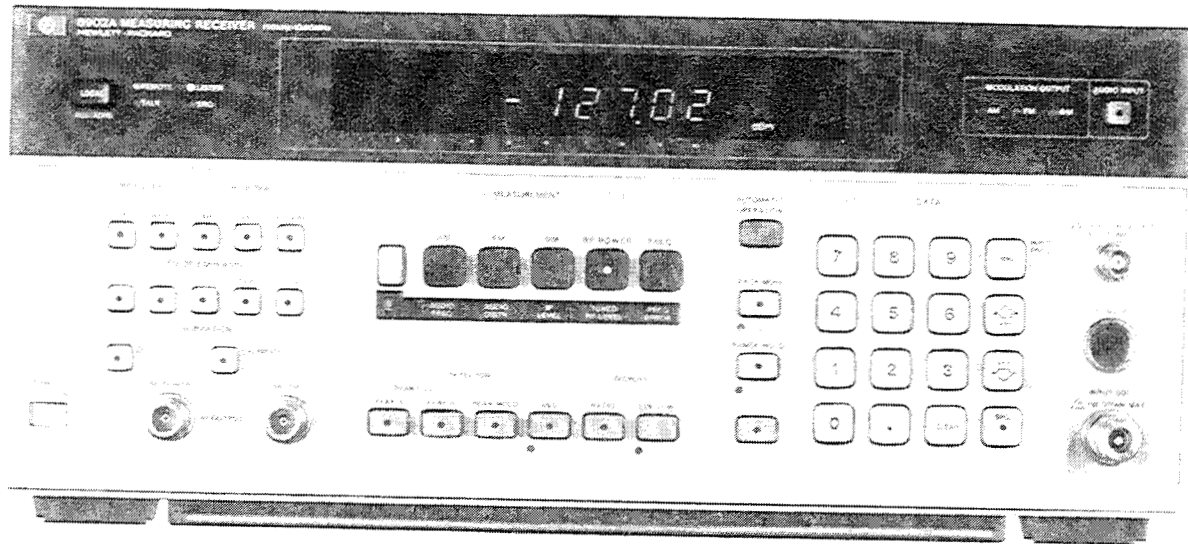

MODEL 8902A

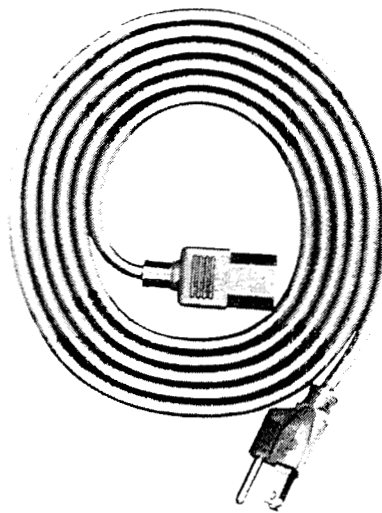

LINE POWER CABLE

Figure 1-1. HP 8902A Measuring Receiver and Supplied Accessories

Section 1

GENERAL INFORMATION

1-1. INTRODUCTION TO THIS MANUAL

The HP 8902A *Operating and Service Manual* is comprised of an *Operation and Calibration Manual* and the three volume *Service Manual*. These four volumes contain all the information required to install, operate, test, adjust, and service the Hewlett-Packard Model 8902A Measuring Receiver.

The information to operate and service this instrument is made available as follows: Sections 1 through 5 are contained in the *Operation and Calibration Manual* (that includes the *Basic Operation and Application Guide*) which is provided with each instrument. Sections 6 through 8 are contained in the *Service Manual* that is not included with the instrument but which can be obtained by mailing in the *Service Manual Request Card* included in this manual.

The Measuring Receiver is shown in Figure 1-1 with all supplied accessories. These manuals document Measuring Receivers supplied with Options 001, 002, 003, 004, series 030 and 050.

Operation and Calibration Manual

Section 1, General Information describes the instruments documented by this manual and covers instrument description, options, accessories, specifications and other basic information. This section also contains instrument theory of operation on a simplified block diagram level.

Section 2, Installation provides information about initial inspection, preparation for use (including address selection for remote operation), and storage and shipment.

Section 3, Operation provides information about panel features and includes operating checks, and operating instructions for both local and remote operation.

Section 4, Performance Tests provides the information required to check performance of the instrument against the critical specifications in Table 1-1.

Section 5, Adjustments provides the information required to properly adjust the instrument.

Service Manual

Section 6, Replaceable Parts provides ordering information for all replaceable parts and assemblies.

Section 7, Instrument Changes provides backdating information, and retrofitting and modification information.

Section 8, Service provides the information required to repair the instrument.

Additional copies of the *Operation and Calibration Manual* or the *Service Manual* can be ordered separately through your nearest Hewlett-Packard office. The part numbers are listed on the title page of this manual.

1-2. SPECIFICATIONS

Instrument specifications are listed in Table 1-1. These are the performance standards, or limits, against which the instrument may be tested. Information listed in this table as *Supplemental Characteristics*, are not warranted specifications but are typical characteristics included as additional information for the user.

1-3. SAFETY CONSIDERATIONS

This product is a Safety Class I instrument (that is, provided with a protective earth terminal). The Measuring Receiver and all related documentation must be reviewed for familiarization with safety markings and instructions before operation. Refer to the *Safety Considerations* page found at the beginning of this manual for a summary of the safety information.

Safety information pertinent to the task at hand (installation, operation, performance testing, adjustment or service) is found throughout these manuals.

1-4. RECOMMENDED TEST EQUIPMENT

Table 1-2 lists the test equipment and accessories recommended for use in testing, adjusting, and servicing the Measuring Receiver. If any of the recommended equipment is unavailable, instruments with equivalent minimum specifications may be substituted. Table 1-2 also includes some alternate equipment listings. Table 1-3 lists a number of accessories required in addition to those contained in the Service Accessory Kit, HP 08901-60287.

1-5. INSTRUMENTS COVERED BY THIS MANUAL

Options

Electrical options 001, 002, 003, 004, series 030, 050, and various mechanical options are documented in these manuals. The differences are noted under paragraph 1-8, *Options*, in Table 6-3, *Replaceable Parts*, and in the schematic diagrams in Section 8.

Serial Numbers

Attached to the instrument is a serial number plate. The serial number is in the form 1234A00123. The first four digits and the letter are the serial prefix. The last five digits form the sequential suffix that is unique to each instrument. The contents of these manuals apply directly to instruments having the same serial number prefix(es) as listed under SERIAL NUMBERS on the respective manual title pages.

For information concerning a serial number prefix not listed on the title page or in the Manual Changes supplement, contact your nearest Hewlett-Packard office.

1-6. DOCUMENTATION UPDATING

An instrument manufactured after the printing of these manuals may have a serial number prefix that is not listed on the manual title page. Having a serial number prefix that is greater than that shown on the title page indicates that the instrument is slightly different from those documented in the manual. In this case, your manual is provided with updating information to make it as current as possible. This updating information includes any hardware or software changes that have occurred as well as corrections to the documentation.

A Description of the Manual Update Packet

A *Manual Update* packet consists of replacement and addition pages which should be incorporated in your manual to bring it up to date.

Signing Up for the Documentation Update Service

Hewlett-Packard offers a Documentation Update Service that will provide you with further updates and changes as they become available. If you have not received update information that matches the serial number of your instrument, you can receive this information through the Update Service.

If you operate or service instruments with different serial prefixes, we strongly recommend that you join this service immediately to ensure that your manual is kept current. For more information, refer to the Documentation Update Service reply card included in this manual or contact:

Hewlett-Packard Company
 Technical Writing Department
 24001 E. Mission—TAF C-34
 Spokane, WA 99220
 (509) 922-4001

Also, if you join the update service, you can indicate whether you choose to be contacted in the future about the quality of the documentation you receive. We are trying to improve the documentation we provide and periodically survey customers as to their expectations of the manuals.

1-7. HEWLETT-PACKARD INTERFACE BUS (HP-IB)

Compatibility

The Measuring Receiver's capabilities are defined by the following interface functions: SH1, AH1, T5, TE0, L3, LE0, SR1, RL1, PP0, DC1, DT1, C0. The Measuring Receiver interfaces with the bus via open-collector TTL circuitry. An explanation of the compatibility code may be found in IEEE Standard 488-1978, *IEEE Standard and Digital Interface for Programmable Instrumentation* or the identical ANSI Standard MC1.1.

For more detailed information relating to programmable control of the Measuring Receiver, refer to *Remote Operation, Hewlett-Packard Interface Bus* in Section 3 of this *Operating Information* manual.

Selecting the HP-IB Address

The HP-IB address switches are located within the Measuring Receiver. The switches represent a five-bit binary number. This number represents the talk and listen address characters which controller must generate. In addition, two more switches allow the Measuring Receiver to be set to talk only or to listen only. A table in Section 2 shows all HP-IB talk and listen addresses. Refer to *HP-IB Address Selection* in Section 2 of this *Operation and Calibration* manual.

1-8. ADDITIONAL EQUIPMENT INFORMATION

Options

Options are variations on the standard instrument which can be ordered during the purchase. The following list defines all currently available options. Refer to *Electrical Equipment Available* in this section for retrofit part numbers that can be ordered after the purchase.

Option 001 This option provides rear-panel (instead of front-panel) connections for RF INPUT, SENSOR input, MODULATION OUTPUT/AUDIO INPUT, and AM/FM and RF POWER CALIBRATION OUTPUTs.

Option 002 This option provides a high-stability (1×10^{-9} /day) internal reference oscillator in place of the standard reference oscillator. In addition, a 10 MHz time base output is provided on the rear panel.

Option 003 This option provides both an output for the internal local oscillator signal and an input for an external local oscillator signal. Both connections are located on the rear panel. (This output is provided automatically with option 030 series instruments.)

Option 004 This option allows operation at line frequencies ranging from 48 to 400 Hz. Operation at frequencies greater than 66 Hz is restricted to less than 126.5 Vac line input.

Option 030 The High Selectivity Measurement option provides the capability to measure single-sideband carrier noise (AM or phase) quickly and accurately up to 1.3 GHz with an external LO. (An output for the internal local oscillator and an input for an external local oscillator signal is provided with these options.) This option is ordered with one of the following filter options:

Option 032 This option provides a 12.5 kHz adjacent channel filter.

Option 033 This option provides a 25 kHz adjacent channel filter.

Option 035 This option provides a 30 kHz (Cellular Radio) alternate channel filter.

Option 037 This option provides a carrier noise filter.

Option 050 This option provides increased power measurement accuracy.

Options 907-909 These options are described in *Mechanical Equipment Available*.

Option 910 This option provides an extra copy of the *Operation and Calibration Manual*, the *Service Manual*, and the *Quick Reference Guide*.

Accessories Supplied

The Accessories Supplied are pieces of equipment which are shipped automatically with every Measuring Receiver.

Line Power Cable The line power cable may be supplied in several plug configurations, depending on the destination of the original shipment. Refer to *Power Cables* in Section 2 of this *Operating Information* manual.

Fuses Fuses with a 2.5A rating for 115 Vac (HP 2110-0083) and a 1.5A rating for 230 Vac (HP 2110-0043) are supplied. One fuse is factory installed according to the voltage available in the country of original destination. Refer to *Line Voltage and Fuse Selection* in Section 2 of this *Operating Information* manual.

Electrical Equipment Available

This equipment is available to be ordered for the Measuring Receiver after the time of sale.

HP-IB Controller The Measuring Receiver has an HP-IB interface and can be used with any HP-IB compatible computing controller or computer for automatic systems applications.

Sensor Module The HP 11722A and 11792A Sensor Modules enable you to characterize a signal using a single input connector. Switching back and forth between the Measuring Receiver's SENSOR input and RF INPUT connectors happens automatically with these modules (which contain an internal switch). The HP 11722A covers the frequency range 100 kHz to 2.6 GHz; the HP 11792A covers the range 50 MHz to 26.5 GHz and is intended for use with the HP 11793A Down Converter. Special care is taken with each sensor module to minimize input SWR and resulting errors. A low SWR attenuator isolates the power sensor from the source-under-test, reducing mismatch. Microwave hardware and a selected RF input cable further improve SWR and insertion loss.

Down Converter The HP 11793A Down Converter, when used with a suitable local oscillator, extends the useful range of the Measuring Receiver into the microwave region. Provisions have been made in the Measuring Receiver to account for the frequency of the local oscillator and provide direct display of the frequency of the microwave input signal.

Test Source The HP 11715A AM/FM Test Source produces extremely linear AM and FM at high rates as well as a low-noise CW signal. This source is required for performance testing and adjusting the Measuring Receiver; however, it is an excellent stand-alone instrument for generating very low-distortion FM in the broadcast band.

Verification Kit A Verification Kit (HP 11812A) is available (which contains a step attenuator, two 10 dB pads, and cable) for verifying the performance of the HP 8902A Option 050 Tuned RF Level function to reduced specifications.

Service Accessory Kit A Service Accessory Kit (HP 08901-60287) is available which contains accessories (such as extender boards and cables) useful in servicing the Measuring Receiver.

Front-to-Rear-Panel Connectors Retrofit Kit (Option 001) This kit contains all the necessary components and full instructions for converting front-panel connections to rear-panel connections. Order HP part number 08902-60026.

Rear-to-Front-Panel Connectors Retrofit Kit (Standard) This kit contains all the necessary components and full instructions for converting Option 001 instruments with rear-panel connections to instruments with front-panel connections. Order HP part number 08902-60027.

High-Stability, Internal-Reference Retrofit Kit (Option 002) This kit contains all the necessary components and full instructions for installation of the high-stability, internal-reference oscillator. Order HP part number 08902-60281.

Rear-Panel Local Oscillator Connections Retrofit Kit (Option 003) This kit contains all the necessary components and full instructions for installation of rear-panel local oscillator connections. Order HP part number 08901-60280. (These connections are already included in all Option 030 Series instruments.)

Conversion to 400 Hz Line Operation Measuring Receivers not equipped to operate at line power frequencies greater than 66 Hz may be converted to operate at line frequencies from 48 to 440 Hz. However, operation at line frequencies greater than 66 Hz will be restricted to line voltages less than or equal to 126.5 Vac. To convert to 400 Hz operation, order HP part number 08902-60029. After installation, performance will be identical to the HP 8902A Option 004.

Mechanical Equipment Available

The following kits might have been ordered and received with the Measuring Receiver as options. If they were not ordered with the original shipment and are now desired, they can be ordered from the nearest Hewlett-Packard office using the appropriate part number.

Front-Handle Kit (Option 907) Ease of handling is increased with the front-panel handles. Order HP part number 5061-9690 for the basic kit and 2190-0048 for lockwashers (8 required).

Rack-Flange Kit (Option 908) The Measuring Receiver can be solidly mounted to the instrument rack using the flange kit. Order HP part number 5061-9678.

Rack-Flange and Front-Handle Combination Kit (Option 909) This is not a front-handle kit and a rack-flange kit packaged together; it is composed of a unique part which combines both functions. Order HP part number 5061-9684 for the basic kit and 2190-9609 for lockwashers (8 required).

Chassis Slide-Mount Kit This kit is extremely useful when the Measuring Receiver is rack mounted. Access to internal circuits and components or the rear panel is possible without removing the instrument from the rack. Order HP part number 1494-0017 for 432 mm (17 in.) fixed slides. (To order adapters for non-HP rack enclosures, use HP part number 1494-0023.)

Chassis-Tilt, Slide-Mount Kit This kit is the same as the Chassis Slide Mount Kit above except it also allows the tilting of the instrument up or down 90°. Order HP part number 1494-0025 for 432 mm (17 in.) tilting slides. To order adapters for non-HP rack enclosures, use HP part number 1494-0023.

1-9. DESCRIPTION OF THE MEASURING RECEIVER

The HP Model 8902A Measuring Receiver is a complete measurement system for accurately characterizing signals in the 150 kHz to 1300 MHz frequency range. It combines the capabilities of four separate instruments in its ability to measure RF power, tuned RF level, carrier frequency, modulation and the characteristics of the demodulated audio signal (as well as those of external audio signals). This flexibility allows you to make those measurements most commonly needed to totally characterize a signal.

The Measuring Receiver can measure an RF signal's frequency, frequency drift, power level (broadband, tuned, and off-channel), amplitude modulation (AM), frequency modulation (FM), phase modulation (Φ M), and AM and FM noise components. It recovers the modulating signal and can measure the audio signal's frequency and distortion.

The Measuring Receiver is fully automatic and all major measurements can be made by pushing a single key. The Measuring Receiver's large digital display shows measurement results with excellent resolution and is easy to read. All Measuring Receiver operations can be controlled and all measurement results can be transferred via the Hewlett-Packard Interface Bus (HP-IB). (HP-IB is Hewlett-Packard's implementation of IEEE Standard 488 and ANSI Standard MC1.1.)

Power Measurements

RF Power

The Measuring Receiver delivers the accuracy and resolution of a high-performance power meter. The HP 8902A, with the HP 11722A Sensor Module, measures power from +30 dBm to -20 dBm at frequencies from 100 kHz to 2.6 GHz. (Refer to Table 1-1, *Specifications*, for specified frequencies limits using other power sensors. The HP 8902A also accepts all HP 8480 series power sensors for extended measurement capability.)

Input Power Protection The Measuring Receiver is equipped with input power protection to prevent damage from the accidental application of excessive power. (This is a common cause of damage in equipment used to measure transmitters.) The Measuring Receiver is tested for inputs up to 2W. Protection is provided by limiting diodes and an RF relay. When excessive power is applied, the relay opens and protects sensitive components, and the Measuring Receiver displays an error message. The circuit automatically resets whenever a key is depressed.

RF Power Calibration RF Power Calibration is accomplished with the 50 MHz, 1 mW standard available in every instrument. Also, the front-panel ZERO function enables you to zero the sensor module without removing it from the source-under-test. After the ZERO key is pressed, the new zero offsets are stored automatically.

RF Power Calibration Factors RF Power Calibration Factors can be entered from the power sensor into the Measuring Receiver's non-volatile memory. The instrument automatically compensates for the power sensor's efficiency and mismatch loss at each frequency.

Tuned RF Level The Measuring Receiver has a minimum sensitivity of -127 dBm with exceptional accuracy. Relative-level measurements with accuracy expected only from a transfer standard can be made.

High Selectivity Measurements Options 030-037 add selective power measurement capability to the HP 8902A Measuring Receiver. Used with a low-noise external LO, the HP 8902A performs fast, accurate single-sideband (SSB) carrier noise measurements to 1.4 GHz.

RF Frequency Measurements

In automatic operation, the Measuring Receiver has the performance of a high-quality, 150 kHz to 1300 MHz frequency counter. The frequency counter automatically adjusts itself as the input level changes. There is no need to manually set or adjust the input attenuator. Because the Measuring Receiver is usually used to measure modulated signals, its frequency counter also accurately measures signals with significant levels of AM.

Modulation Measurements

The Measuring Receiver has extremely low internal noise. Incidental AM, FM, and Φ M can be measured on a wide range of simple and complex modulated signals. To complement its modulation measurement capability, the HP 8902A characterizes audio signal level, frequency, and distortion. (These features are also available for external audio signals.)

Filters, De-emphasis Networks and Modulation Calibrators

Post-Detection Audio Filters The Measuring Receiver has two high-pass and three low-pass post-detection audio filters for filtering the recovered modulation. These filters can be selected individually or in combination. Their cutoff frequencies have been chosen to match those needed for applications such as transmitter or signal generator testing. The ≈ 20 kHz filter is a Bessel filter. It minimizes overshoot for square-wave modulation so that this type of modulating waveform can also be accurately measured.

De-Emphasis Networks The Measuring Receiver contains four de-emphasis networks that can be used in addition to the audio filters. These are the ones commonly used in FM communications—25, 50, 75, and 750 μ s. When selected, the de-emphasis networks always affect the demodulated output. You can select whether the de-emphasis network affects the deviation measured. The ability to select either the actual or "de-emphasized deviation" increases the usefulness of the Measuring Receiver in many applications.

Modulation Calibrators One of the most difficult problems involved in making very accurate measurements of AM depth or FM deviation is generating a precisely modulated signal to use as a calibration standard. In all instruments, a precise AM and FM modulation standard is included.

When the output of the calibrator is connected to the Measuring Receiver's input, the amount of modulation is measured to create a calibration factor. The calibration factor can be used to automatically compensate all subsequent measurements. The calibration factor is the ratio of the measured modulation to the internally-computed modulation of the calibrator, expressed in %.

Additional Features

Tuning Features In automatic operation, the Measuring Receiver automatically tunes to the input signal and measures it.

In manual operation, you can determine the frequency to which the Measuring Receiver tunes. Entering the approximate frequency on the keyboard causes all but very close interfering signals to be eliminated. This allows the Measuring Receiver to selectively measure signals other than the largest.

A track mode feature enables you to track a signal, as it changes frequency, from either automatic or manual tune operation.

Store and Recall functions These functions enable you to store eight complete instrument settings in non-volatile memory and recall them as needed.

Display Flexibility The Measuring Receiver offers numerous data-display formats. For example, RF power and tuned RF level can be displayed in watts, dBm, V, dBV, mV, dBmV, μ V, and dB μ V. Use the RATIO and LOG/LIN keys to display results in dB or % relative to either a measured value or a value entered from the keyboard. These features eliminate the need for recalculating measurement results.

Special Functions

The Measuring Receiver can do more than is apparent from the front panel. Many functions are accessed using the numeric keys and a Special Function key. The Special Functions provide access to other measurements and functions, manual control of instrument functions, instrument operation verification, and service aids.

All instrument functions not set using these Special Functions remain in the automatic mode. This allows you to select any combination of manual or automatic operations. By depressing the special key alone, the display shows ten digits that indicate which functions are in automatic and the state of those manually set.

There are also numerous Special Functions that can be used in verifying that the instrument and its various sections are operating properly. These, along with service special functions, make diagnosing and repairing the Measuring Receiver faster and easier.

Those Special Functions that are most commonly used in operating the Measuring Receiver are described on the *Special Function Information* pull-out card under the front panel.

Extending Measurement Range

Operation to 42 GHz is accomplished when an external LO and mixer are included in the measurement path. This system then functions as a single instrument making microwave modulation, frequency, power, and level measurements. You control operation from the Measuring Receiver's front panel. When the external LO frequency must be changed, the Measuring Receiver requests an external controller to make the change. A separate, non-volatile calibration factor table is available in Frequency Offset mode for your microwave power sensor.

Programmability

The Measuring Receiver is completely programmable via the Hewlett-Packard Interface Bus (HP-IB). This, coupled with the diversity of measurements the Measuring Receiver can make, the speed with which these measurements can be made, and the flexibility of the Special Functions, make the instrument ideal for systems applications. In many instances it can reduce the number of instruments in a system, speed measurements, reduce complexity and improve accuracy.

When the Measuring Receiver is in remote, the front-panel annunciators make it very easy to determine the state the instrument is in; whether it is in the talk, listen, or service request state.

1-10. PRINCIPLES OF OPERATION USING A SIMPLIFIED BLOCK DIAGRAM

The Measuring Receiver is a calibrated, superheterodyne receiver, which converts the incoming signal to a fixed, intermediate frequency (IF), which is then demodulated. As in a radio receiver, the Measuring Receiver contains an RF amplifier, a local oscillator (LO), a mixer, an IF amplifier and bandpass filter, a demodulator (detector or discriminator), and audio filters (tone controls). The Measuring Receiver, however, contains additional features which make it much more versatile:

- automatic tuning,
- selectable measurement mode: signal frequency, power level, or modulation (AM, FM, or Phase Modulation (Φ M)),
- RF power level measurements on tuned signals to -127 dBm ($0.1 \mu\text{V}$),
- relative RF level measurements on out-of-channel signals to -129 dBc (Option Series 030),
- selectable audio detector (peak, average, or rms responding),
- audio counter,
- audio distortion analyzer,
- measurement calibrators (AM, FM, or power level), and
- HP-IB programmability.

The entire operation of the instrument is governed by a microprocessor-based Controller. The Controller sets up the instrument at turnon, interprets keyboard entries, executes changes in internal hardware, and displays measurement results and error messages. The computing capability of the Controller is also used to simplify circuit operation. For example, it forms the last stage of the Counter, calculates the AM or FM generated by the AM and FM Calibrators, and converts measurement results into ratios (in % or dB). The Controller also contains routines useful for servicing the instrument.

RF Circuitry

The RF input signal normally enters an external Sensor Module such as an HP 11722A. (See Figure 1-2.) For all measurements except RF Power, the Sensor Module routes the signal to the RF input connector of the Measuring Receiver. For the RF Power measurement, the input signal passes directly into the Power Sensor, which converts the RF power absorbed by the RF Power Sensor into a low-frequency, chopped, ac voltage whose amplitude is proportional to the average RF power. The Power Meter amplifies the chopped signal and converts it to a dc voltage which is then measured by the voltmeter. (The voltmeter includes the Audio Peak Detector, Audio Average Detector, Voltage-to-Time Converter, and Counter.) The calibration of the Power Meter can be verified by connecting the Sensor Module to the CALIBRATION RF POWER OUTPUT connector on the front panel. (The 50 MHz Power Reference Oscillator is an accurate 1 mW reference.)

CAUTION

The Power Sensor is unprotected against and is easily damaged by sudden, large overloads. Refer to Table 1-1 under RF Power, Supplemental Characteristics, RF Power Ranges of HP 8902A Measuring Receiver with HP 11722A Sensor Module, for information on maximum operating levels.

The broadband, low-noise RF Amplifier improves the sensitivity of the Tuned RF Level measurement. The amplifier is normally bypassed in the other measurement modes.

CAUTION

An RF detector in the RF Amplifier (not shown in Figure 1-2) causes the RF Amplifier to be bypassed when an overload occurs. However, because of the relatively long switching time (approximately 30 ms), the RF Amplifier can be damaged by a large overload. Refer to Table 1-1, under RF Input, Operating Level, for information on maximum operating levels.

When the RF Peak Detector senses that the input signal level exceeds 1W, it opens the Overpower Relay. This is done without intervention of the Controller. The output from the RF Peak Detector, read by the voltmeter, is used to set the Input Attenuator to optimize the level applied to the Input Mixer.

The Input Mixer converts the input signal to the intermediate frequency (IF). For frequencies greater than 10 MHz, the IF is 1.5 MHz with the Local Oscillator (LO) tuned 1.5 MHz above the input frequency; an IF of 455 kHz can be manually selected for this frequency range. The 455 kHz IF is selected automatically for input signals between 2.5 MHz and 10 MHz and for the Tuned RF Level measurement at all frequencies. Below 2.5 MHz, the input passes directly through the Input Mixer without down-conversion. (The Tuned RF Level measurement is invalid below 2.5 MHz.)

NOTE

For the input signal to pass through the Input Mixer without down-conversion, the LO must still be present to turn the mixer diodes on. An LO frequency of 101.5 MHz is arbitrarily used. Thus the instrument will respond to input frequencies of 100 or 103 MHz as well as frequencies between 150 kHz and 2.5 MHz.

The instrument can be manually tuned to a desired signal even in the presence of larger signals, although filtering may be necessary since low-frequency signals pass directly into the IF. The RF High-Pass Filter can be inserted (via a Special Function) in the RF path for this purpose.

To measure the input frequency, the Counter measures the frequency of the LO and the frequency of the IF from the output of the IF Amplifier and Filter. The Controller computes and displays the difference between the two frequencies. For input frequencies below 2.5 MHz, only the IF is counted, which equals the input frequency.

LO Circuitry

The LO drives the high-level port of the Input Mixer and is one of several inputs to the Counter. The LO has four main modes of operation:

- tuning to the frequency required to down-convert a signal whose frequency is entered from the keyboard (manual tune mode),
- automatically searching for an input signal, then tuning the LO to the frequency required to down-convert the signal (automatic tune mode),

- automatically searching for an input signal, then configuring the LO in a feedback loop that automatically tracks the signal (automatic tune track mode), and
- tuning to the frequency required to down-convert a signal whose frequency is entered from the keyboard, then configuring the LO in a feedback loop that automatically tracks the input signal (manual tune track mode).

The manual tune track mode is useful when it is desired to follow an unstable signal in the presence of other signals. The non-track modes are used when the LO noise (residual FM) must be minimized.

IF Circuitry

The gain of the IF Amplifier is fixed except for the Tuned RF Level measurement mode (described below). The IF Filters determine the frequency response of the IF. The IF Filters can be manually selected with Special Function 3 as described in the following table. When the 1.5 MHz IF is selected, the IF filter consists of a 150 kHz to 2.5 MHz bandpass filter (with a nominal center frequency of 1.5 MHz). When the 455 kHz IF is selected, the IF filter is the Wide 455 kHz Bandpass Filter (with a bandwidth of 200 kHz) except for the Tuned RF Level measurement mode where the Narrow 455 kHz Bandpass (with a bandwidth of 30 kHz) is also inserted. (Other exceptions are noted in the following table.)

Frequency Range	Special Function	
	Tuned RF Level	All Others
10 to 1300 MHz	3.6	3.2
2.5 to 10 MHz	3.5	3.1
150 kHz to 2.5 MHz	-	3.2

In the Tuned RF Level measurement mode, the signal (after amplification by IF Amplifier, which is now a precision, variable-gain amplifier) is detected by the IF Synchronous Detector, which phase locks to and tracks the IF signal. The narrow bandwidth of the phase lock loop (150 Hz) makes it possible for the detector to measure the signal level even when the signal is buried in noise.

To enhance the accuracy of this low-level measurement, the operator must first provide a high-level signal at the desired frequency. (The range of acceptable levels depends on the type of Power Sensor used.) The level is measured by both the Power Meter (which is assumed to be the calibration standard) and the IF Synchronous Detector. From the two power measurements, the Controller computes a calibration factor, which corrects subsequent level measurements made at the same frequency.

Another way of making a tuned RF level measurement is with the IF Average Detector (accessed with Special Function 4), which is part of the AM Demodulator. (Refer to *Tuned RF Level* in the *Detailed Operating Instructions* of Section 3 in this *Operating Information* manual.) Although somewhat less sensitive than the IF Synchronous Detector, the IF Average Detector has a wider bandwidth, which gives it the ability to make measurements on signals with higher residual FM.

In instruments with Option Series 030, the IF signal is further processed by the Channel Filters (which also includes a precision, variable-gain amplifier) and detected by the IF RMS Detector. The Channel Filters set the IF bandwidth and gain for the Adjacent Channel measurement. The measurement is made by entering a series of Special Functions which establish an IF reference in the center of the Channel Filter, then allow the relative IF level to be displayed as the IF frequency is detuned by a pre-determined offset.

Audio Circuitry

The modulation on the IF is demodulated by either the AM or the FM Demodulator. Phase modulation is recovered by integrating the demodulated FM in the Audio Filters and Gain Control circuitry.

The demodulated signal is amplified and filtered in the Audio Filters and Gain Control circuitry. The filters are selected from the front panel, and for FM, the filtering may also include de-emphasis. The processed signal is passed to the front-panel MODULATION OUTPUT/AUDIO INPUT connector and the voltmeter.

The audio signal from the Audio Filters and Gain Control is converted to a dc voltage by the Audio Peak Detector, the Audio Average Detector or the Audio RMS detector. The Audio Average and RMS Detectors are used primarily for measuring noise. The output from the detectors is routed into the Voltage-to-Time Converter.

The Voltage-to-Time Converter within the voltmeter converts the dc input into a time interval. During the interval, the 10 MHz Time Base Reference is counted by the Counter, and the resultant count represents the dc voltage. Other inputs to the voltmeter, which are not shown, include outputs from an audio level detector and the AM calibrator.

The Distortion Analyzer measures the distortion of either the internal demodulated signal or an audio signal applied externally to the MODULATION OUTPUT/AUDIO INPUT connector. The frequency of the input signal must be either 1 kHz or 400 Hz. The distortion on the signal is determined by measuring the amplitude of the signal before and after a notch filter that is set to 1 kHz or 400 Hz. The two ac signals are converted to dc by the Audio RMS Detector and then measured by the voltmeter. Distortion is computed as the ratio of the voltage out of the notch filter to the voltage into the filter. (The Audio RMS Detector can also be used to measure the demodulated AM, FM, or Φ M internally or the ac level of an external audio signal applied to the MODULATION OUTPUT/AUDIO INPUT connector.)

The frequency of the audio signal at the MODULATION OUTPUT/AUDIO INPUT connector, whether internal or external, is measured by a reciprocal-type Audio Counter. In the Audio Counter, the input signal is used to gate the 10 MHz Time Base Reference into the main Counter. (This gating function is also used by the Voltage-to-Time Converter.) The number of time base pulses received during the count is read by the Controller which computes and displays the signal frequency.

The AM and FM Calibrators provide a nominal 10.1 MHz signal with a precisely known amount of AM or FM. When this signal is applied to the instrument's RF INPUT connector (either directly or via the Sensor Module), the modulation is measured and the calibration factor of the AM or FM Demodulator is computed and displayed. Related front-panel functions are automatically set for proper demodulation of the calibrator signal.

1-11. MODULATION BASICS

The Measuring Receiver can demodulate and measure three types of modulation: amplitude modulation (AM), frequency modulation (FM), and phase modulation (Φ M). In general, modulation is that characteristic of a signal which conveys the information. A signal without modulation is said to be a continuous-wave (CW) signal. CW signals contain two information-carrying parameters: amplitude and frequency. These two parameters, however, are static (time invariant). Consequently, the information conveyed by them is scant—you know only that a signal is present at a certain frequency. When one or both of these parameters is altered as a function of time, the signal is said to be modulated.

The RF signal which is modulated is called the carrier. The modulating signal is referred to as the baseband signal and can be of any arbitrary form (for example, voice, tone, noise). Demodulation is the process of recovering the baseband signal from the modulated carrier. The Measuring Receiver can measure the modulation on carriers in the range of 150 kHz to 1300 MHz. Measurement accuracy is specified for modulation rates generally between 20 Hz and 100 kHz. The demodulated signal is present at the MODULATION OUTPUT connector.

Amplitude Modulation

As the name implies, a carrier is amplitude modulated when its amplitude is varied as a function

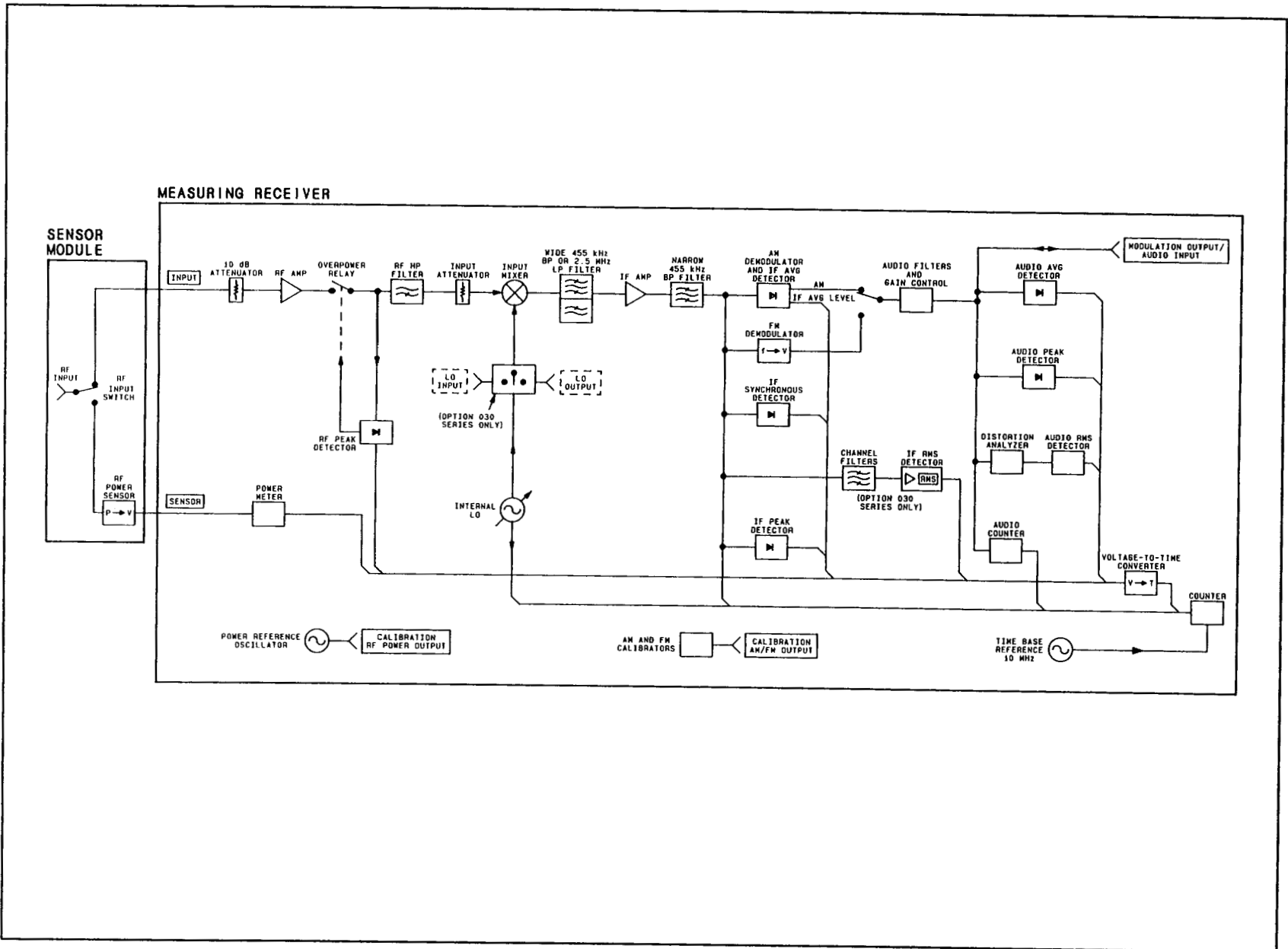

Figure 1-2. HP 8902A Measuring Receiver Simplified Block Diagram

of time. Figure 1-3 shows a carrier with amplitude modulation and, for reference, also shows the baseband signal. As you can see, the tips of the carrier trace out a waveform that resembles the baseband signal. This trace is called the envelope. The envelope rises to a maximum called the peak and drops to a minimum called the trough.

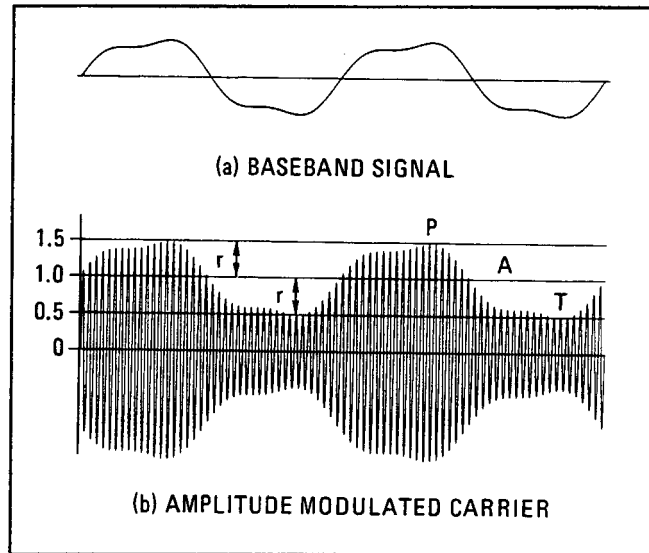

Figure 1-3. *A Baseband Signal and the Corresponding Amplitude Modulated Carrier*

A quantity which describes the amount of AM or the AM depth is the modulation index. If the peak amplitude is called P and the trough amplitude is called T , the modulation index m (usually expressed in %) is defined as

$$m = \frac{P - T}{P + T} \times 100\%.$$

In the example of Figure 1-3, $P = 1.5$ and $T = 0.5$; therefore,

$$m = \frac{1.5 - 0.5}{1.5 + 0.5} \times 100\% = 50\%.$$

Figure 1-4 shows AM signals with modulation indexes varying from 0 to 100%.

When the baseband signal is symmetrical, the modulation index can also be expressed in terms of the average carrier level, A , and the envelope peak, r , relative to the carrier. Then $P = A + r$, and $T = A - r$, and the expression for modulation index becomes

$$m = \frac{A + r - A + r}{A + r + A - r} \times 100\% = \frac{2r}{2A} \times 100\% = \frac{r}{A} \times 100\%.$$

This is the expression which the Measuring Receiver evaluates when making an AM measurement. Referring back to Figure 1-3, it is apparent that $A = 1$ and $r = 0.5$ so

$$m = \frac{0.5}{1} \times 100\% = 50\%$$

as before.

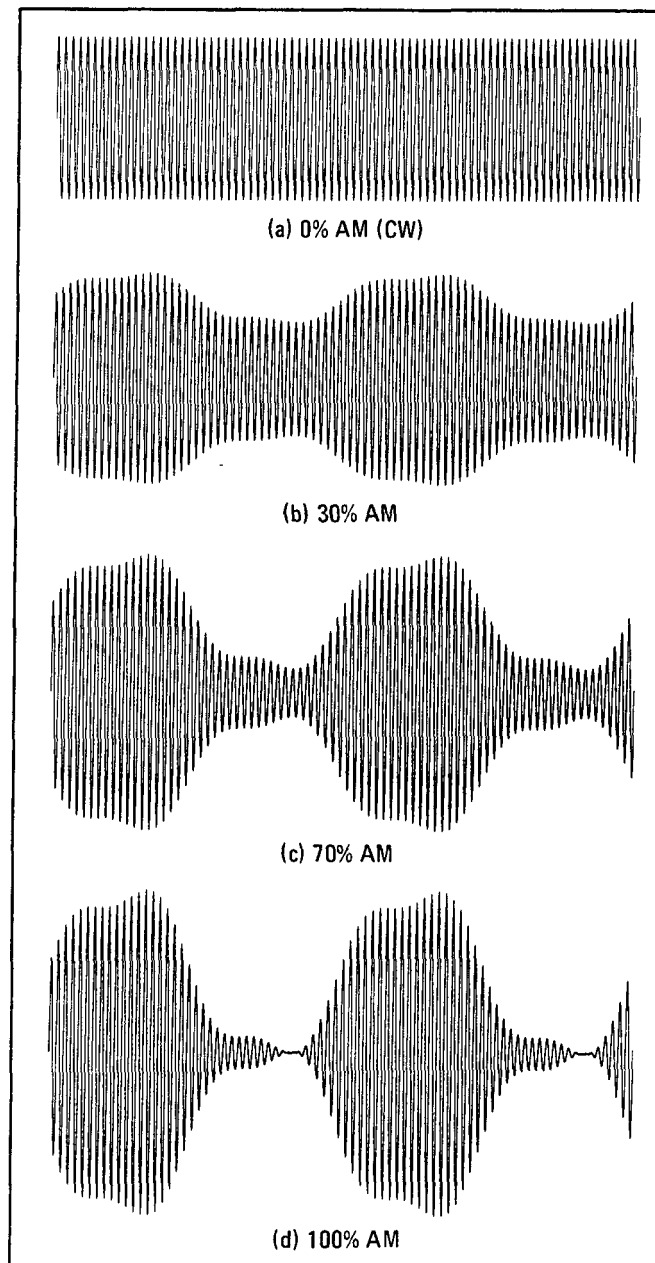

Figure 1-4. AM for Various Depths

The Measuring Receiver makes an AM measurement by forcing the average carrier level, A , to a known, fixed level by means of an automatic level control (ALC) circuit. The signal is then demodulated, and the amplitude of the recovered baseband signal is measured with a peak detector. The output of the detector is r , which is (in effect) multiplied by the constant $100/A$ and displayed as the % AM.

Figure 1-5 illustrates an AM signal with an asymmetrical baseband source. The first definition of modulation index still applies here. For it, $m = 46\%$. The second definition, however, does not apply since $P - A \neq A - T$. The Measuring Receiver detects a different value for r if the positive peak of the recovered signal is detected than if the negative peak is detected. Thus a different modulation index is measured in PEAK+ than PEAK-.

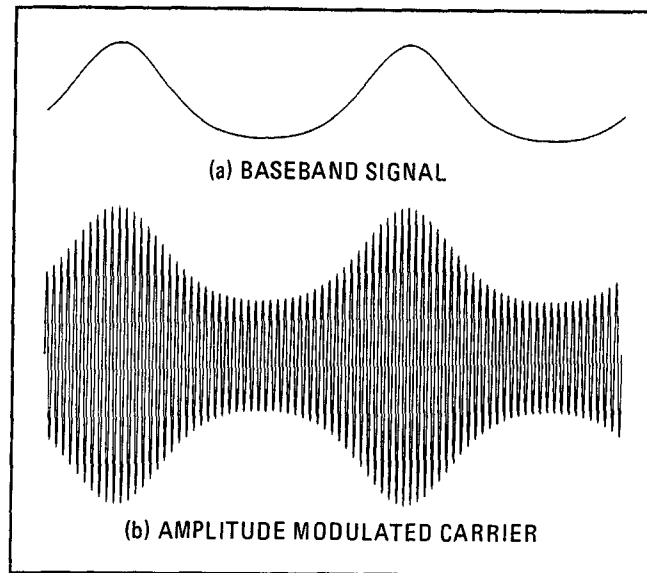

Figure 1-5. AM with an Asymmetrical Baseband Signal

The range of modulation indexes for AM measurements by the Measuring Receiver is essentially 0 to 100%. There are, however, types of modulation that produce modulation indexes greater than 100%. An example of such is suppressed-carrier AM. The Measuring Receiver is not intended for measuring such signals. Nevertheless, there are cases, when the Measuring Receiver will display a modulation index that exceeds 100%. This can occur, for example, on an asymmetrical waveform where a narrow peak is greater than the average carrier level. This is illustrated in Figure 1-6.

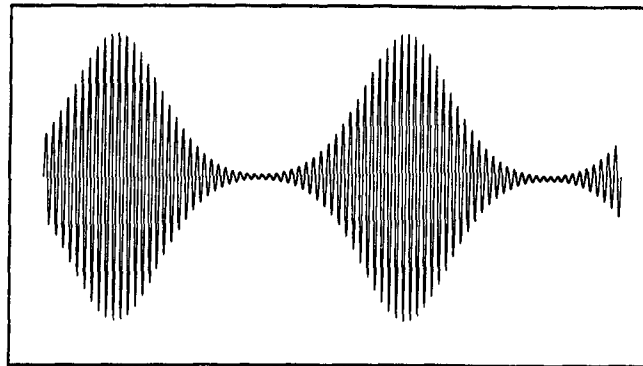

Figure 1-6. AM with Modulation Exceeding 100% as Measured by the PEAK+ Detector

Exponential Modulation

Exponential (or angular) modulation is the generic name given to modulation in which the frequency or phase of the carrier is varied. Frequency and phase modulation are very closely related. In fact, it is impossible to tell whether the signal was produced by a frequency modulator or phase modulator by analyzing the received signal unless specific information about the baseband signal is given.

It is certainly true to say that a signal is frequency modulated when the modulation is generated by a frequency modulator. A varactor diode across the tank circuit of an LC oscillator will produce FM when the varactor bias is varied. It is also true that a signal is phase modulated when the modulation is generated by a phase modulator. A varactor diode across an RF filter will produce Φ M when the varactor bias is varied. (It is assumed that the carrier is on the slope of the filter and that the filter is

driven from a well-buffered carrier source. This modulator simultaneously produces AM.)

The signal from both modulators will show readings on the Measuring Receiver when in both the FM and Φ M measurement modes. When in FM, the quantity being measured is the peak frequency deviation, which is the maximum frequency excursion from the average carrier frequency. When measuring Φ M, the peak phase deviation is measured, which is the maximum phase excursion from the average carrier phase. Phase and frequency have the relationship that phase is the integral of the frequency or frequency is the derivative of the phase. In fact, the Measuring Receiver demodulates Φ M by integrating the demodulated FM.

This relationship is most easily visualized by some examples. Look at Figure 1-7. The first baseband signal shown is a square wave. The three waveforms under it are the result of applying this signal to an FM, Φ M, and AM modulator respectively. (The AM waveform is included only for reference.) It is assumed that the phase modulator doesn't produce AM—only Φ M. The FM waveform is as expected. The frequency goes up on the positive peak of the baseband signal and down on the negative peak. The phase modulated signal, however, is peculiar. The frequency is generally constant throughout except for a discontinuity where the baseband signal switches amplitude. The waveform of the figure was contrived so that a 180° phase shift occurred exactly at a zero crossing of the carrier. In general, a discontinuity will occur when the baseband signal switches amplitude, but the phase shift is not necessarily 180° and does not need to occur at a zero crossing of the carrier. Mathematically, the derivative of a square wave is the constant zero except for a positive spike (impulse) where the baseband signal switches positive and a negative spike where the square wave switches negative.

Now look at the triangle wave. The frequency modulator produces a continually increasing frequency as the baseband signal slopes upward and a continually decreasing frequency as the signal slopes downward. The phase modulator produces a signal that resembles the signal from the frequency modulator for the square wave baseband signal. This is because the derivative of a constant slope is a constant. When the slope is positive, the phase shift is continually increasing, thus producing a uniform frequency shift upward. When the slope is negative, the phase shift is continually decreasing and produces a downward frequency shift. For the triangle wave baseband signal, the shift in frequency when the slope changes is proportional to the change in slope.

Now note the sine wave of Figure 1-7(c). The signals from the frequency and phase modulators look the same except for the 90° phase shift between the two. For the frequency modulated signal, the frequency is highest when the baseband signal is most positive and lowest when most negative. For the phase modulated signal, the frequency is highest when the slope of the baseband signal is steepest in a positive direction. This occurs at the positive-going zero crossing. Similarly, the frequency is lowest when the slope is most negative.

If in the last example, the rate, but not the amplitude, of the baseband signal is increased, the highest and lowest frequencies of the signal from the frequency modulator stay the same—they just occur more often. However, for the signal from the phase modulator, not only do the frequency peaks occur more often, but the excursions are large because the slopes of the baseband signal are steeper at the zero crossings. See Figure 1-7(d).

The maximum frequency deviation which can be measured is 400 kHz. The maximum phase deviation is 400 rad or 400 kHz divided by the modulation rate, whichever is smaller. As with AM, an asymmetrical baseband waveform will result in different readings in PEAK+ than PEAK-.

Other Considerations

In practice, it is difficult to produce an FM or Φ M signal which does not also have a small amount of AM—called incidental AM or AM-on-FM. Likewise, an AM signal usually contains a small amount of incidental FM and Φ M. In order to accurately measure this incidental modulation, the Measuring Receiver itself must not contribute to it. This contribution is specified as AM rejection and FM rejection.

A typical CW signal also contains a small amount of residual AM, FM, and Φ M. The residual

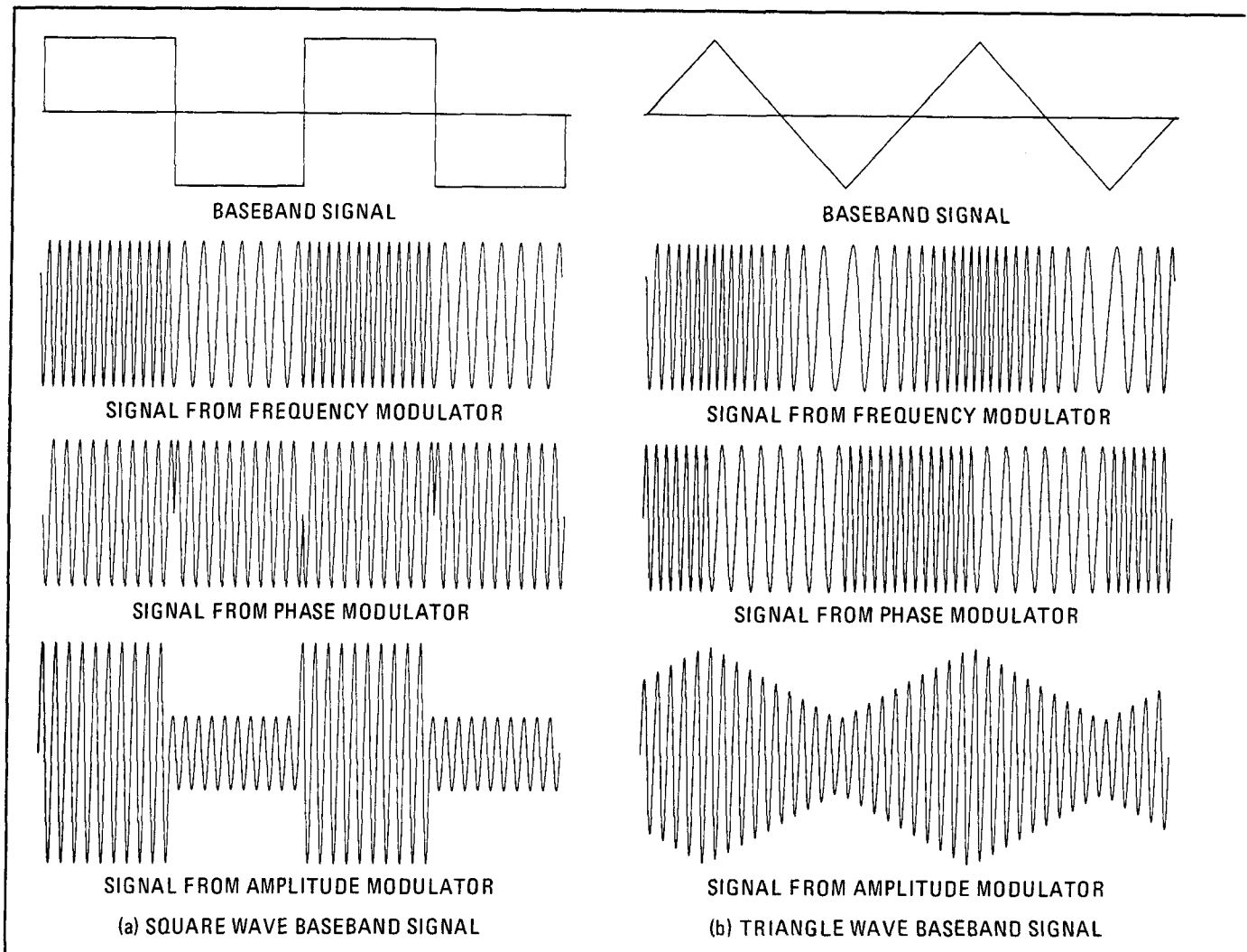
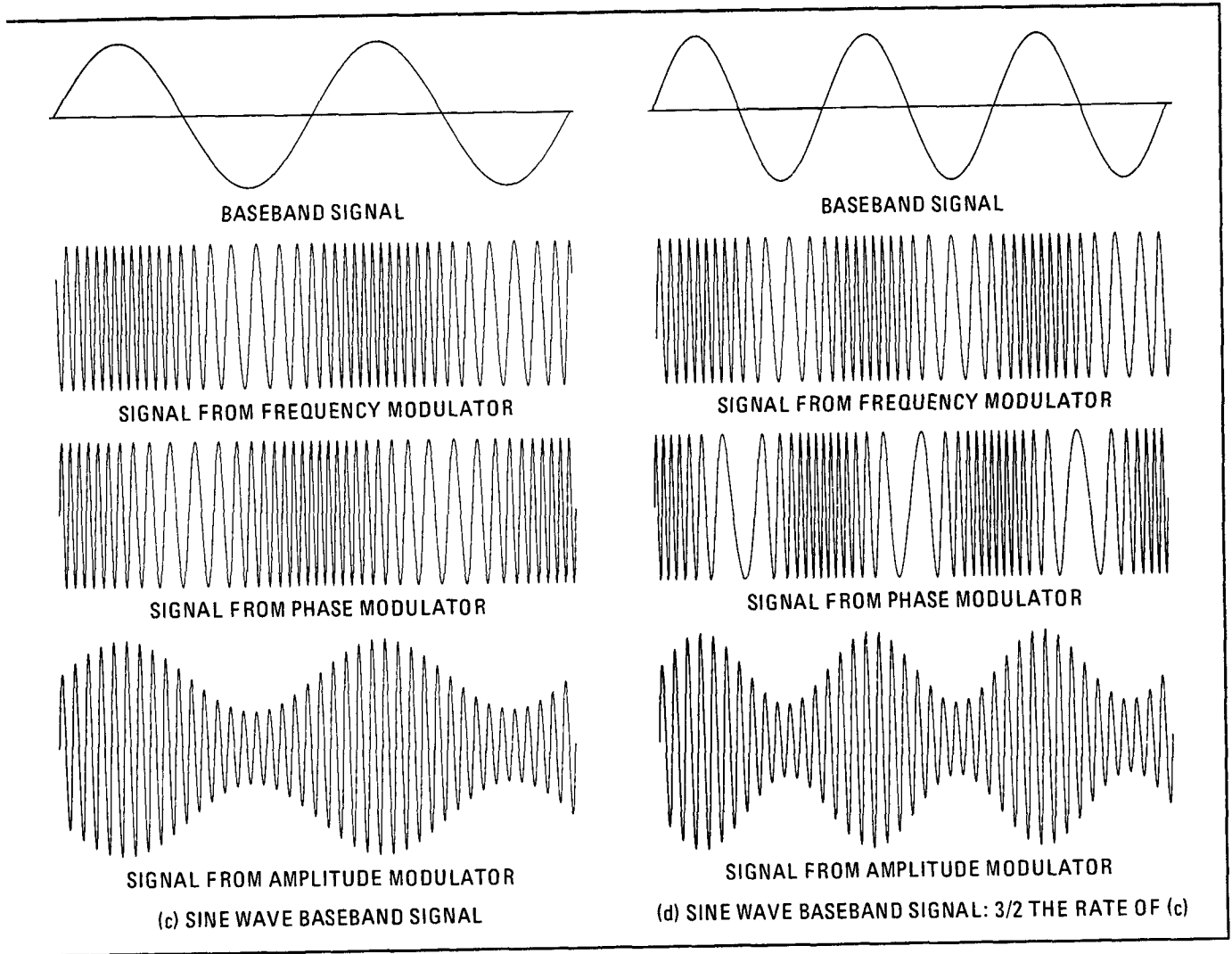

Figure 1-7. Signals from Frequency, Phase, and

modulation is generated by such things as line hum, noise, and microphonics. The residual AM and FM specifications quantify the residual modulation internal to the Measuring Receiver.

Residual modulation affects the modulation readings in a manner which depends on the detector used, the nature of the residuals, and the signal-to-noise ratio. If the residual is predominately noise, when the peak detector is used, the residuals add in a way that is statistically related to the signal-to-noise ratio. This is discussed under *Residual Noise Effects* in the *Detailed Operating Instructions* in Section 3. When the average detector is used, the residuals add approximately in an rms manner, that is, the square root of the sum of the squares of the noise and the signal. The effect of this noise becomes insignificant, however, when the signal-to-noise ratio rises above a few dB. Noise can be further reduced by filtering the demodulated signal.

In FM broadcasting and communications, the signal-to-noise ratio is improved by giving the baseband signal a high-frequency boost before applying it to the modulator. This is called pre-emphasis. The boost is a simple 6 dB per octave with the 3 dB corner specified by a time constant; for example, 75 μ s (which corresponds to a 3 dB corner of 2.12 kHz) for commercial broadcast FM. If desired, the demodulated FM can be de-emphasized to equalize the signal at the modulation output and at the display.



Amplitude Modulators for Various Baseband Signals

Table 1-1. Specifications (1 of 7)

SPECIFICATIONS describe the instrument's warranted performance.
SUPPLEMENTAL CHARACTERISTICS (shown in *italics*) are intended to provide information useful in applying the instrument by giving typical, but non-warranted performance parameters.

Frequency Modulation

RATES⁶:

20 Hz to 10 kHz, 150 kHz $\leq f_c < 10$ MHz.
 20 Hz to 200 kHz, 10 MHz $\leq f_c \leq 1300$ MHz.

DEVIATIONS⁶:

40 kHz_{peak} maximum, 150 kHz $\leq f_c < 10$ MHz.
 400 kHz_{peak} maximum, 10 MHz $\leq f_c \leq 1300$ MHz.

ACCURACY^{1,2,6}:

FM Accuracy	Frequency Range	Rates	Deviations
$\pm 2\%$ of reading ± 1 digit	250 kHz-10 MHz	20 Hz-10 kHz	≤ 40 kHz _{peak}
$\pm 1\%$ of reading ± 1 digit	10 MHz-1300 MHz	50 Hz-100 kHz	≤ 400 kHz _{peak}
$\pm 5\%$ of reading ± 1 digit	10 MHz-1300 MHz	20 Hz-200 kHz	≤ 400 kHz _{peak}

For rms detector add $\pm 3\%$ of reading.

DEMODULATED OUTPUT DISTORTION^{6,7}:

THD	Frequency Range	Rates	Deviations
$< 0.1\%$	400 kHz-10 MHz	20 Hz-10 kHz	< 10 kHz
$< 0.1\%$	10 MHz-1300 MHz	20 Hz-100 kHz	< 100 kHz

AM REJECTION (50 Hz to 3 kHz BW)²:

AM Rejection	Frequency Range	Rates	AM Depths
< 20 Hz peak deviation	150 kHz-1300 MHz	400 Hz or 1 kHz	$\leq 50\%$

RESIDUAL FM (50 Hz to 3 kHz BW): < 8 Hz_{rms} at 1300 MHz, decreasing linearly with frequency to < 1 Hz_{rms} for 100 MHz and below.

Supplemental Characteristics:

MAXIMUM FM DEVIATION, RESOLUTION, AND MAXIMUM DEMODULATED OUTPUT SENSITIVITY ACROSS AN OPEN CIRCUIT (600 Ω output impedance)⁵:

Maximum Resolution	Maximum Demodulated Output Sensitivity	Deviations (ΔF)
100 Hz	0.01 mV/Hz	$\Delta F_{peak} \geq 40$ kHz
10 Hz	0.1 mV/Hz	4.0 kHz $\leq \Delta F_{peak} < 40$ kHz
1 Hz	1.0 mV/Hz	$\Delta F_{peak} < 4$ kHz
0.1 Hz (rms detector only)	1.0 mV/Hz	$\Delta F_{rms} < 0.3$ kHz

Resolution is increased one digit with 750 μ s de-emphasis and pre-display on.

The demodulated output signal present at the Modulation Out/Audio In connector is increased in amplitude by a factor of 10 with 750 μ s de-emphasis.

DEMODULATED OUTPUT DISTORTION⁷:

THD	Frequency Range	Rates	Deviations
$< 0.3\%$	150 kHz-400 kHz	20 Hz-10 kHz	< 10 kHz

DETECTORS: +peak, -peak, $\pm peak/2$, peak hold, average (rms sinewave calibrated), rms.

STEREO SEPARATION (50 Hz to 15 kHz): > 47 dB.

Amplitude Modulation

RATES:

20 Hz to 10 kHz, 150 kHz $\leq f_c < 10$ MHz.
 20 Hz to 100 kHz, 10 MHz $\leq f_c \leq 1300$ MHz.

DEPTH: to 99%.

ACCURACY^{1,2,3}:

AM Accuracy	Frequency Range	Rates	Depths
$\pm 2\%$ of reading ± 1 digit	150 kHz-10 MHz	50 Hz-10 kHz	5%-99%
$\pm 3\%$ of reading ± 1 digit	150 kHz-10 MHz	20 Hz-10 kHz	to 99%
$\pm 1\%$ of reading ± 1 digit	10 MHz-1300 MHz	50 Hz-50 kHz	5%-99%
$\pm 3\%$ of reading ± 1 digit	10 MHz-1300 MHz	20 Hz-100 kHz	to 99%

For rms detector add $\pm 3\%$ of reading.

FLATNESS^{4,5}:

Flatness	Frequency Range	Rates	Depths
$\pm 0.3\%$ of reading ± 1 digit	10 MHz-1300 MHz	90 Hz-10 kHz	20%-80%

DEMODULATED OUTPUT DISTORTION:

$< 0.3\%$ THD for $\leq 50\%$ depth.
 $< 0.6\%$ THD for $\leq 95\%$ depth.

FM REJECTION (50 Hz to 3 kHz BW)²:

FM Rejection	Frequency Range	Rates	FM Deviations
$< 0.2\%$ AM	250 kHz-10 MHz	400 Hz or 1 kHz	< 5 kHz _{peak}
$< 0.2\%$ AM	10 MHz-1300 MHz	400 Hz or 1 kHz	< 50 kHz _{peak}

RESIDUAL AM (50 Hz to 3 kHz BW): $< 0.01\%$ _{rms}.

¹ Not to exceed for stated accuracy: 50 Hz to 40 kHz rates with rms detector.

² Peak residuals must be accounted for in peak readings.

³ For peak measurements only: AM accuracy may be affected by distortion generated by the measuring receiver. In the worst case this distortion can decrease accuracy by 0.1% of reading for each 0.1% of distortion.

⁴ Flatness is the variation in indicated AM depth for constant depth on input signal.

⁵ For optimum flatness, cables should be terminated with their characteristic impedance.

⁶ But not to exceed: 20 kHz rates and 40 kHz peak deviations with 750 μ s de-emphasis filter.

⁷ With 750 μ s de-emphasis and pre-display "off," distortion is not specified for modulation outputs > 4 V peak. This condition can occur near maximum deviation for a measurement range, at rates < 2 kHz.

Table 1-1. Specifications (2 of 7)

Amplitude Modulation, continued

Supplemental Characteristics:

DETECTORS: +peak, -peak, ±peak/2, peak hold, average (rms sinewave calibrated), rms.

MAXIMUM DEPTH, RESOLUTION, AND MAXIMUM DEMODULATED OUTPUT SENSITIVITY ACROSS AN OPEN CIRCUIT (600Ω output impedance)⁵:

Maximum Resolution	Maximum Demodulated Output Sensitivity	Depths
0.1%	0.01 V/percent	AM _{peak} ≥ 40.0%
0.01%	0.1 V/percent	AM _{peak} < 40.0%
0.001% (rms detector only)	0.1 V/percent	AM _{rms} < 3.0%

Phase Modulation

RATES:

200 Hz to 10 kHz, 150 kHz ≤ f_c < 10 MHz.
200 Hz to 20 kHz, 10 MHz ≤ f_c ≤ 1300 MHz.

ACCURACY²:

±4% of reading ± 1 digit, 150 kHz ≤ f_c < 10 MHz.
±3% of reading ± 1 digit, 10 MHz ≤ f_c ≤ 1300 MHz.
For rms detector add ±3% of reading.

DEMOMULATED OUTPUT DISTORTION: < 0.1% THD.

AM REJECTION (for 50% AM at 1 kHz rate)²:
< 0.03 radians peak (50 Hz to 3 kHz BW).

MAXIMUM DEVIATION, RESOLUTION, AND MAXIMUM DEMODULATED OUTPUT SENSITIVITY ACROSS AN OPEN CIRCUIT (600Ω output impedance)⁵:

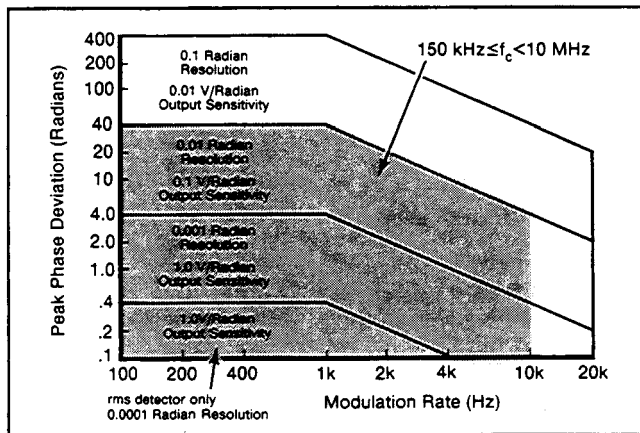

Supplemental Characteristics:

MODULATION RATES: usable from 20 Hz to 100 kHz with degraded performance.

DETECTORS: +peak, -peak, ±peak/2, peak hold, average (rms sinewave calibrated), rms.

² Peak residuals must be accounted for in peak readings.
⁵ For optimum flatness, cables should be terminated with their characteristic impedance.
⁸ After 30-day warm-up.

Modulation Reference

AM CALIBRATOR DEPTH AND ACCURACY: 33.33% depth nominal, internally calibrated to an accuracy of ±0.1%.

FM CALIBRATOR DEVIATION AND ACCURACY: 34 kHz_{peak} deviation nominal, internally calibrated to an accuracy of ±0.1%.

Supplemental Characteristics:

CARRIER FREQUENCY: 10.1 MHz.

MODULATION RATE: 10 kHz.

OUTPUT LEVEL: -25 dBm.

Frequency Counter

RANGE: 150 kHz to 1300 MHz.

SENSITIVITY:

12 mV_{rms} (-25 dBm), 150 kHz ≤ f_c ≤ 650 MHz.
22 mV_{rms} (-20 dBm), 650 MHz < f_c ≤ 1300 MHz.

MAXIMUM RESOLUTION: 1 Hz.

ACCURACY:

±reference accuracy ± 3 counts of least-significant digit, f_c < 100 MHz.
±reference accuracy ± 3 counts of least-significant digit or 30 Hz, whichever is larger, f_c ≥ 100 MHz.

Supplemental Characteristics:

Modes: Frequency and Frequency Error (displays the difference between the frequency entered via the keyboard and the actual RF input frequency).

SENSITIVITY IN MANUAL TUNING MODE:

Approximate frequency must be entered from keyboard. 0.22 mV_{rms} (-60 dBm).

Using the RF amplifier and the IF amplifiers, sensitivity can be increased to approximately -100 dBm.

Internal Time Base Reference

FREQUENCY: 10 MHz.

AGING RATE: < 1 × 10⁻⁶/month.
< 1 × 10⁻⁹/day (Option 002)⁸.

Supplemental Characteristics:

INTERNAL REFERENCE ACCURACY: Overall accuracy is a function of time base calibration, aging rate, temperature effects, line voltage effects and short-term stability.

	Standard	Option 002
Aging Rate	< 1 × 10 ⁻⁶ /mo.	< 1 × 10 ⁻⁹ /day
Temperature Effects	< 2 × 10 ⁻⁷ /°C	< 2 × 10 ⁻¹⁰ /°C
Line Voltage Effects (+5%, -10% Line Voltage Change)	< 1 × 10 ⁻⁶	< 6 × 10 ⁻¹⁰
Short-Term Stability	—	< 1 × 10 ⁻⁹ for 1 sec. average

Table 1-1. Specifications (3 of 7)

RF Power

The HP 8902A Measuring Receiver, with HP 11722A Sensor Module, performs RF power measurements from -20 dBm (10 μ W) to +30 dBm (1W) at frequencies from 100 kHz to 2.6 GHz. The HP 8902A can be used with the HP 11792A Sensor Module and any of the HP 8480 series Power Sensors (HP 8481A/1B/1H/2A/2B/2H/3A/4A/5A/6A) to make power measurements from -70 dBm (10 pW) to +44 dBm (25W) at frequencies from 100 kHz to 50 GHz. The HP 8480 Series Sensors also work with the HP 435A, HP 436A and HP 438A Power Meters. Unless otherwise specified, the specifications shown below refer to the HP 8902A only. A detailed explanation of how the uncertainty specifications provided below affect the absolute power measurement accuracy of the HP 8902A is provided in Application Note 64-1.

RF POWER RESOLUTION⁹:

- 0.01% of full scale in watts or volts mode.
- 0.01 dB in dBm or dB_{relative} mode.

LINEARITY (includes sensor non-linearity): RF range linearity \pm RF range-to-range change error.

RF RANGE LINEARITY (using Recorder Output)¹⁰:

- \pm 0.02 dB, RF ranges 2 through 5.
- \pm 0.03 dB, RF range 1.
- Using front-panel display add \pm 1 count of least-significant digit.

RF RANGE-TO-RANGE CHANGE ERROR (using Recorder Output): \pm 0.02 dB/RF range change from reference range. Using front-panel display add \pm 1 count of least-significant digit.

INPUT SWR: <1.15, using HP 11722A Sensor Module.

ZERO SET (digital settability of zero): \pm 0.5% \pm 1 count of full scale on lowest range. Decrease by a factor of 10 for each higher range.

Supplemental Characteristics:

ZERO DRIFT OF METER: \pm 0.03% of full scale/ $^{\circ}$ C on lowest range. Decrease by a factor of 10 for each higher range.

NOISE (at constant temperature, peak change over any 1-minute interval for the HP 11722A Sensor Module and HP 8481A/1B/1H/2A/2B/2H/3A/5A/6A Sensors):

- 0.4% of full scale on range 1 (lowest range).
- 0.13% of full scale on range 2.
- 0.013% of full scale on range 3.
- 0.0013% of full scale on range 4.
- 0.00013% of full scale on range 5.
- For HP 8484A Sensor multiply noise by 5 on all ranges.

ZERO DRIFT OF SENSORS (1 hour, at constant temperature after 24-hour warm-up):

- \pm 0.1% of full scale on lowest range for HP 11722A Sensor Module and HP 8481A/1B/1H/2A/2B/2H/3A/5A/6A Sensors.
- \pm 2.0% of full scale on lowest range for HP 8484A Sensor. Decrease by a factor of 10 for each higher range.

RF POWER RANGES OF HP 8902A MEASURING RECEIVER WITH HP 11722A SENSOR MODULE:

- 20 dBm to -10 dBm (10 μ W to 100 μ W), range 1.
- 10 dBm to 0 dBm (100 μ W to 1 mW), range 2.
- 0 dBm to +10 dBm (1 mW to 10 mW), range 3.
- +10 dBm to +20 dBm (10 mW to 100 mW), range 4.
- +20 dBm to +30 dBm (100 mW to 1W), range 5.

RESPONSE TIME (0 to 99% of reading):

- <10 seconds, range 1.
- <1 second, range 2.
- <100 milliseconds, ranges 3 through 5.

DISPLAYED UNITS: Watts, dBm, dB_{relative}, %_{relative}, volts, mV, μ V, dB V, dB mV, dB μ V.

INTERNAL NON-VOLATILE CAL FACTOR TABLES (user modifiable using special functions):

Maximum Number of Cal Factor/Frequency Entries:

Table #1 (primary): 16 pairs plus Reference Cal Factor.

Table #2 (frequency offset): 22 pairs plus Reference Cal Factor.

Maximum Allowed Frequency Entry: 200 GHz.

Frequency Entry Resolution: 50 kHz.

Cal Factor Range: 40 to 120%.

Cal Factor Resolution: 0.1%.

Power Reference

POWER OUTPUT: 1.00 mW. Factory set to \pm 0.7%, traceable to the U.S. National Bureau of Standards.

ACCURACY: \pm 1.2% worst case (\pm 0.9% rss) for one year (0 $^{\circ}$ C to 55 $^{\circ}$ C).

Supplemental Characteristics:

FREQUENCY: 50 MHz nominal.

SWR: 1.05 nominal.

FRONT PANEL CONNECTOR: Type-N female.

Tuned RF Level

POWER RANGE: -127 dBm to 0 dBm, using IF synchronous detector (200 Hz BW).
-100 dBm to 0 dBm, using IF average detector (30 kHz BW).

FREQUENCY RANGE: 2.5 MHz to 1300 MHz.

DISPLAYED RESOLUTION¹¹:

- 4 digits in watts or volts mode.
- 0.01 dB or 0.001 dB in dBm or dB_{relative} mode.

⁹ The HP 8902A fundamental RF Power measurement units are watts. Further internal processing is done on this number to display all other units.

¹⁰ When using HP 8484A Sensor the noise specification may mask the linearity specification and become the predominant error. When operating on the top RF power range, add the power sensor linearity percentages found in the power sensor specifications.

¹¹ The HP 8902A fundamental Tuned RF Level measurement units are volts. Further internal processing is done on this number to display all other units.

Table 1-1. Specifications (4 of 7)

Tuned RF Level, continued

RELATIVE MEASUREMENT ACCURACY (at constant temperature and after RF range calibration is completed)¹²: Detector linearity + IF range-to-range error + RF range-to-range error + frequency drift error + noise error ± 1 digit.

DETECTOR LINEARITY:

For IF Synchronous Detector:

- ±0.007 dB/dB change, but not more than ±0.02 dB/10 dB change.
- Typically <±0.004 dB/dB change and <±0.01 dB/10 dB change.

For IF Average Detector (0°C to +35°C):

- ±0.013 dB/dB change, but not more than ±0.04 dB/10 dB change.
- Typically <±0.008 dB/dB change and <±0.02 dB/10 dB change.

IF RANGE-TO-RANGE ERROR (see Tuned RF Level range plot)¹³:

- ±0.02 dB/IF range change, IF ranges 1 through 5.
- ±0.05 dB/IF range change, IF ranges 6 and 7.

RF RANGE-TO-RANGE ERROR:

- ±0.04 dB/RF range change (Tuned RF Level only).
- ±0.06 dB/RF range change, RF Power to Tuned RF Level.

FREQUENCY DRIFT ERROR: ±0.05 dB/kHz frequency drift from center of IF (using IF synchronous detector).

NOISE ERROR: ±0.18 dB for levels <-120 dBm, or for levels <-110 dBm if Special Function 1.9 is selected.

INPUT SWR:

- <1.18, at HP 8902A RF input, RF range 1 and 2.
- <1.40, at HP 8902A RF input, RF range 3.
- <1.33, at HP 11722A RF input, RF range 1 and 2.
- <1.50, at HP 11722A RF input, RF range 3.
- <1.33, at HP 11722A RF input, RF range 3 with Special Function 1.9.

Supplemental Characteristics:

ABSOLUTE LEVEL MEASUREMENT ACCURACY AT LOW LEVELS (at constant temperature and after RF range calibration is completed)¹²:

Absolute level measurement accuracy is a function of the RF Power and Tuned RF Level measurement accuracy. Product Note 8902A-1 explains how both of these measurements affect absolute level measurement accuracy. For a source with an output SWR of 1.7 and level of -110 dBm the typical absolute level measurement accuracy is 0.46 dB rss and 1.02 dB worst case.

IF FREQUENCY: 455 kHz.

ACQUISITION TIME: <4 seconds, ≥-110 dBm.
<10 seconds, ≥-127 dBm.

RESPONSE TIME (responding to changes in level of an acquired signal): <2 seconds, ≥-110 dBm.
<5 seconds, ≥-127 dBm.

DISPLAYED UNITS: Watts, dBm, dB_{relative}, %_{relative}, volts, mV, μV, dB V, dB mV, dB μV.

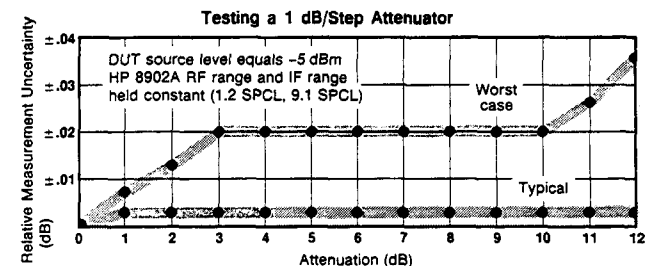
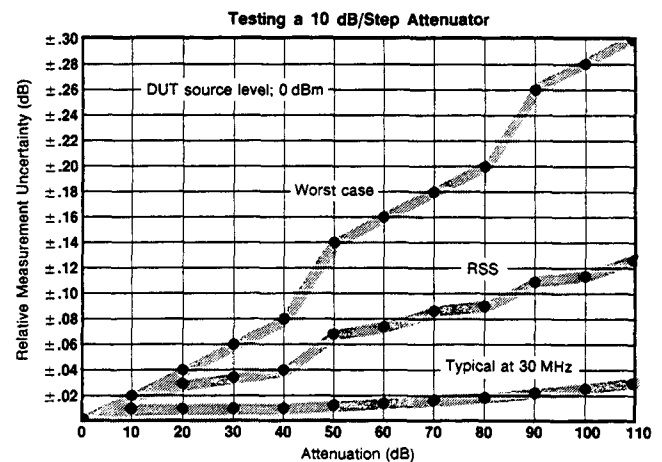
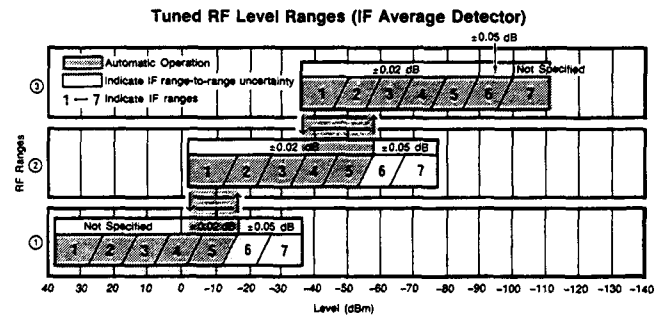
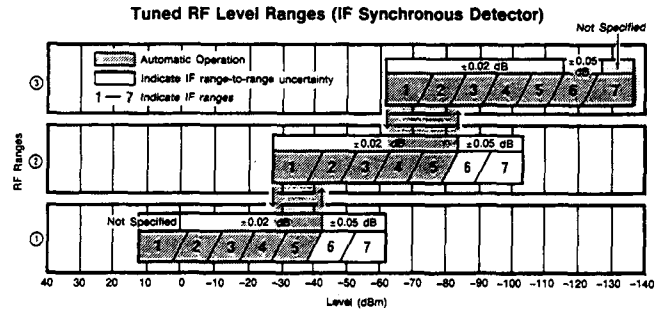

¹¹ The HP 8902A fundamental Tuned RF Level measurement units are volts. Further internal processing is done on this number to display all other units.

¹² Tuned RF Level accuracy will be affected by residual FM of the source-under-test. If the residual FM_{peak} is >50 Hz measured over a 30 second period in a 3 kHz BW, Tuned RF Level measurements should be made using the IF average detector (30 kHz BW) by using Special Function 4.4. The Tuned RF Level measurement sensitivity when using the IF average detector is -100 dBm.

¹³ IF Ranges 6 and 7 (see Tuned RF Level range plots) are only used in automatic operation for Tuned RF Level measurements below approximately -110 dBm for the IF synchronous detector, and below approximately -85 dBm for the IF average detector.

Table 1-1. Specifications (5 of 7)

Carrier Noise (Options 030-037)

FREQUENCY RANGE: 10 MHz to 1300 MHz.
CARRIER POWER RANGE: +30 dBm to -20 dBm;
 12.5 kHz, 25 kHz and 30 kHz filters.
 +30 dBm to -10 dBm; carrier noise filter.
DYNAMIC RANGE: 115 dB.
CARRIER REJECTION (temp. $\leq 35^{\circ}\text{C}$): >90 dB; for offsets of
 at least 1 channel spacing or 5 kHz, whichever is greater.
RELATIVE MEASUREMENT ACCURACY: ± 0.5 dB;
 levels ≥ -95 dBc; 12.5 kHz, 25 kHz and 30 kHz filters.
 ± 0.5 dB; levels ≥ -129 dBc/Hz; carrier noise filter.
CARRIER NOISE FILTER:
 Filter Noise Bandwidth: 2.5 kHz nominal.

**Noise Bandwidth Correction Accuracy (stored in
 non-volatile memory):** ± 0.2 dB.

Supplemental Characteristics:

ADJACENT/ALTERNATE CHANNEL FILTERS:

6 dB Filter Bandwidth:

- 8.5 kHz, 12.5 kHz adjacent-channel filter.
- 16.0 kHz, 25 kHz adjacent-channel filter.
- 30.0 kHz, 30 kHz (cellular radio) alternate-channel filter.

TYPICAL NOISE FLOOR: -150 dBc/Hz, 0 dBm carrier
 power level. For System noise performance add LO
 contribution.

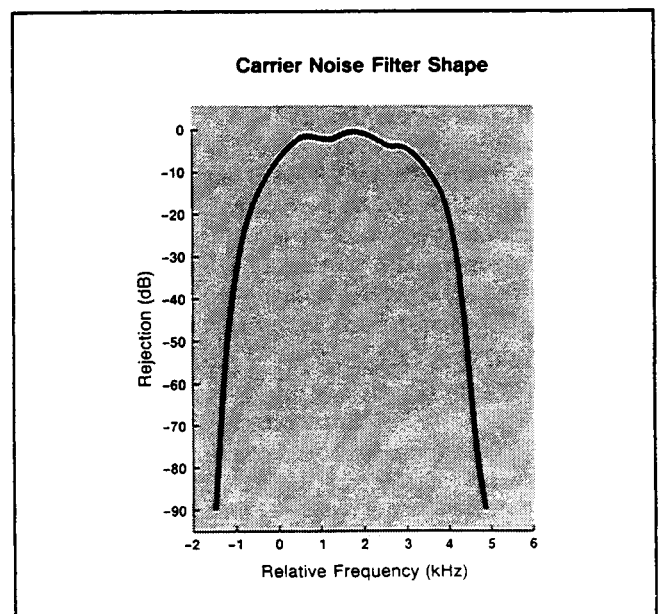
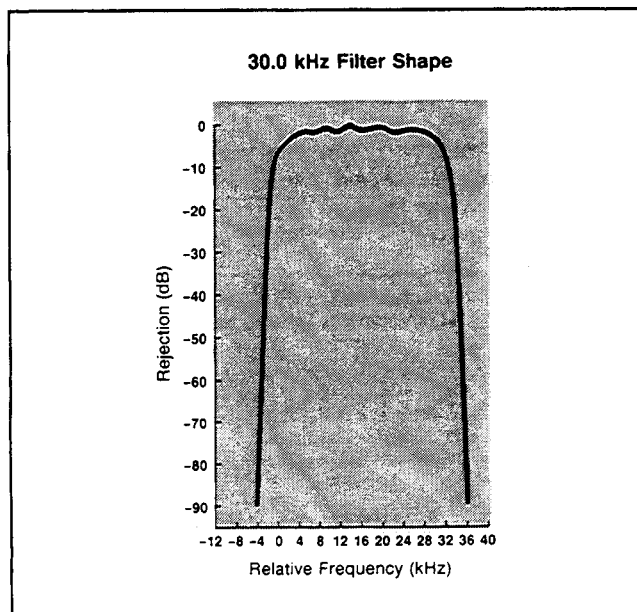
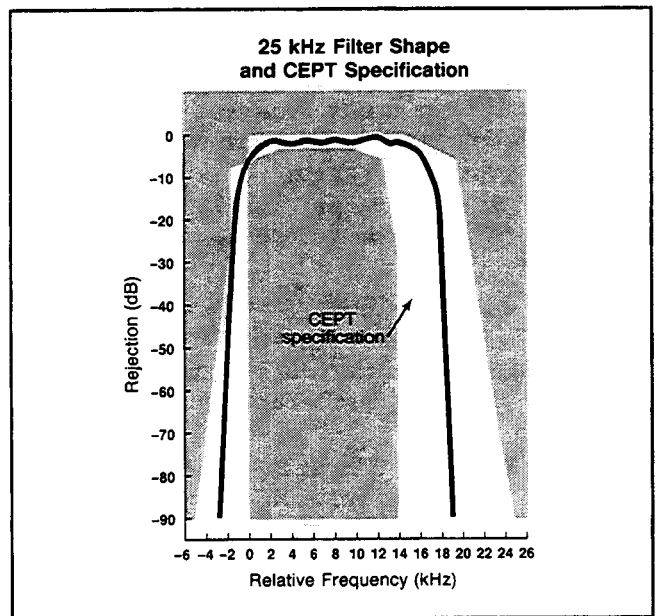
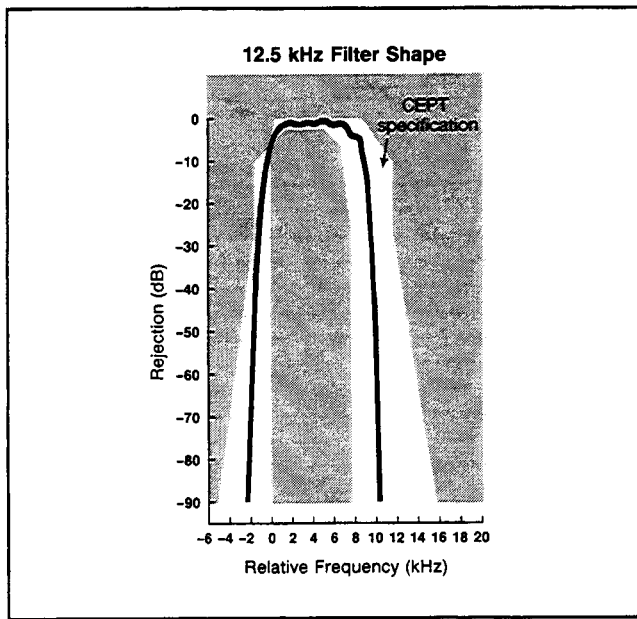

Table 1-1. Specifications

Increased Power Measurement Accuracy (Option 050)

POWER RANGE: -120 to 0 dBm

FREQUENCY RANGE: 2.5 MHz to 1300 MHz

MEASUREMENT ACCURACY^{14,15}:

Measurement	Range	Accuracy
Absolute (Using an HP 11722A Sensor Module)	0 dBm to -100 dBm	± 0.005 dB/10 dB step ± 0.120 dB ± 1 digit
	-100.001 dBm to -120.000 dBm	± 0.050 dB/10 dB step ± 0.120 dB ± 1 digit
Relative	0 dBm to -100 dBm	± 0.005 dB/10 dB step ± 0.015 dB ± 1 digit
	-100.001 dBm to -120.000 dBm	± 0.050 dB/10 dB step ± 0.015 dB ± 1 digit

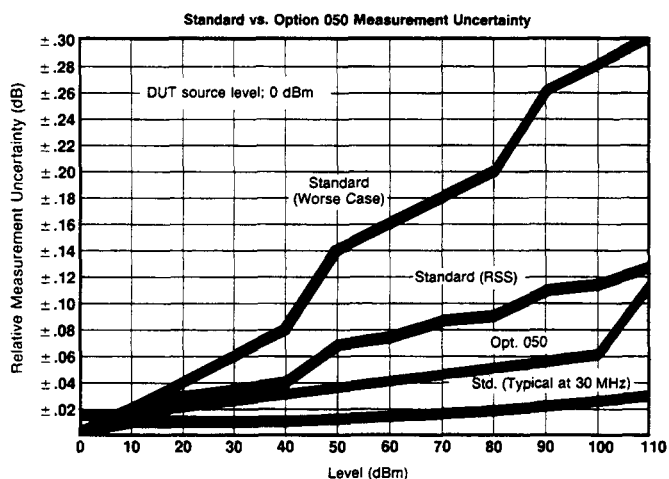

(See Tuned RF Level for other specifications.)

Supplemental Characteristics:

MEASUREMENT TIME: 10 to 30 seconds.

¹⁴ Option 050 specifications are warranted when using a Hewlett-Packard synthesized source with less than 100 Hz peak residual FM measured in a 3 kHz post-detection bandwidth over a 30 second period.

¹⁵ Accuracy specifications do not include mismatch uncertainty.

Table 1-1. Specifications (6 of 7)

Audio Frequency Counter

FREQUENCY RANGE: 20 Hz to 250 kHz (usable to 600 kHz).

MAXIMUM EXTERNAL INPUT VOLTAGE: 3V_{rms}

ACCURACY (for demodulated signals)¹⁶:

Accuracy	Frequency	Modulation (Peak)
± 3 counts of least-significant digit ± Internal Reference Accuracy	> 1 kHz	AM ≥ 10% FM ≥ 1.0 kHz φM ≥ 1.5 radians
± 0.02 Hz ± Internal Reference Accuracy	≤ 1 kHz	AM ≥ 10% FM ≥ 1.0 kHz φM ≥ 1.5 radians
± 0.2 Hz ± Internal Reference Accuracy (3 kHz low-pass filter inserted)	≤ 3 kHz	1.5% ≤ AM < 10% 0.15 kHz ≤ FM < 1.0 kHz 0.15 radian ≤ φM < 1.5 radians

ACCURACY (for external signals)¹⁶:

Accuracy	Frequency	Level
± 3 counts of least-significant digit ± Internal Reference Accuracy	> 1 kHz	≥ 100 mV _{rms}
± 0.02 Hz ± Internal Reference Accuracy	< 1 kHz	≥ 100 mV _{rms}

Supplemental Characteristics:

DISPLAYED RESOLUTION: 6 digits.

MEASUREMENT RATE: 2 readings per second.

COUNTING TECHNIQUE: Reciprocal with internal 10 MHz time base.

AUDIO INPUT IMPEDANCE: 100 kΩ nominal.

Audio RMS Level

FREQUENCY RANGE: 50 Hz to 40 kHz.

VOLTAGE RANGE: 100 mV to 3V.

ACCURACY: ± 4.0% of reading.

Supplemental Characteristics:

FULL RANGE DISPLAY: .3000V, 4.000V.

AC CONVERTER: True-rms responding for signals with crest factor of ≤ 3.

MEASUREMENT RATE: 2 readings per second.

AUDIO INPUT IMPEDANCE: 100 kΩ nominal.

Audio Distortion

FUNDAMENTAL FREQUENCIES: 400 Hz ± 5% and 1 kHz ± 5%.

MAXIMUM EXTERNAL INPUT VOLTAGE: 3V.

DISPLAY RANGE: 0.01% to 100.0% (-80.00 dB to 0.00 dB).

DISPLAYED RESOLUTION: 0.01% or 0.01 dB.

ACCURACY: ± 1 dB of reading.

SENSITIVITY:

Modulation: 0.15 kHz peak FM, 1.5% peak AM or 0.6 radian peak φM.

External: 100 mV_{rms}.

RESIDUAL NOISE AND DISTORTION¹⁷:

0.3% (-50 dB), temperature < 40°C.

Supplemental Characteristics:

MEASUREMENT 3 dB BANDWIDTH: 20 Hz to 50 kHz.

DETECTION: True rms.

MEASUREMENT RATE: 1 reading per second.

AUDIO INPUT IMPEDANCE: 100 kΩ nominal.

Audio Filters

DE-EMPHASIS FILTERS: 25 μs, 50 μs, 75 μs, and 750 μs.

De-emphasis filters are single-pole, low-pass filters with 3 dB frequencies of: 6366 Hz for 25 μs, 3183 Hz for 50 μs, 2122 Hz for 75 μs, and 212 Hz for 750 μs.

50 Hz HIGH-PASS FILTER (2 pole):

Flatness: < 1% at rates ≥ 200 Hz.

300 Hz HIGH-PASS FILTER (2 pole):

Flatness: < 1% at rates ≥ 1 kHz.

3 kHz LOW-PASS FILTER (5 pole):

Flatness: < 1% at rates ≤ 1 kHz.

15 kHz LOW-PASS FILTER (5 pole):

Flatness: < 1% at rates ≤ 10 kHz.

> 20 kHz LOW-PASS FILTER (9 pole Bessel)¹⁸:

Flatness: < 1% at rates ≤ 10 kHz.

Supplemental Characteristics:

DE-EMPHASIS FILTER TIME CONSTANT

ACCURACY: ± 3%.

HIGH-PASS AND LOW-PASS FILTER 3 dB CUTOFF

FREQUENCY ACCURACY: ± 3%.

> 20 kHz LOW PASS FILTER 3 dB CUTOFF

FREQUENCY: 100 kHz nominal.

OVERSHOOT ON SQUARE WAVE MODULATION¹⁸:

< 1%.

¹⁶ With the low-pass and high-pass audio filters used to stabilize frequency readings.

¹⁷ For demodulated signals, the residual noise generated by the HP 8902A must be accounted for in distortion measurements (i.e., residual AM, FM or φM.)

¹⁸ The > 20 kHz low-pass filter is intended for minimum overshoot with square wave modulation.

Table 1-1. Specifications (7 of 7)

RF Input

FREQUENCY RANGE: 150 kHz to 1300 MHz.

OPERATING LEVEL:

Minimum Operating Level	Maximum Operating Level	Frequency Range
12 mV _{rms} (-25 dBm)	7 V _{rms} (1W _{peak}) Source SWR <4	150 kHz-650 MHz
22 mV _{rms} (-20 dBm)	7 V _{rms} (1W _{peak}) Source SWR <4	650 MHz-1300 MHz

Supplemental Characteristics:

TUNING:

Normal Mode: Automatic and manual frequency entry.

Track Mode: Automatic and manual frequency entry, $f_c \geq 10$ MHz.

Acquisition Time (automatic operation):
~1.5 seconds.

INPUT IMPEDANCE: 50 Ω nominal.

MAXIMUM SAFE DC INPUT LEVEL: 5V.

General Specifications

TEMPERATURE: Operating: 0°C to 55°C.
Storage: -55°C to 75°C.

REMOTE OPERATION: HP-IB; all functions except the line switch are remotely controllable.

HP-IB COMPATIBILITY (defined in IEEE 488-1978):
SH1, AH1, T5, TE0, L3, LE0, SR1, RL1, PP0, DC1, DT1, C0, E1.

EMI: Conducted and radiated interference is within the requirements of VDE 0871 (Level B), and CISPR publication 11.

POWER: 100, 120, 220, or 240V (+5%, -10%); 48-66 Hz; 200 VA maximum.

WEIGHT: Net 23.6 kg. (52 lb.); Shipping 31.4 kg (69 lb).

DIMENSIONS: 190 mm. H \times 426 mm. W \times 551 mm. D (7.5" \times 16.8" \times 21.7").

HP SYSTEM II MODULE SIZE: 177.0 H \times 1 MW \times 497.8 D.

HP 8902A Rear Panel Inputs/Outputs

Supplemental Characteristics:

FM OUTPUT: 10 k Ω impedance, -9V to 6V into an open circuit; ~6V/MHz, dc coupled, 16 kHz bandwidth (one pole).

AM OUTPUT: 10 k Ω impedance, -4V to 0V into an open circuit, ~8 mV/%, dc coupled, 16 kHz bandwidth (one pole).

RECORDER OUTPUT: DC voltage proportional to the measured results, 1 k Ω impedance, 0V to 4V for each resolution range into an open circuit.

IF OUTPUT: 50 Ω impedance, 150 kHz to 2.5 MHz, -27 dBm to -3 dBm.

10 MHz REFERENCE OUTPUT: 50 Ω impedance, TTL levels (0V to >2.2V into an open circuit). Available only with Option 002 1×10^{-9} /day internal reference.

10 MHz REFERENCE INPUT¹⁹: >500 Ω impedance, 0.5V_{peak-to-peak} minimum input level.

LO INPUT (Option 003): 50 Ω impedance, ~1.27 MHz to 1301.5 MHz, 0 dBm nominal.

RF SWITCH REMOTE CONTROL OUTPUT: Provides output signals necessary to remotely control either an HP 33311B/C Option 011 or an HP 8761A RF switch.

FREQUENCY OFFSET MODE REMOTE CONTROL OUTPUT: TTL high output if in frequency offset mode (Special Function 27.1 or 27.3) with an external LO frequency >0, TTL low output for all other cases.

¹⁹ External reference accuracy affects accuracy of all measurements.

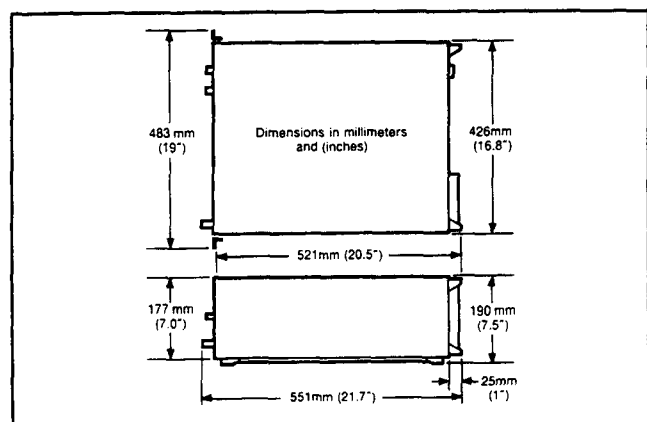

Table 1-2. Recommended Test Equipment (1 of 4)

Instrument Type	Critical Specifications	Suggested Model	Use*
AM/FM Test Source	Carrier Frequency: within range 10 to 1300 MHz Output Level: > -20 dBm FM Deviation: 400 kHz peak maximum FM Distortion: < -72 dB at 12.5 MHz carrier with 12.5 kHz deviation and <10 kHz rate < -72 dB at 400 MHz carrier and 400 kHz deviation at <100 kHz rate FM Flatness: ±0.1% from 20 Hz to 100 kHz rates ±0.25% to 200 kHz rates CW Residual FM: <3 Hz rms in a 50 Hz to 3 kHz bandwidth at 560 MHz Incidental AM: <0.08% AM at 100 MHz with <50 kHz peak deviation and 1 kHz rate in a 50 Hz to 3 kHz bandwidth AM Depth: 5% to 99% AM Distortion: < -66 dB at <50% AM at 20 Hz to 100 kHz rates < -60 dB at <95% AM at 20 Hz to 100 kHz rates AM Flatness: ±0.1% from 50 Hz to 50 kHz ±0.25% from 20 Hz to 100 kHz Incidental FM: <0.008 rad peak at 12.5 MHz with 50% AM at a 1 kHz rate in a 50 Hz to 3 kHz bandwidth Residual AM: <0.01% rms in a 50 Hz to 3 kHz bandwidth AM Linearity: ±0.1% at <95% AM ±0.2% at <99% AM	HP 11715A	P,A,T
Attenuator, 3 dB (2 required)	Frequency: 30 MHz SWR Maximum: 1.2 (Used as alternate equipment.)	HP 8491A Option 03	P
Attenuator, 6 dB	Frequency Range: 0.15 to 1300 MHz SWR Maximum: 1.2 Attenuation Accuracy: ±0.4 dB	HP 8491A Option 06	P
Audio Analyzer	Fundamental Frequency Range: 20 Hz to 100 kHz Distortion Range: -70 dB minimum Distortion Accuracy: ±2 dB Low-Pass Filters: 30 and 80 kHz Oscillator Level: 3V maximum into 600Ω Oscillator Distortion: < -70 dB Oscillator Frequency Accuracy: ±2%	HP 8903B	P,A,T
*C=Operator's Checks; P=Performance Tests; A=Adjustments; T=Troubleshooting			

Table 1-2. Recommended Test Equipment (2 of 4)

Instrument Type	Critical Specifications	Suggested Model	Use*
Audio Synthesizer	Frequency Range: 20 Hz to 400 kHz Output Level: +16 dBm (50 Ω) maximum Frequency Accuracy: $\pm 0.1\%$ Attenuator Accuracy: ± 0.1 dB from 0 to 20 dB Level Flatness: ± 0.07 dB from 20 Hz to 200 kHz Distortion: ≤ -50 dB from 20 Hz to 200 kHz	HP 3336C Option 005	P,A,T
Computing Controller	HP-IB compatibility as defined by IEEE Std 488 and the identical ANSI Std MC1.1: SH1, AH1, T2, TE0, L2, LE0, SR0, PP0, DC0, DT0, and C1, 2, 3, 4, 5.	HP 9825A and HP 98034A and HP 98213A or HP 85B Option 007	C,P,T
Digital Multimeter	DC Range: 0 to 50V DC Accuracy: $\pm 0.01\%$ at 1V AC Range: 0 to 100V AC Accuracy: $\pm 0.01\%$ at 2V and 2 kHz Ohms Range: 0 to 1 M Ω Ohms Accuracy: $\pm 1\%$	HP 3455A	P,A,T
Divider Probe (2 required)	Divider Ratio: 10:1 Input Impedance: 1 M Ω Input Capacitance: ≤ 10 pF	HP 10040A	A,T
Extender Cable	No substitution is recommended.	HP 08901-60179	A,T
Frequency Standard	Accuracy: ± 0.1 ppm recommended	House Standard	A
Oscilloscope	Bandwidth: less than 3 dB down 0 to 100 MHz Sensitivity: 5 mV per division minimum Input Impedance: 10 M Ω and 50 Ω Triggering: External and Internal	HP 1740A	C,A,T
Piston Attenuator	Accuracy: $\pm(0.005$ dB/10 dB + 0.03 dB) at 30 MHz (Used as alternate equipment.)	Eaton Type 32	P
*C=Operator's Checks; P=Performance Tests; A=Adjustments; T=Troubleshooting			

Table 1-2. Recommended Test Equipment (3 of 4)

Instrument Type	Critical Specifications	Suggested Model	Use*
Power Meter or Power Reference	Power Range: 1 mW Frequency Range: 50 MHz SWR: 1.05 Accuracy: $\pm 0.5\%$; NBS calibrated Power Output: 1.00 mW, factory set to $\pm 0.7\%$, NBS calibrated Accuracy: $\pm(1.2\%$ worst case $+0.9\%$ rss) for one year; 0 to 50° C	HP 432A and HP 478A Option H75 HP 435A Option K05	P,A
Power Supply	Output Range: 0 to 25 Vdc	HP 6215A	T
Range Calibrator	Calibration Functions: outputs corresponding to power displays of 10 μ W, 100 μ W, 1 mW, 10 mW, and 100 mW Calibration Uncertainty: $\pm 0.25\%$ in all ranges	HP 11683A	P,A,T
RF Spectrum Analyzer	Frequency Range: 0 to 2 GHz Input Level: ± 10 dBm maximum Display Range: 60 dB	HP 8559A and HP 182T	A,T
Sensor Module	Compatible with HP 8902A Input SWR: <1.3, at RF Input, RF Ranges 1 and 2 <1.5, at RF Input, RF Range 3 <1.3, at RF Input, RF Range 3 with Measuring Receiver's Special Function 1.9	HP 11722A	P,A,T
Service Accessory Kit	No substitution recommended.	HP 08901-60287	T
Signal Generator	Frequency Range: 0.5 to 1100 MHz Output Level: +19 dBm maximum to 500 MHz +13 dBm maximum to 1100 MHz Output Level Accuracy: ± 1 dB Frequency Accuracy: $\pm 1\%$ Frequency Resolution: 1 kHz Modulation Capability: AM and FM AM Depth: 0 to 95% AM Accuracy: $\pm 10\%$ FM Range: 0 to 400 kHz peak deviation FM Accuracy: $\pm 10\%$	HP 8640B Options 001 and 002	C,P,A T
*C=Operator's Checks; P=Performance Tests; A=Adjustments; T=Troubleshooting			

Table 1-2. Recommended Test Equipment (4 of 4)

Instrument Type	Critical Specifications	Suggested Model	Use*
Signature Analyzer	External Count Range: to 15 MHz Because the signatures documented are unique to a given signature analyzer, no substitution is recommended.	HP 5005A	T
Step Attenuator	Step Accuracy: ± 0.01 dB between 10 and 20 dB at 50 MHz	HP 355D Option J25	P
SWR Bridge	Frequency Range: 150 kHz to 1300 MHz Impedance: 50Ω Directivity: >40 dB Connectors: Type-N	Wiltron 60N50	P
*C=Operator's Checks; P=Performance Tests; A=Adjustments; T=Troubleshooting			

Table 1-3. Recommended Test Accesories

Accessory Type*	Recommended Part
Adapter (Type N Male to BNC Female connectors)	HP 1250-0067
Capacitor, 620 pF	HP 0160-3536
IC Extender Clip, 16 Pin	HP 1400-0734
Resistor, 909 Ω 1% 1/4W	HP 0757-0422
Resistor, 1210 Ω 1% 1/4W	HP 0757-0274
Resistor, 2150 Ω 1% 1/4W	HP 0698-0084
Resistor, 4640 Ω 1% 1/4W	HP 0698-3155
Tee (Coaxial, BNC, one Male and two Female connectors)	HP 1250-0781
50 Ω Load (Male, BNC, coaxial)	HP 1250-0207
Adjustment Tool	HP 8710-0772
*Accessories listed in this table are only those not already contained in the Service Accessory Kit HP 08901-60287	

Section 2 INSTALLATION

2-1. INTRODUCTION TO THIS SECTION

This section provides the information needed to install the Measuring Receiver. Included is information pertinent to initial inspection, power requirements, line voltage selection, power cables, interconnection, operating environment, instrument mounting, storage and shipment. This section also contains a procedure for setting the internal HP-IB talk and listen address switches and a procedure for removing the pull-out cards.

2-2. INITIAL INSPECTION

WARNING

To avoid hazardous electrical shock, do not perform electrical tests when there are signs of shipping damage to any portion of the outer enclosure (covers, panels, meters).

Inspect the shipping container for damage. If the shipping container or cushioning material is damaged, it should be kept until the contents of the shipment have been checked for completeness and the instrument has been checked mechanically and electrically. Procedures for checking electrical performance are given in Section 4. If the contents are incomplete, if there is mechanical damage or defect, or if the instrument does not pass the electrical performance test, notify the nearest Hewlett-Packard office. If the shipping container is damaged, or the cushioning material shows signs of stress, notify the carrier as well as the Hewlett-Packard office. Keep the shipping materials for the carrier's inspection.

2-3. PREPARATION FOR USE

Power Requirements

WARNING

To avoid the possibility of hazardous electrical shock, do not operate this instrument at line voltages greater than 126.5 Vac with line frequencies greater than 66 Hz. Leakage currents at these line settings may exceed 3.5 mA.

The Measuring Receiver requires a power source (+5% to -10%) of 100, 120, 220, or 240 Vac, 48 to 66 Hz single phase. Option 004 also operates from 48 to 440 Hz single phase, 120 Vac, (+5% to -10% only). Power consumption is 200 VA maximum.

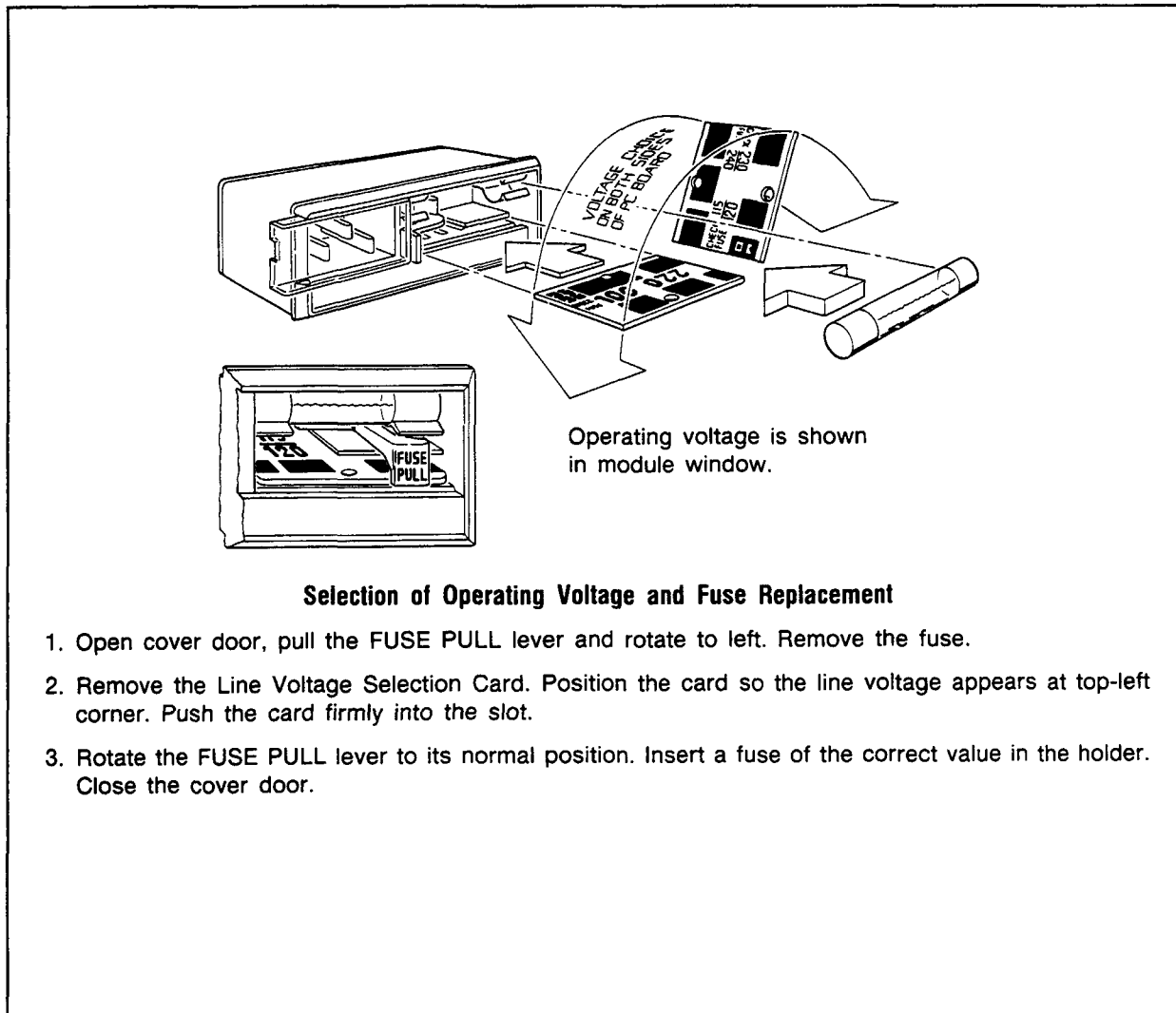

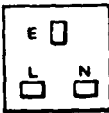

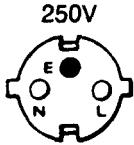
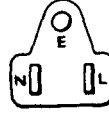
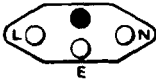
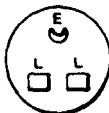
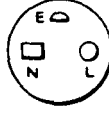

Figure 2—1. Line Voltage and Fuse Selection

WARNING

This is a Safety Class I product (that is, provided with a protective earth terminal). An uninterruptible safety earth ground must be provided from the main power source to the product input wiring terminals, power cord, or supplied power cord set. Whenever it is likely that the protection has been impaired, the product must be made inoperative and be secured against any unintended operation.

If this instrument is to be energized via an external autotransformer, make sure the autotransformer's common terminal is connected to the earthed pole of the power source.

Table 2-2. AC Power Cables Available

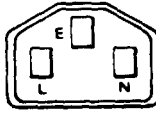
Plug Type	Cable HP Part Number	C D	Plug Description	Cable Length (inches)	Cable Color	For Use In Country
250V 	8120-1351 8120-1703	0 4	90°/STR BS1363A* 90°/90°	90 90	Mint Gray Mint Gray	United Kingdom, Cyprus, Nigeria, Rhodesia, Singapore
250V 	8120-1369 8120-0696	0 4	STR/STR NZSS198/ASC112* STR/90°	79 80	Gray Gray	Australia, New Zealand
250V 	8120-1689 8120-1692	7 2	STR/STR* STR/90°	79 79	Mint Gray Mint Gray	East and West Europe, Saudi Arabia, Egypt, (unpolarized in many nations)
125V 	8120-1378 8120-1521	1 6	STR/STR NEMA5-15P* STR/90°	80 80	Jade Gray Jade Gray	United States, Canada, Mexico, Phillipines, Taiwan
100V (Same plug as above)	8120-1751	1	STR/STR	90	Jade Gray	U.S./Canada
250V 	8120-2104	3	STR/STR SEV1011 1959-24507 Type 12	79	Gray	Switzerland
	8120-2296	4	STR/90°	79	Gray	
	8120-3997	4	STR/90°	177	Gray	
250V 	8120-0698	6	STR/STR NEMA6-15P	90	Black	United States, Canada
250V 	8120-2956	3	90°/STR	79	Gray	Denmark
	8120-2957	4	90°/90°			
	8120-3997	4	STR/STR			
250V 	8120-4211 8120-4600	7 8	STR/STR*IEC83-B1 STR/90°	79 79	Black Gray	South Africa, India
250V 	8120-1860	6	STR/STR*CEE22-V1 (Systems Cabinet Use)	59	Jade Gray	
	8120-1575	0	STR/STR	31	Jade Gray	
	8120-2191	8	STR/90°	59	Jade Gray	
	8120-4379	8	90°/90°	80	Jade Gray	

* Part number shown for plug is industry identifier for plug only. Number shown for cable is HP Part Number for complete cable including plug. E = Earth Ground; L = Line; N = Neutral; STR = Straight

Line Voltage and Fuse Selection

CAUTION

BEFORE PLUGGING THIS INSTRUMENT into the Mains (line) voltage, be sure the correct voltage and fuse have been selected.

Verify that the line voltage selection card and the fuse are matched to the power source. Refer to Figure 2-1, *Line Voltage and Fuse Selection*.

Fuses may be ordered under HP part numbers 2110-0083, 2.5A (250V normal blow) for 115 Vac operation and 2110-0043, 1.5A (250V normal blow) for 230 Vac operation.

Power Cables

WARNING

BEFORE CONNECTING THIS INSTRUMENT, the protective earth terminals of this instrument must be connected to the protective conductor of the (Mains) power cord. The Mains plug shall only be inserted in a socket outlet provided with a protective earth contact. The protective action must not be negated by the use of an extension cord (power cable) without a protective conductor (grounding).

This instrument is equipped with a three-wire power cable. When connected to an appropriate ac power receptacle, this cable grounds the instrument cabinet. The type of power cable plug shipped with each instrument depends on the country of destination. Refer to Table 2-1 for the part numbers of the power cables available.

HP-IB Address Selection

The HP-IB address switches are located within the Measuring Receiver. The switches represent a five-bit binary number. This number represents the talk and listen address characters which an HP-IB controller must generate. In addition, two more switches allow the Measuring Receiver to be set to talk only or to listen only.

WARNING

Setting of the HP-IB address should be performed only by service trained persons who are aware of the potential shock hazard of working on an instrument with protective covers removed.

To avoid hazardous electrical shock, the line (Mains) power cable should be disconnected before attempting to change the HP-IB address.

In the Measuring Receiver, the HP-IB talk and listen addresses are selectable by an internal switch (Figure 2-2). This address can be read by selecting BUS ADRS (Blue Key, LOCAL). The following procedure explains setting of the switches. Refer to Table 2-2 for a listing of the talk and listen addresses. In the factory, the address is set for a talk address of "N" and a listen address of "." (period). In binary, this is 01110; in decimal it is 14.

1. Disconnect the line (Mains) power cable.
2. Remove any HP-IB cables or connectors from the HP-IB connector.
3. Remove the Measuring Receiver's top cover.

- a. Remove the two plastic feet from the rear of the top cover by removing the pan-head Pozidriv screw within each foot.
 - b. Unscrew the Pozidriv screw at the center of the rear edge of the top cover. This is a captive screw and will cause the top cover to pull away from the front frame.
 - c. Lift off the top cover.
4. Locate the HP-IB address switch on the A14 Remote Interface Assembly near the front right of the instrument. The A14 assembly may be recognized as having one brown and one yellow printed circuit board extractor.

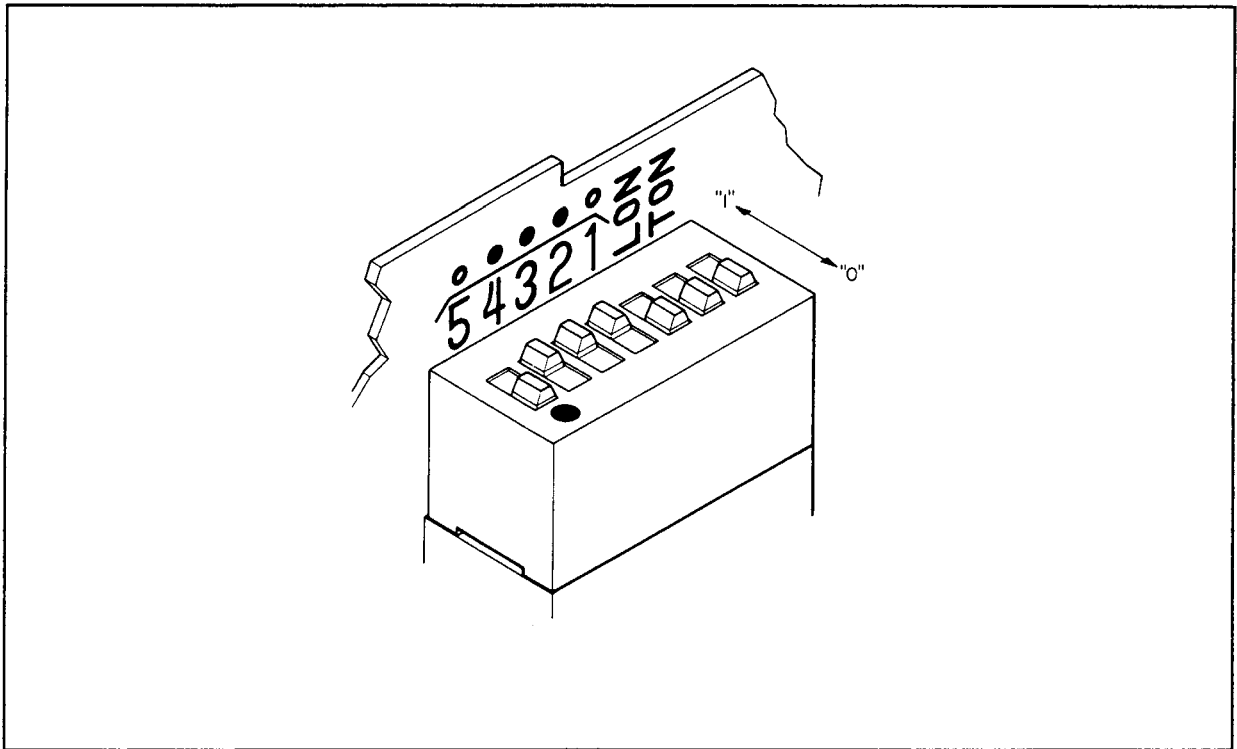

*Figure 2-2. The HP-IB Address Switch Shown as Set by the Factory
The Address Shown is 01110 in Binary (14 in Decimal) With Both Talk Only and Listen Only Off*

5. Use a pencil to set the switches to the desired HP-IB address and Talk Only (TON) or Listen Only (LON) condition. The switch is illustrated in Figure 2-2. Facing the board, the left hand switch (marked with a "5") is the most significant address bit (A5 in Table 2-2). Setting a switch toward the printed circuit board places it in its "1" position. If the TON and LON switches are both set to "1", the Talk Only setting will override. If the address switches and the TON switch are all set to "1", the Measuring Receiver will output one byte (the status byte) each measurement cycle. (Setting all switches to "1" defeats HP-IB operation.)
6. Reinstall the top cover by reversing the procedure in previous step 3.
7. Connect the line (Mains) power cable to the Line Power Module and reconnect the HP-IB cable to the HP-IB connector.
8. To confirm the address, turn on the instrument and select BUS ADRS (Blue Key, LOCAL). To confirm a talk only or listen only setting, key in 21.0 SPCL. The display shows a binary

number in the form AAAAA.TLS where AAAAA is the HP-IB address in binary and T,L, and S indicate talk, listen, and service request status.

Table 2-2. Allowable HP-IB Address Codes

Address Switches					Talk Address Character	Listen Address Character	Decimal Equivalent
A5	A4	A3	A2	A1			
0	0	0	0	0	@	SP	0
0	0	0	0	1	A	!	1
0	0	0	1	0	B	"	2
0	0	0	1	1	C	#	3
0	0	1	0	0	D	\$	4
0	0	1	0	1	E	%	5
0	0	1	1	0	F	&	6
0	0	1	1	1	G	'	7
0	1	0	0	0	H	(8
0	1	0	0	1	I)	9
0	1	0	1	0	J	•	10
0	1	0	1	1	K	+	11
0	1	1	0	0	L	,	12
0	1	1	0	1	M	-	13
0	1	1	1	0	N	.	14
0	1	1	1	1	O	/	15
1	0	0	0	0	P	0	16
1	0	0	0	1	Q	1	17
1	0	0	1	0	R	2	18
1	0	0	1	1	S	3	19
1	0	1	0	0	T	4	20
1	0	1	0	1	U	5	21
1	0	1	1	0	V	6	22
1	0	1	1	1	W	7	23
1	1	0	0	0	X	8	24
1	1	0	0	1	Y	9	25
1	1	0	1	0	Z	:	26
1	1	0	1	1	[;	27
1	1	1	0	0	\	<	28
1	1	1	0	1]	=	29
1	1	1	1	0	^	>	30
1	1	1	1	1	Invalid	Invalid	31

Interconnections

Interconnection data for the Hewlett-Packard Interface Bus is provided in Figure 2-3.

Mating Connectors

Interface Connector The HP-IB mating connector is shown in Figure 2-3. Note that two securing screws are metric.

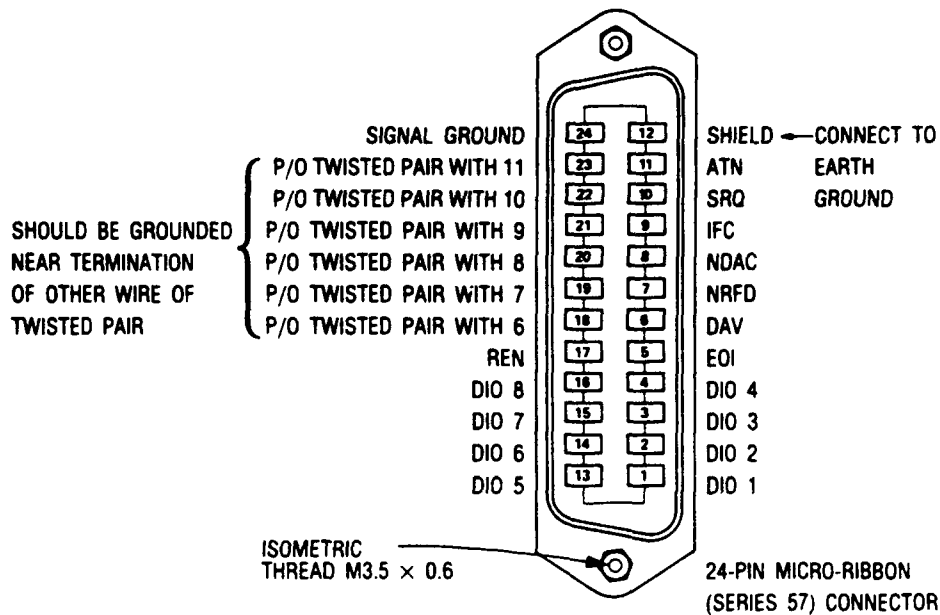

Logic Levels

The Hewlett-Packard Interface Bus logic levels are TTL compatible, that is, the true (1) state is 0.0 Vdc to +0.4 Vdc and the false (0) state is 2.5 Vdc to +5 Vdc.

Programming and Output Data Format

Refer to Section 3 "Operation".

Mating Connector

HP 1251-0293; Amphenol 57-30240

Mating Cables Available

HP 10833A, 1 meter (3.3 ft.), HP 10833B 2 meters (6.6 ft.)
 HP 10833C 4 meters (13.2 ft.), HP 10833D, 0.5 meters (1.6 ft.)

Cabling Restrictions

1. A Hewlett-Packard Interface Bus system may contain no more than 2 meters (6.6 ft.) of connecting cable per instrument.
2. The maximum accumulative length of connecting cable for any Hewlett-Packard Interface Bus system is 20 meters (65.6 ft.).

Figure 2-3. Hewlett-Packard Interface Bus Connection

Coaxial Connectors Coaxial mating connectors used with the Measuring Receiver should be the 50 Ω BNC male connectors or 50 Ω Type-N male connectors that are compatible with those specified in US MIL-C-39012.

The application note, "Principles of Microwave Connector Care" (HP part number 5958-7442) can help you improve measurements and reliability. Suggestions in the application note will help you get the best performance from all microwave connectors. It will show what to look for when cleaning and inspecting connectors (in order to preserve their precision and extend their life) and how to make the best possible microwave connections (improving the accuracy and repeatability of all your measurements).

Operating Environment

The operating environment should be within the following limitations:

Temperature	-0°C to +55°C
Humidity	<95% relative
Altitude	4570 meters (15 000 feet)

Bench Mounting

The instrument cabinet has plastic feet and fold-away tilt stands for convenience in bench operation. (The plastic feet are shaped to ensure self-aligning of the instruments when stacked.) The tilt stands raise the front of the instrument for easier viewing of the front panel.

Rack Mounting

WARNING

The Measuring Receiver is heavy for its size (23.6 kg, 52 lb). Care must be exercised when lifting to avoid personal injury. Use equipment slides when rack mounting.

Rack mounting information is provided with the rack mounting kits. If the kits were not ordered with the instrument as options, they may be ordered through the nearest Hewlett-Packard office. (Refer to paragraph 1-8, *Additional Equipment Information under Mechanical Equipment Available*. Before rack mounting the Measuring Receiver, the *Operating Information* pull-out tray (attached to the bottom of the instrument) must first be removed. To remove the pull-out card assembly, refer to the procedure that follows.

Removal and Installation of Operating Information Pull-Out Cards

Steps for Removal Follow the procedure below to remove the *Operating Information* pull-out card assembly:

1. Remove the two front feet of the instrument.
2. Remove the Operating Information tray assembly by sliding the tray toward the rear of the instrument and then down.
3. Remove the information cards by bowing them slightly in the middle and pulling it straight up (away from the tray).

Steps for Installation Follow the procedure below to reinstall the *Operating Information* pull-out card assembly:

1. Install the information card by bowing it slightly in the middle and carefully guiding the edges into the plastic guide slots near the front of the tray.
2. Push the information card all the way into the tray.
3. Place the information tray assembly between the rear feet of the instrument and slide it forward until the tabs are locked under the rear feet.
4. Replace the front feet of the instrument.

2-4. STORAGE AND SHIPMENT

Environment

The instrument should be stored in a clean, dry environment. The following environmental limitations apply to both storage and shipment:

Temperature	-55°C to +75°C
Humidity	<95% relative
Altitude	15 300 meters (50 000 feet)

Packaging

Original Packaging Containers and materials identical to those used in factory packaging are available through Hewlett-Packard offices. If the instrument is being returned to Hewlett-Packard for servicing, attach a tag indicating the type of service required, return address, model number and full serial number. Also mark the container FRAGILE to assure careful handling. In any correspondence refer to the instrument by model number and full serial number.

Other Packaging The following general instructions should be used for re-packaging with commercially available materials:

1. Wrap the instrument in heavy paper or plastic. (If shipping to a Hewlett-Packard office or service center, attach a tag indicating the service required, return address, model number and full serial number.)
2. Use a strong shipping container. A double-wall carton made of 2.4 MPa (350 psi) test material is adequate.
3. Use enough shock-absorbing material (75 to 100 mm layer; 3 to 4 in.) around all sides of instrument to provide firm cushion and prevent movement in the container. Protect the front panel with cardboard.
4. Seal the shipping container securely.
5. Mark the shipping container FRAGILE to assure careful handling.

Section 3 OPERATION

3-1. INTRODUCTION TO THIS SECTION

This section provides advanced operating information for the Measuring Receiver. Included in this section are descriptions of all front- and rear-panel controls, connectors, and indicators, remote and local operator's checks, operating instructions, and operator's maintenance.

Local Operation Section

Information regarding front-panel operation of the Measuring Receiver is provided in the sections described in the following paragraphs. To most rapidly learn the basic operation of the instrument, refer to the separate *Basic Operation and Application Guide* and/or perform the *Operator's Checks*. Once familiar with the general operation of the instrument, use the *Detailed Operating Instructions* for the most in-depth and complete information on operating the Measuring Receiver.

Remote Operation Section

The Measuring Receiver is capable of remote operation via the Hewlett-Packard Interface Bus (HP-IB). Provided in this section are instructions pertinent to HP-IB operation including all specific considerations and instructions (including capabilities, address formats, input and output formats, the status byte, and service requests). At the end of the discussion is a complete summary of all codes and formats.

HP-IB information concerning remote information also appears in several other locations. Address setting is discussed in Section 2, a summary of HP-IB codes and output formats appears on the *Operating Information* pull-out card, and a list of relevant program codes for each function appears in the *Detailed Operating Instructions*. (Detailed Operating Instructions are described above in the paragraph, *Local Operation Section*.)

Basic Functional Checks Section

Basic Functional Checks are simple procedures designed to be performed by the operator. These checks verify the proper operation of the Measuring Receiver's main functions and HP-IB capabilities. These checks can also be used to familiarize the first-time operator with basic Measuring Receiver measurements and HP-IB capabilities. Two procedures are provided:

Basic Functional Checks of the Measuring Receiver

This procedure assures that most front-panel controlled functions are being properly executed by the Measuring Receiver. The checks require the use of a sensor module, a signal generator, an oscilloscope, and interconnecting cables and adapters.

Basic Functional Checks of the Hewlett-Packard Interface Bus (HP-IB)

This series of procedures requires only an HP-IB compatible computing controller and an HP-IB interface and connecting cable. The *HP-IB Functional Checks* assume that front-panel operation has been verified (for example, by performing the *Basic Functional Checks*).

Detailed Operating Instructions Section

The *Detailed Operating Instructions* provide a complete operating reference for the Measuring Receiver user. The instructions are organized into tabbed sections oriented toward specific measurement types. Besides information on the various measurements, the instructions contain individual discussions of nearly all controls, inputs, and outputs. Also included are instructions for using the many user special functions. A guide to using the *Detailed Operating Instructions* is provided ahead of the instructions themselves.

Other Sources of Operating Information

Pull-Out Cards

The *Operating Information* and *Special Function Information Pull-Out Cards* are flexible plastic reference sheets attached to the Measuring Receiver by a tray located beneath the front panel. They contain a brief summary of front-panel operation and displays. Also included on the cards is a complete listing of HP-IB codes, data, and error output formats, error codes, and user special functions. The cards show a simplified block diagram for the Measuring Receiver and provide basic instructions for RF Power and Tuned RF Level Measurement operation. The pull-out cards are intended to be a reference for the user who already has a basic understanding of front-panel operation.

Supplemental Information

Other information, pertinent to operating the Measuring Receiver to its fullest capabilities, are contained in *Section 1*. "Principles of Operation for a Simplified Block Diagram" (in paragraph 1-10) is a fundamental description of what the Measuring Receiver is and how it works. This information supplements the block diagrams provided on the pull-out card and in the *Detailed Operating Instructions*. "Modulation Basics" (in paragraph 1-11) is a discussion about the way the Measuring Receiver makes modulation measurements. All of this information helps to provide a basis for applying the Measuring Receiver to various measurement situations.

3-2. OPERATING CHARACTERISTICS OF THE MEASURING RECEIVER

The major operating characteristics of the Measuring Receiver are provided in paragraph 1-6, *Description*, and Table 1-1, *Specifications*. For information on HP-IB capabilities, refer to *Remote* section in this manual.

3-3. OPERATOR'S INFORMATION

Fuses

WARNING

For continued protection against fire hazard, replace the line fuse only with a 250V normal blow fuse of the same rating. Do not use repaired fuses or short-circuited fuseholders.

The only maintenance the operator should normally perform is the replacement of the primary power fuse located within the Line Power Assembly (A30). For instructions on how to change the fuse, refer to Figure 2-1, steps 1 and 3.

Fuses can be ordered using HP part number 2110-0083, 2.5A (250V, normal blow) for 100/120 Vac operation or 2110-0043, 1.5A (250V, normal blow) for 220/240 Vac operation.

Time Base 10 MHz Input and Time Base 10 MHz Output

WARNING

Do not apply greater than 20V peak (ac + dc) into the TIME BASE 10 MHz INPUT or damage to the instrument may result.

Do not apply greater than 3 Vdc or greater than +20 dBm into the TIME BASE 10 MHz OUTPUT or damage to the instrument may result.

Description

Time Base 10 MHz Input. Provides an input for an external 10 MHz time base reference. This input is ac coupled and requires an input signal level greater than 0.5 Vpp. The input impedance is approximately 500Ω.

The time-base circuitry of the Measuring Receiver automatically switches to the external time base when an external time base of sufficient amplitude is applied.

When using an external time base reference, the accuracy of all measurements depends on the accuracy of the external reference. Frequency-related measurements are most noticeably affected by time-base inaccuracy.

To determine whether the Measuring Receiver has actually switched in the externally applied time base, select 15.1 SPCL. If an external time base is being used, the display will show a 1. If the internal time base is being used, the display will show a 0.

If the Measuring Receiver is using the internal, Option 002 time base, you can determine whether the time base oven is warm enough to create a stable source by selecting 15.0. The display will show a 0 if the time base oven is adequately warm. The display will show Error 12 if the time base is cold.

To drive several instruments from a single external reference, simply use a BNC tee at the Measuring Receiver's TIME BASE 10 MHz INPUT.

If the internal time base fails, an external time base may still be used. Connect the external time base to TIME BASE 10 MHz INPUT, then switch the instrument's POWER switch to STBY and back to ON.

Time Base 10 MHz Output. (This output is available only with the high-stability reference, Option 002.) Provides an output for the internal 10 MHz reference. The output is a 50Ω, TTL compatible output (0V to greater than 2.2V into an open circuit).

When driven from an external reference, the Measuring Receiver outputs the internal reference (not the external input signal). TIME BASE 10 MHz INPUT provides an input for an external 10 MHz time base reference. This input is ac coupled and requires an input signal level greater than 0.5 Vpp. The input impedance is approximately 500Ω.

3-4. TURN-ON PROCEDURE

WARNING

Before the Measuring Receiver is switched on, all protective earth terminals, extension cords, auto-transformers, and devices connected to it should be connected to a protective earth socket. Any interruption of the protective earth grounding will cause a potential shock hazard that could result in personal injury.

For continued protection against fire hazard, replace the line fuse with a 250V normal blow fuse of the same rating. Do not use repaired fuses or short-circuited fuseholders.

CAUTION

Before the Measuring Receiver is switched on, it must be set to the voltage of the power source, or damage to the instrument may result. Refer to paragraph 2-3, Power Requirements.

Do not apply greater than 40V (ac + dc) to the RF INPUT connector or damage to the instrument may result.

The Measuring Receiver has a standby state and an on state. Whenever the power cable is plugged in, an internal power supply is activated. In instruments supplied with the high-stability reference (Option 002) the supply energizes the internal reference oven. If the Measuring Receiver is already plugged in, set the POWER switch to ON. If the power cable is not plugged in, follow these instructions:

1. Check that the line voltage setting matches the power source. (See Figure 2-1, *Line Voltage and Fuse Selection*.)
2. Check that the fuse rating is appropriate for the line voltage used. (See Figure 2-1, *Line Voltage and Fuse Selection*.) Fuse ratings are provided in the paragraph *Operator's Maintenance* in this section.
3. Plug in the power cable.
4. Set the POWER switch to ON.

NOTE

When the POWER switch is set to ON, all front-panel indicators light for approximately 10 seconds after which the instrument is ready to be operated.

3-5. INSTRUMENT FEATURES

Front-panel controls, indicators, and connectors are illustrated and referenced to text in Figure 3-1. The text for this figure describes the various functions of the Measuring Receiver. At the end of each description is a reference to a detailed operating instruction that contains more details on this topic.

Rear-panel features are shown and referenced to text in Figure 3-2. The text for this figure provides a quick reference for rear-panel signal levels and frequencies and also includes the impedances at the rear-panel connections.

The information in parenthesis at the end of each feature summary provides the title of the *Detailed Operating Instructions* relevant to the feature.

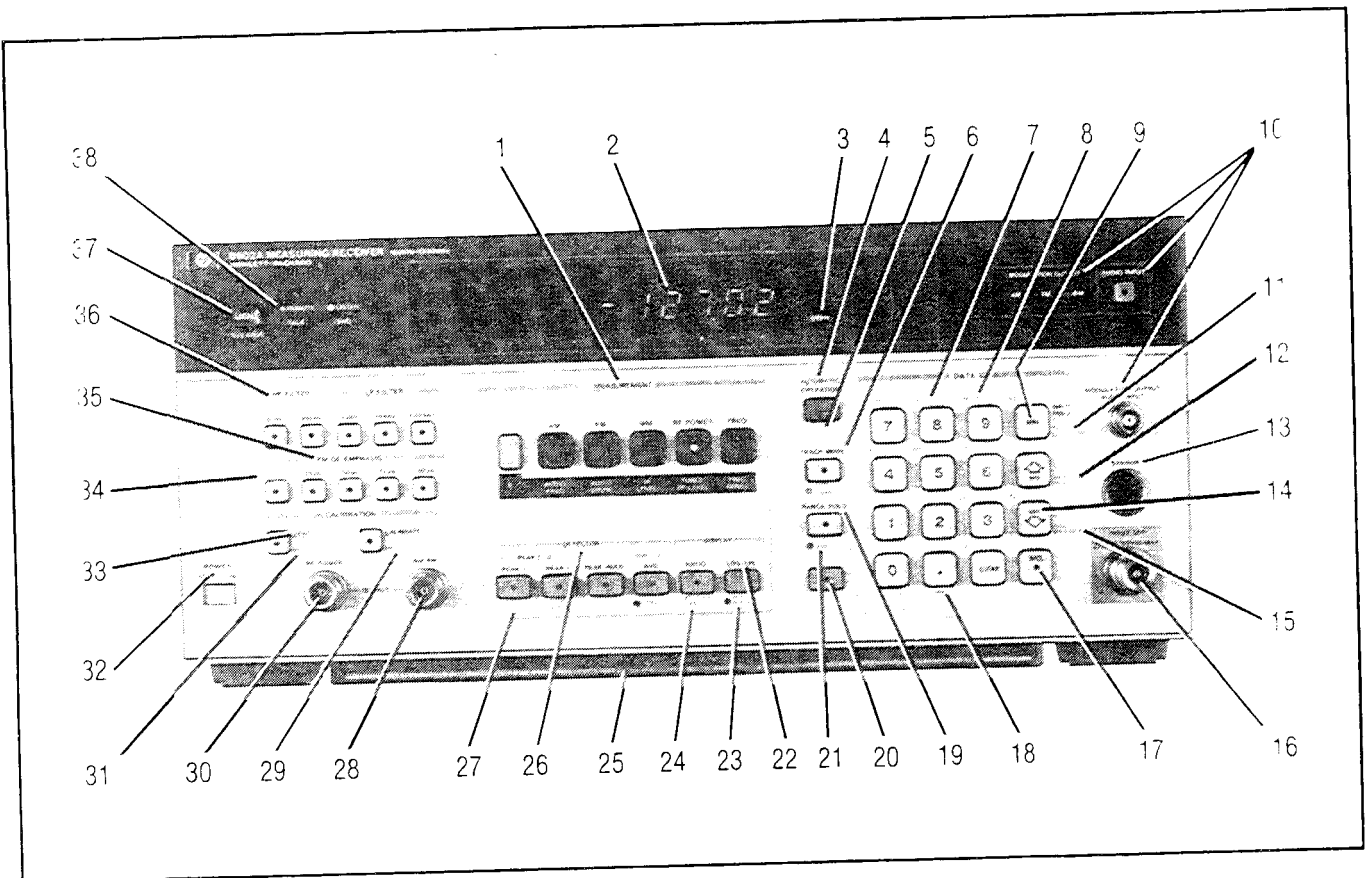

Figure 3-1. Front-Panel Features

Front-Panel Features

The following list provides a brief description of each feature. The information in brackets provides the title of the *Detailed Operating Instructions* relevant to the feature. The index lists page numbers for the instructions.

1. MEASUREMENT keys enable the Measuring Receiver to make and display the selected measurement. [See *AM, FM, Φ M, RF Power, RF Input Frequency, Audio Frequency, Audio Distortion, IF Level, Tuned RF Level, RF Frequency Error.*]
2. Numeric Display shows measurement results, error codes, or instrument or Special Function status.
3. Display Annunciators indicate the measurement result units. They also indicate that some measurement functions are enabled. All these annunciators are displayed when the Measuring Receiver is first turned on.
4. AUTOMATIC OPERATION enables the Measuring Receiver to automatically tune and to autorange to make the selected measurement. [See *Automatic Operation.*]
5. INSTR PRESET (Blue Key) configures the Measuring Receiver to its power-up condition. [See *Instrument Preset.*]
6. TRACK MODE and AUTO TUNING (Blue Key) select the tuning mode of the Measuring Receiver. [See *RF Frequency Tuning.*]
7. STORE (Blue Key) and RECALL (Blue Key) enable the Measuring Receiver to store and recall up to eight measurement states. [See *Store/Recall.*]
8. WATTS, μ V, mV, and VOLTS keys (all used with the Blue Key) enable selection of different units for level measurements.
9. MHz completes the keyboard entry of frequencies for various functions. This key is also used to complete the entry of frequencies used with RF Power calibration factors. [See *RF Frequency Tuning, Frequency Offset Mode, RF Power.*]
10. MODULATION OUTPUT/AUDIO INPUT connector provides either an output for the modulation recovered from the RF INPUT connector or an input for external audio signals to be processed by the audio circuitry. The MODULATION OUTPUT annunciators indicate the type of recovered modulation available as the output. The AUDIO INPUT key selects whether the internally demodulated signal or an external audio signal is to be processed by the Measuring Receiver's audio circuitry. [See *Modulation Output/Audio Input, Audio Frequency, Audio Distortion and Level, SINAD.*]
11. % CAL FACTOR (Blue Key) causes the Measuring Receiver to display the current calibration factor for the selected measurement. This key is also used to complete the entry of calibration factors for various functions. [See *AM Calibration, FM Calibration, RF Power, Tuned RF Level.*]
12. DISPLAY FREQ (Blue Key) causes the Measuring Receiver to display the RF frequency that it tuned to last. [See *Frequency Offset Mode, RF Power Calibration Factors.*]
13. SENSOR connector provides the input for the power sensor. [See *RF Power.*]
14. kHz \uparrow and kHz \downarrow complete keyboard entry of frequency step-size (in kHz) for step tuning, or change the frequency in the increments specified. [See *RF Frequency Tuning.*]
15. DISPLAY FREQ INCR (Blue Key) causes the Measuring Receiver to display the increment step-size. [See *RF Frequency Tuning.*]
16. INPUT couples the RF input signal into the instrument. [See *RF Input Frequency.*]
17. SPCL completes entry of Special Function codes that access additional instrument operations. Without a preceding numeric entry, the SPCL key causes a display of the status of Special Functions 1 through 10. [See *Special Functions.*]

18. (–) (Blue Key) enables input data to be entered as a negative value.
19. RANGE HOLD freezes the current ranges being used by the Measuring Receiver. [See *Range Hold*.]
20. Blue Key is a shift key that enables some keys to have two different functions. Any function printed in blue can be selected when the key associated with it is pressed after the Blue Key. (The Blue Key flashes at the current measurement rate whenever it is pressed.)
21. DISABLE ERROR (Blue Key) disables Error 01 through Error 04. [See *Error Message Disable Control*.]
22. LOG/LIN causes measurements to alternate between logarithmic and linear units. [See *Ratio and Log/Lin*.]
23. dB EXT ATTEN (Blue Key) enables level measurements to be offset with external attenuation or gain. [See *External Attenuation*.]
24. RATIO and PREVIOUS RATIO (Blue Key) cause the current measurement to be compared to a reference. [See *Ratio and Log/Lin*.]
25. *Operating Information* pull-out cards are quick operating references that list Special Function, HP-IB, and Error codes, show a simplified block diagram for the Measuring Receiver, and provide basic information for RF Power and Tuned RF Level operation.
26. DETECTOR keys select the audio detector used to measure the modulation. [See *Audio Detectors, Audio Distortion and Level, SINAD*.]
27. 1 kHz DISTN (Blue Key) and 400 Hz DISTN (Blue Key) enable the Measuring Receiver to make audio measurements on either 1 kHz or 400 Hz audio signals. [See *Audio Distortion and Level, SINAD*.]
28. CALIBRATION AM/FM OUTPUT makes available a precisely modulated signal used to improve the Measuring Receiver's AM or FM accuracy. [See *AM Calibration, FM Calibration*.]
29. CALIBRATE and SAVE CAL (Blue Key) enable the Measuring Receiver to calibrate and save the resulting calibration factor for either RF Power, AM, or FM. The CALIBRATE key also initiates tuned RF level calibration operations. [See *AM Calibration, FM Calibration, RF Power, Tuned RF Level*.]
30. CALIBRATION RF POWER OUTPUT makes available a 50 MHz, 1 mW power reference used to precisely determine the sensitivity of the external power sensor. [See *RF Power*.]
31. SET REF (Blue Key) enables the Measuring Receiver to accurately measure relative power changes; for example, in attenuator or amplifier measurements. [See *Attenuator Measurements*.]
32. POWER switch applies power to the Measuring Receiver when set to ON. [See *Instrument Preset*.]
33. ZERO causes the Measuring Receiver to cancel any dc offset that may be present in the power sensor. [See *RF Power*.]
34. PRE DISPLAY enables FM deviation to be measured before or after de-emphasis. [See *FM De-Emphasis*.]
35. FM DE-EMPHASIS networks equalize pre-emphasized FM. [See *FM De-Emphasis*.]
36. HP (High-Pass) and LP (Low-Pass) FILTERS limit the demodulated signal bandwidth. [See *Audio Filters*.]
37. LOCAL returns the Measuring Receiver to keyboard control from remote (HP-IB) control.
38. HP-IB Annunciators indicate remote operation status.

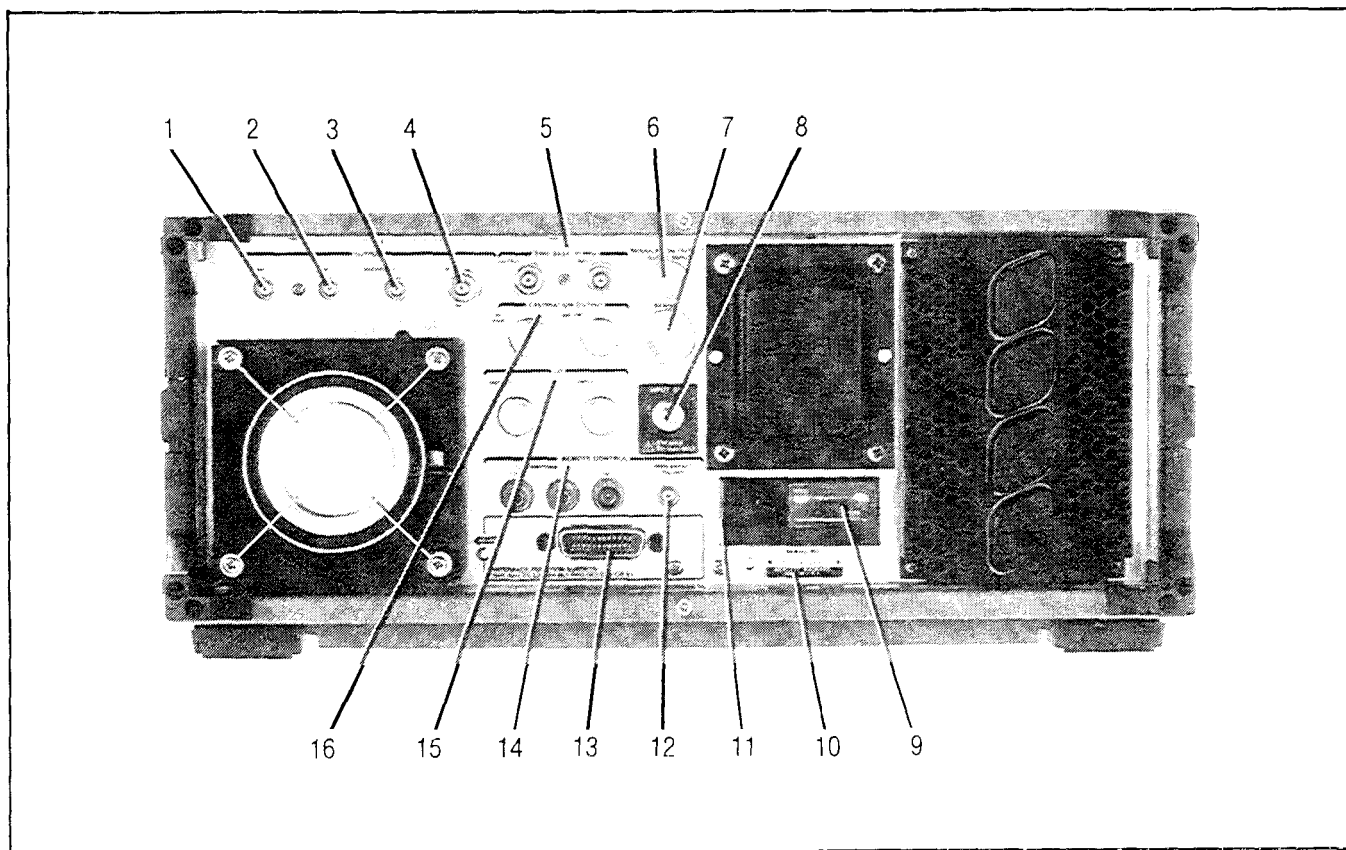

Figure 3-2. Rear-Panel Features

Rear-Panel Features

1. AM OUTPUT produces an ac signal, whose amplitude is proportional to the AM depth, with a dc component related to the IF level. The output is dc coupled with a 16 kHz bandwidth and a 10 k Ω output impedance. [See *AM Output*.]
2. FM OUTPUT produces an ac signal, whose amplitude is proportional to the FM deviation, with a dc component related to the IF frequency. The output is dc coupled with a 16 kHz bandwidth and a 10 k Ω output impedance. [See *FM Output*.]
3. RECORDER OUTPUT allows user-access to all internal measurement voltages. [See *Recorder Output*.]
4. IF OUTPUT produces a 150 kHz to 2.5 MHz modulated IF signal. The output level ranges from -27 to -3 dBm (50 Ω output impedance). [See *IF Output*.]
5. TIME BASE 10 MHz OUTPUT and INPUT. The input connector provides an input for an external 10 MHz time base reference. The external input signal must be greater than 0.5V peak-to-peak (into a 500 Ω input impedance). The output connector provides an output for the internal, high-stability 10 MHz reference. Output signal is TTL compatible (50 Ω nominal output impedance). (Refer to paragraph 3-3. *Time Base 10 MHz Input and Time Base 10 MHz Output*.)
6. MODULATION OUTPUT/AUDIO INPUT is a rear-panel output and input supplied on Option 001 instruments. Refer to MODULATION OUTPUT/AUDIO INPUT referenced from Figure 3-1.
7. SENSOR is a rear-panel input for the power sensor supplied on Option 001 instruments. Refer to SENSOR referenced from Figure 3-1.
8. INPUT is a rear-panel input for the RF input signal. This input is supplied on Option 001 instruments. Refer to INPUT referenced from Figure 3-1.
9. Fuse. 2.5A (250V normal blow) for 100 or 120 Vac. 1.5A (250V normal blow) for 220 or 240 Vac.
10. Serial Number Plate. The first four numbers and letter comprise the prefix that denotes the instrument configuration. The last five digits form the suffix that is unique to each instrument.
11. Line Power Module permits operation from 100, 120, 220, or 240 Vac. The number visible in the window indicates the nominal line voltage to which the instrument must be connected. (See Figure 2-1, *Line Voltage and Fuse Selection*) The center conductor is safety earth ground.
12. FREQ OFFSET TTL OUT outputs a voltage that can be used to switch an external mixer in and out of the path between a microwave input signal and the Measuring Receiver when the instrument is in Frequency Offset Mode. The TTL output is always 0V if Frequency Offset Mode is not selected or while Frequency Offset Mode is selected with an entered external LO value of 0 Hz. If the entered external LO frequency is less than or equal to 18 GHz, the TTL output is +5V. If the entered external LO frequency is greater than 18 GHz, the TTL output is 3V. [See *Frequency Offset Control*.]
13. HP-IB Connector connects the Measuring Receiver to the Hewlett-Packard Interface Bus for remote operations. When the HP-IB is being used, the annunciators next to the LOCAL key light as appropriate (REMOTE, LISTEN, TALK, SRQ).
14. REMOTE CONTROL RF SWITCHES enable the user to build an internal sensor module that can switch between the RF INPUT connector and the SENSOR connector. [See *Remote Control RF Switch*.]
15. LO OUTPUT and INPUT (Option 003 and Option Series 030 only). Option 003 provides an LO output connector and an LO input connector. The LO output connector is provided to output the Local Oscillator signal. The output signal is 1.27 to 1301.5 MHz at approximately 0 dBm (50 Ω) nominal output impedance. The LO input connector provides an input for an external Local Oscillator. External input signal required is 1.27 to 1301.5 MHz at approximately

0 dBm (50 Ω) nominal input impedance (LO Input and LO Output). Two jumpers are provided to allow the internal LO signal to be routed to the LO input connector when no external LO is in use.

The Option Series 030 instruments are provided with an LO input connector, an LO output connector and a remotely controllable switch which selects between them. If an external LO is connected but the signal is not in use, the switch routes the external LO signal back out the LO output connector. [See *High Selectivity Measurements*.]

CAUTION

Do not apply reverse power into the LO OUTPUT or damage to the instrument may result. Do not apply greater than 40 Vdc or +5 dBm of RF power into the LO INPUT or damage to the instrument may result.

16. CALIBRATION OUTPUT RF PWR and AM/FM produces a rear-panel output for RF Power and AM and FM calibrators. This output is supplied on Option 001 instruments instead of the standard front-panel connection. Refer to both CALIBRATION RF POWER OUTPUT and CALIBRATION AM/FM OUTPUT referenced from Figure 3-1.

HP 8902A Measuring Receiver

Basic Operation and Application Guide

HP 8902A Operation Made Easy!

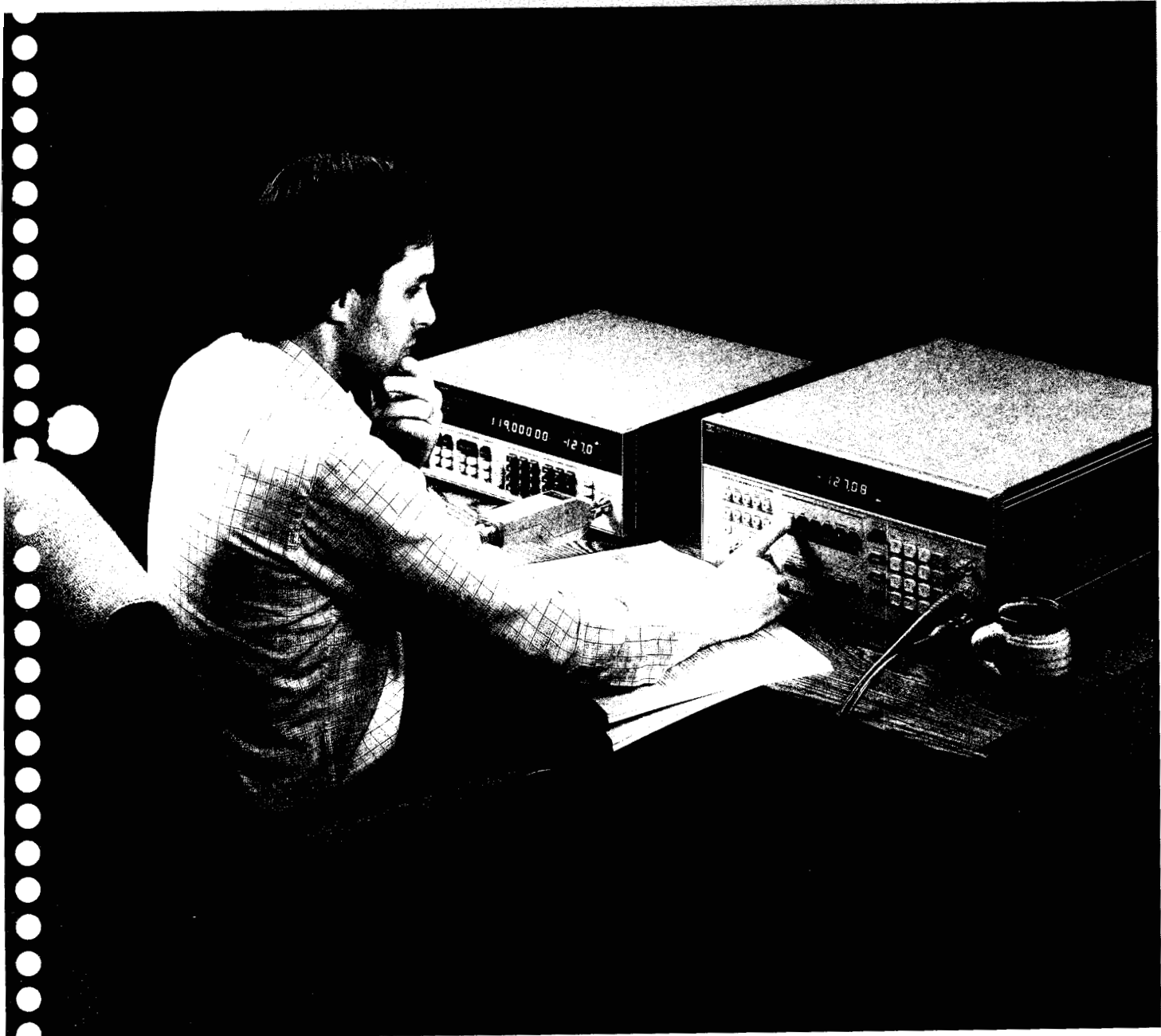

Table of Contents

1. Learning to Operate the HP 8902A

Chapter 1 provides an easy step-by-step guide to learning each of the HP 8902A's basic measurement capabilities.

2. More about RF Frequency and Frequency Error Measurements

Chapter 2 describes the HP 8902A's special capabilities that enable you to adapt the RF Frequency and Frequency Error measurements to the special conditions of your application.

3. More about Modulation and Audio Measurements

Chapter 3 describes the HP 8902A's special capabilities that enable you to adapt the Modulation and Audio measurements to the special conditions of your application.

4. More about RF Level and Tuned RF Level Measurements

Chapter 4 describes the HP 8902A's special capabilities that enable you to adapt the RF Power and Tuned RF Level measurements to the special conditions of your application.

5. Measurement Examples

Chapter 5 contains specific measurement examples that demonstrate how the versatility of the HP 8902A enables you to use it in a wide range of measurement applications.

Appendix A - Installation

Appendix B - Calibration Factors

Appendix C - Index

Appendix D - Other Publications

1

Learning to Operate the HP 8902A

The Easy Way

This Basic Operation and Application Guide is designed to provide a quick and easy way to learn to operate the HP 8902A Measuring Receiver. *Chapter 1* will provide you with all the information you need to use the HP 8902A's basic measurement capabilities: RF Frequency, Modulation, Audio, RF Power, and RF Level. The subsequent reference chapters (2 through 4) are devoted to the special functions and features that enable you to extend the operation of the HP 8902A. We strongly recommend that you first familiarize yourself with *Chapter 1* before referring to the reference chapters. Once you are comfortable with the basic operation of the instrument, it will be easier for you to understand and implement the many additional features that the HP 8902A has to offer.

The HP 8902A Solution

The hands-on approach in this chapter demonstrates the extreme versatility of the HP 8902A. Placing the HP 8902A on your bench actually puts the capabilities of several instruments at your fingertips. Many of the measurement capabilities of the following products are included in the HP 8902A.

- **RF Frequency Counter**, to 1 Hz resolution (1-5)
- **Modulation Analyzer**, AM, FM, and Φ M (1-9)
- **Audio Analyzer**, frequency, distortion, and level (1-15)
- **RF Power Meter**, as accurate as the best (1-18)
- **RF Level Meter**, unprecedented accuracy to -127 dBm . (1-21)

The HP 8902A combines many of the capabilities required for calibration, troubleshooting, and design into a single instrument. In addition, the HP 8902A's many special function capabilities enable you to adapt its measurements to the demands of a wide range of test conditions.

The Setup

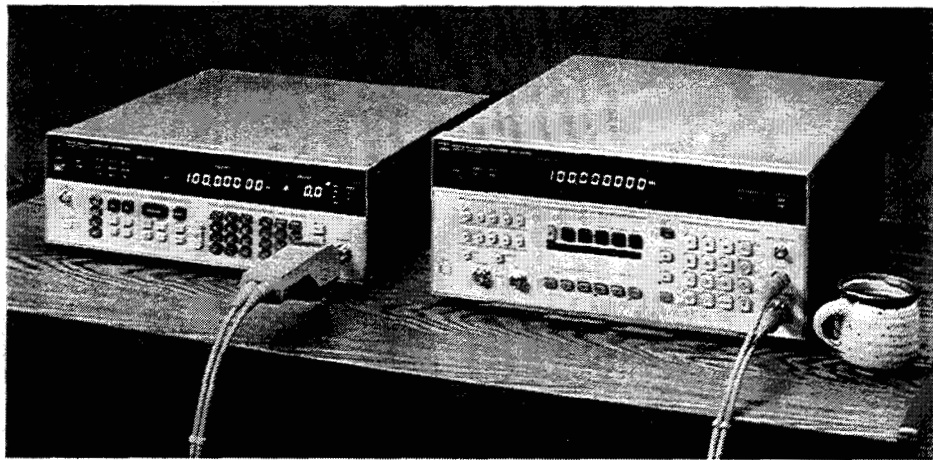

Diagram 1-1. Setup for Learning Basic Operation

To get ready to learn to use the HP 8902A, connect the HP 8902A, an HP 11722A Sensor Module, and a signal generator together as shown in Diagram 1-1.

The HP 8902A

If you are unpacking a new HP 8902A you will want to refer to the installation suggestions provided in *Appendix A*.

The HP 11722A

The procedures in this guide are written for use with an HP 11722A Sensor Module. There are many power sensors that can be used with the HP 8902A as well. If you are using a power sensor (rather than a Sensor Module), refer to your HP 8902A Operation and Calibration Manual for information on which power sensors can be used and how to operate them with the HP 8902A.

The Calibration Data

Once the HP 8902A is up and running, you will need to first determine if the calibration data for the Sensor Module you are using has been stored in the HP 8902A. *Appendix B* contains a procedure for determining whether the correct calibration data has been entered into the HP 8902A. (Refer to *Appendix B* if you are not certain that the calibration data for the Sensor Module you are using has been entered into the HP 8902A.)

The Signal Generator

The procedures in this guide are best performed using a signal generator that generates a single, stable RF signal that is tunable in 1 MHz steps from at least 100 MHz to 200 MHz. The signal generator should also have AM, FM and (if available) Φ M capability at a 1 kHz rate.

And You

If you are now sitting comfortably in front of your HP 8902A, you are ready to begin. Start on the next page and follow the step-by-step guide to learning to operate the HP 8902A. You will soon discover how the HP 8902A can increase both the ease and speed of many of your measurements.



Note

If you plan to selectively refer to portions of Chapter 1, rather than perform all of the procedures in sequence, we recommend that you complete the procedures in the Frequency Counter portion of this chapter first. The Frequency Counter portion contains an introduction to the tuning and reset capabilities that are important to all of the HP 8902A's measurements.

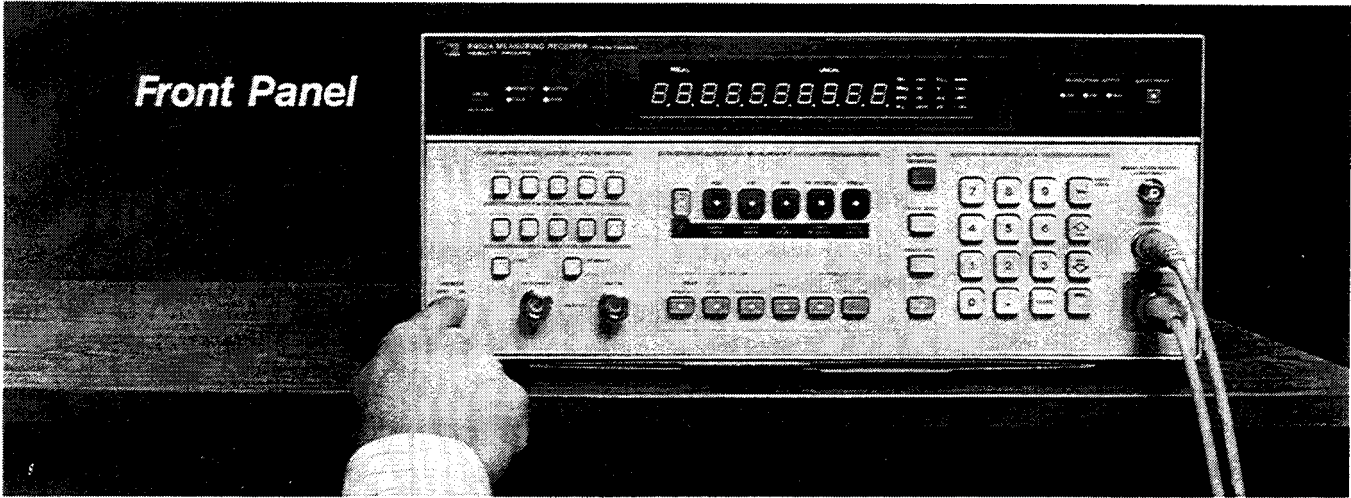

1. **Take a look at the HP 8902A's Front Panel.** Notice that label brackets have been placed over each key group to help you quickly find the function desired.
2. **Note the gold and blue keys.** These keys will enable you to select the "shifted" functions. As this guide will demonstrate, the shifted functions are selected by pressing the gold or blue key and then the desired function key.
3. **Switch the HP 8902A from STBY to ON.** Notice that as the HP 8902A powers up, it performs a self-test that includes turning on all front panel lights.

The Display

The HP 8902A keeps you informed of its operating status by the dashes and error codes it places in its display.

Interpreting the Dashes

4. **Adjust your signal generator to -40 dBm.** This causes the HP 8902A to place two dashes in its display. Two dashes indicate that the level of the input signal is too low for the instrument to detect in its current measurement mode.
5. **Set the signal generator to 0.0 dBm.** Once the HP 8902A detects an input signal, it removes the two dashes from its display. Sometimes you will see the HP 8902A replace the two dashes with four dashes. Four dashes indicate that the instrument is involved in internally setting up the measurement. If the HP 8902A displays four dashes for more than a few seconds, the instrument may be having difficulty tuning to an unstable input signal. (The HP 8902A's Track Mode tuning, described later in this chapter, is typically a good choice for tuning to unstable signals.)

--	Input signal not sensed
----	HP 8902A setting up measurement

Interpreting Error Codes

6. **Press the CALIBRATE key.** (See the adjacent instrument diagram for the key location.) The HP 8902A will display Error 21 to inform you that you have attempted to select an operating condition that is not compatible with the measurement you are making. Error codes like this will keep you informed of both operator errors and input signal problems. The reference chapters (2, 3, and 4) list the error codes that can be encountered for each measurement along with recommended recovery actions.

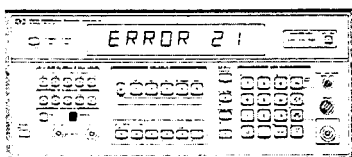

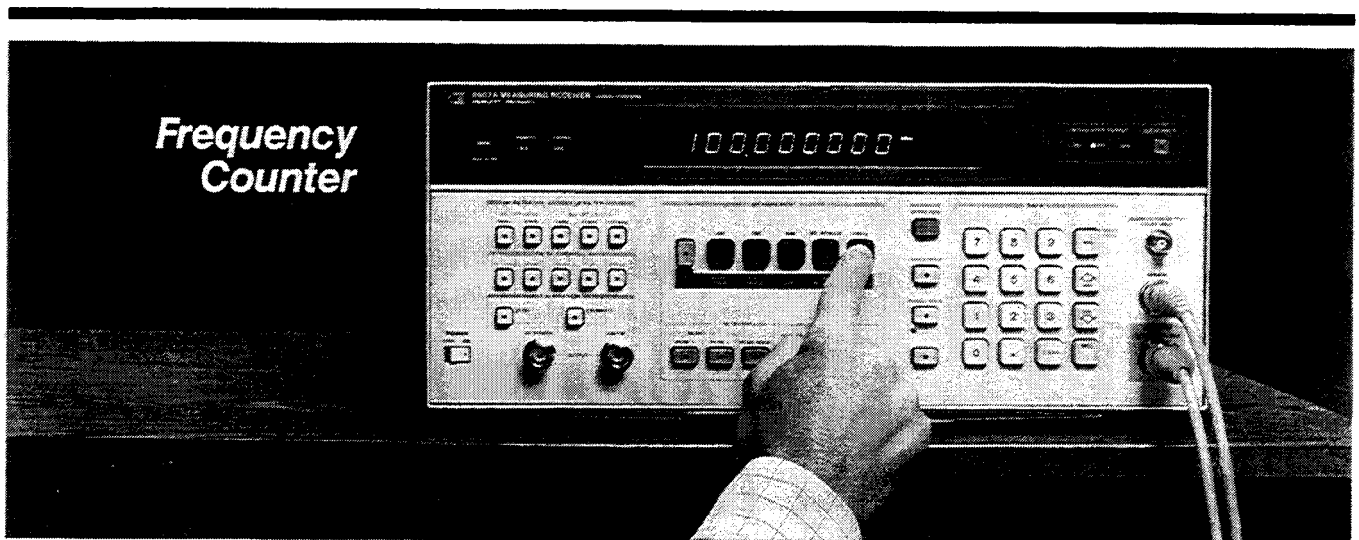

When your signal source testing requires an accurate RF frequency counter, the HP 8902A is a convenient solution. The HP 8902A makes it easy to tune to and measure the frequency of complex modulated signals.

If you haven't setup your HP 8902A, Sensor Module, and signal generator as shown in Diagram 1-1 (page 1-2) you will need to do so in order to perform the following procedures.

Adjust Your Signal Generator

RF Frequency 100 MHz
 Frequency Increment 1 MHz
 Amplitude 0.0 dBm
 Modulation Off

Measuring RF Frequency

1. Press the **FREQ** key and the green **AUTOMATIC OPERATION** key on the HP 8902A. That's all it takes to configure the HP 8902A as an RF counter. Notice that the HP 8902A automatically tunes to and displays the frequency of the input signal (approximately 100 MHz; the absolute value depends on the accuracy of your signal generator and the accuracy of the HP 8902A's time base reference.) Note also that **AUTO TUNING** (the green LED on the front panel) is on. This LED lets you know that the instrument is in its automatic tuning mode.

1 Hz Resolution

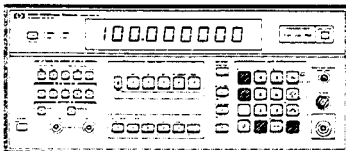

2. To increase the HP 8902A's display resolution to 1 Hz, key in **7.4 SPCL** * by pressing the digit keys **7 • 4** and the **SPCL** key (see the adjacent instrument diagram for key locations). If you enter a wrong digit, simply press the **CLEAR** key and begin again. Note that the **SPCL** key remains lit to show that a special function has been manually set.

* If the HP 8902A displays Error 23 when you enter 7.4 SPCL, it is not equipped to provide 1 Hz counter resolution. Enter 7.1 SPCL instead to select 10 Hz display resolution.

Measurement Ranges

That's all it takes to make an accurate frequency count on a stable signal throughout the following ranges:

Input Frequency	Amplitude Range
150 kHz to 650 MHz	+30 to -25 dBm
650 MHz to 1300 MHz	+30 to -20 dBm

Choosing a Tuning Mode

Proper tuning is the key to making successful RF Frequency as well as other tuned measurements with the HP 8902A. The optimum tuning mode for your measurement will depend on the characteristics of the input signal.

3. **Adjust your signal generator to 110 MHz.** The HP 8902A should automatically tune to the new input signal. (Note that four dashes are placed in the display while the HP 8902A is tuning to the input signal.)

Manual Tuning Mode

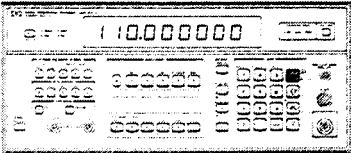

4. **Key 110 MHz into the HP 8902A by pressing the digit keys 1 1 0 and the MHz key.** Note that AUTO TUNING (the green LED) is now off. By keying in an RF frequency and pressing the MHz key, you have selected the instrument's Manual Tuning mode. The HP 8902A's tuning is now set at 110 MHz.

The Manual Tuning mode can also be selected by pressing the MHz key by itself. When you press the MHz key without keying in a frequency value, the HP 8902A's tuning is set at the frequency currently being displayed.

5. **Adjust your signal generator to 112 MHz.** The HP 8902A will display an Error 01 to let you know that the input signal is no longer within the tuning range of the frequency (110 MHz) that the instrument was manually set to.

Auto Tuning Mode

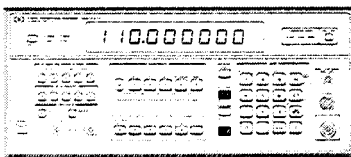

6. **Press the Blue Shift key and the AUTO TUNING (TRACK MODE) key.** You have placed the instrument back in its Auto Tuning mode. (Notice that the AUTO TUNING, green LED is on again.) The HP 8902A is now tuned to the frequency of the input signal. (The Auto Tuning mode is the right choice when measuring a single, stable input signal.)

Track Mode

7. **Press the TRACK MODE key.** In Track Mode, the HP 8902A is locked to the input signal.

8. Increment your signal generator from 112 MHz to 100 MHz in 1 MHz steps. The HP 8902A is now able to track the input signal as it changes frequency. (Track Mode is the right choice when you are measuring a drifting or noisy signal.)

Measurement Selected	Input Condition	Tuning Mode to Select	HP 8902A Operation
RF Frequency, Modulation, or Audio	Single, stable signal	Auto Tuning	Tuned to frequency of input signal
	Multiple, stable signals	Manual Tuning	Tuning set at manually tuned frequency
	Single, drifty or noisy signal > 10 MHz	Auto Tuning Track Mode	Tuning locked to input signal
	Multiple, drifty or noisy signals > 10 MHz	Manual Tuning Track Mode	Tuning locked to input signal
Frequency Error, RF Power, or Tuned RF Level	All Cases	Manual Tuning	Tuning set at manually tuned frequency

Measuring Frequency Error

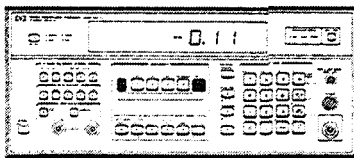

The HP 8902A makes checking RF frequency error a simple two-step process. Adjust your signal generator to 100 MHz.

1. Key 100 MHz into the HP 8902A to manually tune it to the frequency of your signal generator (100 MHz).
2. Press the gold S key, and then the FREQ ERROR (FREQ) key (both keys should remain lit). The HP 8902A is now displaying the frequency difference (in kHz) between the manually tuned frequency (100 MHz) and the actual output frequency of your signal generator. (Note that the instrument displays a negative difference when the input frequency is less than the HP 8902A's manual setting and a positive difference when the input frequency is greater.)

Remember



Manual tuning is always the right choice when measuring Frequency Error because it establishes a known frequency reference. Also, the Frequency Error measurement should only be made on a stable input signal.

That's all it takes to make Frequency Error measurements with the HP 8902A.

10 Hz Resolution

3. To display 10 Hz counter resolution, enter 7.1 SPCL by pressing the digit keys 7 • 1 and the SPCL key. Note that the SPCL key remains lit to indicate that a special function has been invoked.

Reset

The HP 8902A provides you with two ways to return its operating functions to their automatic operating condition. The following procedures demonstrate the two reset functions.

Automatic Operation

4. Press the green **AUTOMATIC OPERATION** key. You have placed the instrument back in its Auto Tuning mode (green LED on) and you have disabled Special Function 7.1 (SPCL key no longer lit). Pressing the **AUTOMATIC OPERATION** key resets Special Functions 1 through 10 to their Automatic Operation condition and returns the instrument to its Auto Tuning mode (not the best choice for Frequency Error measurements, remember). Note that the instrument is still in the Frequency Error measurement mode (gold S key lit).

Instrument Preset

5. Now press the Blue Shift key and then the green **INSTR PRESET (AUTOMATIC OPERATION)** key. Note that the instrument is reset to the Frequency measurement mode (gold S key off). **INSTR PRESET** resets the entire instrument to its power-up default condition.

Key	Function	Contribution
AUTOMATIC OPERATION	<ol style="list-style-type: none"> 1. Selects Auto Tuning Mode. 2. Resets special functions 1 through 10 to their Automatic Operation condition. 	Provides operator error recovery by resetting the operating functions that can cause an error condition.
INSTR PRESET	Resets <i>all</i> operating functions.	Sets all operating functions to their defined power-up condition.



To Learn More...

Chapter 2 in this guide provides reference information about the RF Frequency and Frequency Error measurements and the HP 8902A's tuning capabilities. Refer to *Chapter 2* when you want to find out more about:

- **Tuning Modes** - Further information about the HP 8902A's tuning modes.
- **Extending Operation** - The special operating capabilities that enable you to adapt the RF Frequency and Frequency Error measurements to the specific conditions of your input signal.
- **Help** - Solutions to setup or operating problems encountered when making RF Frequency or Frequency Error measurements.

Refer to *Chapter 5* for examples of RF Frequency measurement applications.

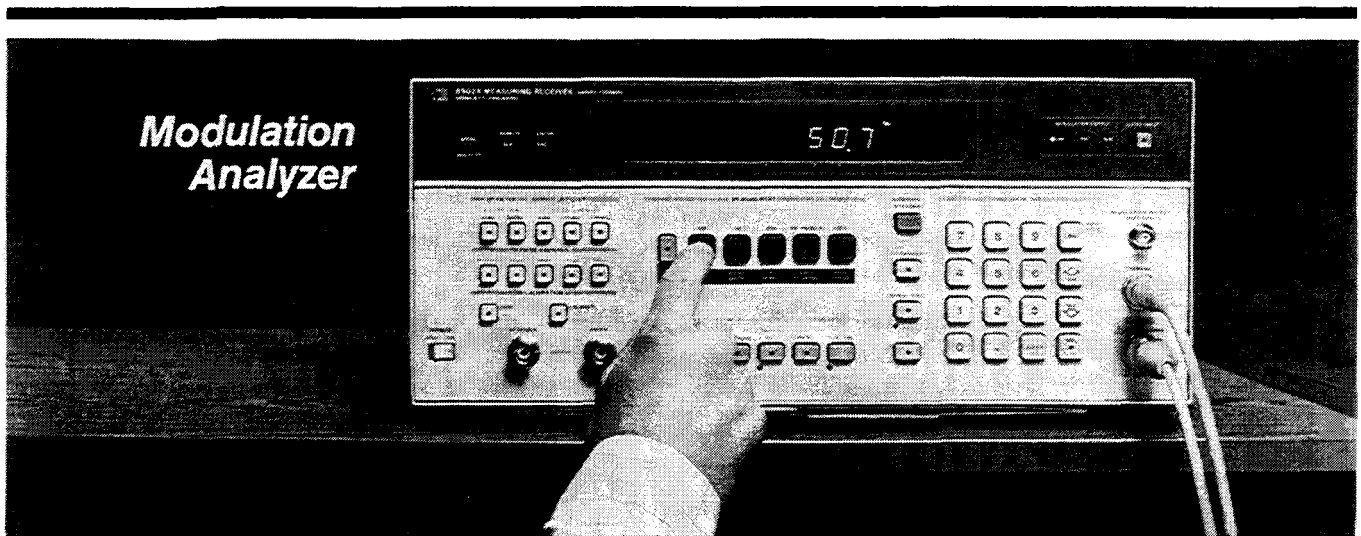

The HP 8902A offers complete modulation analyzer capability to meet your AM, FM and Φ M measurement needs. Even difficult measurements such as signal-to-noise and incidental AM and FM can be made with ease and superb accuracy using the HP 8902A.

Set up your HP 8902A, Sensor Module, and signal generator as shown in Diagram 1-1.

Adjust Your Signal Generator

RF Frequency 100 MHz
 Amplitude 0.0 dBm
 Modulation AM
 Depth 50%
 Rate 1 kHz

Measuring AM

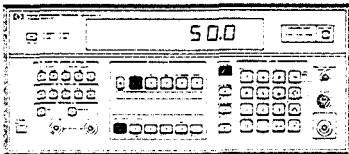

1. Press the **AM** key, the green **AUTOMATIC OPERATION** key, and the **PEAK+** detector key. The instrument should display an AM index of approximately 50%. Notice that the instrument is in the Auto Tuning mode (green **AUTO TUNING** LED on). The HP 8902A automatically found and tuned to the modulated RF signal. (The Auto Tuning mode is a good choice for making most modulation and audio measurements.)
2. Key in 100 MHz by pressing the digit keys **1 0 0** and the **MHz** key. The instrument is now manually tuned to the frequency of the input signal (green LED off). (Manual Tuning is a good choice when measuring modulation in the presence of multiple RF input signals.)

Selecting a Detector

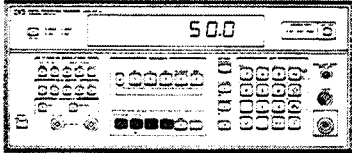

The HP 8902A provides six detector functions for measuring your modulation and audio signals.

Peak Detector

3. Press the **PEAK-** key. Switching between the Peak+ and Peak- detector allows you to check modulation symmetry.
4. Press both the **PEAK+** and **PEAK-** keys at the same time. Pressing both detector keys at the same time allows you to display the average value of the positive and negative peak readings. (PEAK $\pm/2$).
5. Press the **PEAK+** key and then the **PEAK HOLD** key. The Peak Hold detector captures and holds the peak modulation level detected by the Peak+ or Peak- detector.
6. Increase the modulation depth of the signal generator to 75% and then reduce it back to 50%. Notice that the HP 8902A continues to display the maximum modulation level. The Peak Hold detector is ideal for detecting short modulation transients.

Average Detector

7. Now press the **AVG** key to select the average-responding detector. You have selected an average responding detector that is calibrated to read the rms value of a sinewave. The HP 8902A should be displaying approximately 35% AM with the signal generator set at 50% AM.

RMS Detector

8. Press the **Blue Shift** key and then the **RMS (AVG)** key (the red LED below the RMS key will come on). You have now selected a true-RMS detector. The Average detector and the RMS detector are good choices when measuring noise or residual modulation where the rms value is generally more desirable than the peak value. The true-RMS detector can be used to measure modulation rates up to 40 kHz and provides one more digit of resolution than the Average Detector. The true-RMS detector is also a good choice for measuring non-sinusoidal signals.

AM Measurement Ranges

Simply select AM and any of the above detector functions to make AM measurements within the following ranges:

RF Carrier Frequency	Modulation Rate	Max. Depth
150 kHz to 9.999999 MHz	20 Hz to 10 kHz	99%
10 MHz to 1300 MHz	20 Hz to 100 kHz	

Measuring FM

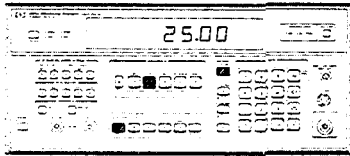

1. Turn off AM on the signal generator and turn on 25 kHz of FM deviation at a 1 kHz rate.
2. Press the FM key, the green **AUTOMATIC OPERATION** key, and the **PEAK+** detector key. The HP 8902A should display a reading of about 25 kHz. Notice that in the upper right corner of the instrument the yellow FM MODULATION OUTPUT LED is lit. This indicates that the demodulated FM signal is available at the front-panel MODULATION OUTPUT/AUDIO INPUT port. (Connecting another audio analyzer to this port will enable you to make audio measurements on the demodulated signal while monitoring modulation with the HP 8902A.)

Measuring Pre-Emphasized FM

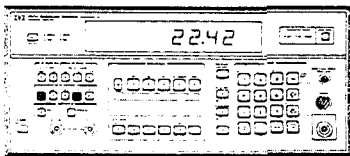

- To accommodate your pre-emphasized FM signals, the HP 8902A is equipped with four separate de-emphasis filters. (Each FM DE-EMPHASIS key is labeled with a time constant corresponding to the 3 dB corner frequency of that de-emphasis filter.)
3. Press the **75 μ s FM DE-EMPHASIS** key (if the **PRE-DISPLAY** key is not lit, press it too). The display now shows the level of the demodulated signal after it has been de-emphasized. (The de-emphasized FM signal is now available at the front-panel MODULATION OUTPUT/AUDIO INPUT port.)
 4. Press the **PRE-DISPLAY** key again to turn Pre-Display off. Notice that the display now shows the level of the demodulated FM signal before it is de-emphasized. The demodulated signal is now being applied to the de-emphasis filter after it is measured by the HP 8902A. (The de-emphasized signal is still present at the MODULATION OUTPUT/AUDIO INPUT port, however.)
 5. Press the **75 μ s** key again to turn off the FM De-emphasis function. Repeat step 3 to select any of the four de-emphasis filters.

Inserting Audio Filters

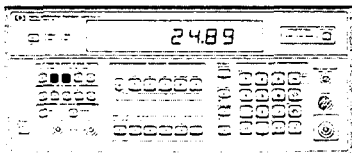

- To remove undesired signals such as harmonics, noise, and spurs from the demodulated signal, insert the selectable high-pass and low-pass audio filters when making modulation or audio measurements. To minimize overshoot from square-wave modulation, such as frequency shift keying (FSK), select the >20 kHz Bessel Filter.
6. Press the **300 Hz** key and the **3 kHz** key to set a typical measurement bandwidth of 300 Hz to 3 kHz. Diagram 1-2 shows the typical frequency response of each audio filter.

7. Press the 300 Hz key and the 3 kHz key again to remove these filters.

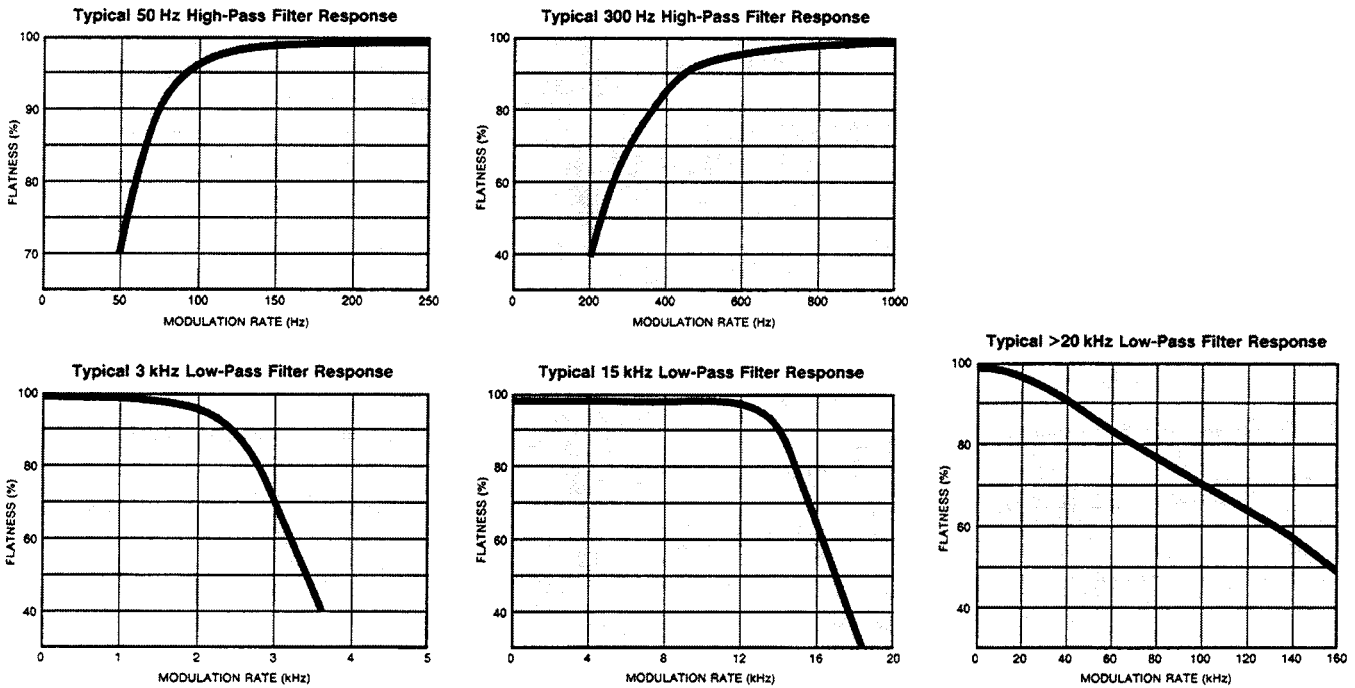

Diagram 1-2. The typical frequency response of each Audio Filter

FM Measurement Ranges

That's all it takes to make FM measurements and select audio filters throughout the following ranges:

RF Carrier Frequency	Modulation Rates	Max. Deviation
150 kHz to 9.9999 MHz	20 Hz to 10 kHz	40 kHz peak
10 MHz to 1300 MHz	20 Hz to 200 kHz	400 kHz peak

Measuring ϕM

1. Turn off the FM on the signal generator and select 10 radians phase modulation at the rate of 1 kHz. (If your signal generator does not have ΦM capability, set modulation to FM, 10 kHz deviation at a 1 kHz rate.)

In Radians

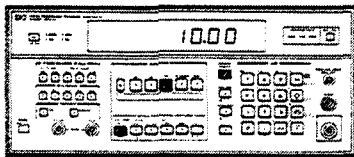

2. Press the ΦM key, the green **AUTOMATIC OPERATION** key, and the **PEAK+** detector key. The HP 8902A should display a reading of about 10 radians. Notice that the yellow ΦM MODULATION OUTPUT LED is now lit to indicate that the demodulated ΦM signal is available at the MODULATION OUTPUT/AUDIO INPUT port. (An audio measurement device, such as an oscilloscope, can be connected to this port for monitoring the demodulated audio signal.)

In Degrees

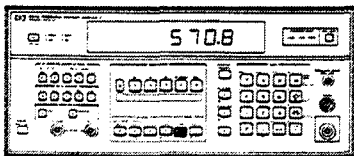

3. Key in 1.745 and then press the **RATIO** key. The HP 8902A is now displaying the phase deviation in degrees. (If the display is reading in dB, press the LOG/LIN key to get %. The instrument should display approximately 570 degrees for 10 radians of ΦM .)

ϕM Measurement Ranges

Select the ΦM measurement mode to simplify your phase modulation measurements throughout the following ranges:

RF Carrier Frequency	Modulation Rates
150 kHz to 9.999999 MHz	200 Hz to 10 kHz
10 MHz to 1300 MHz	200 Hz to 20 kHz

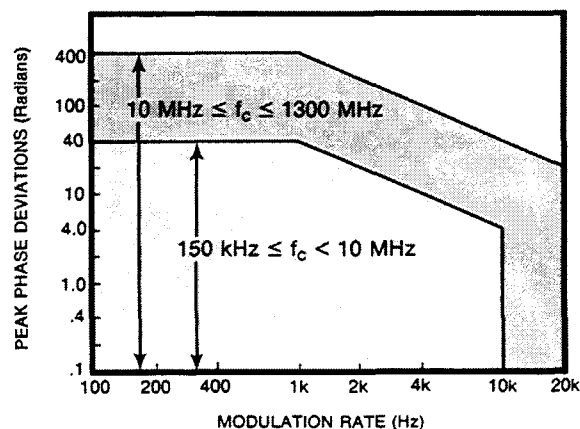



To Learn More...

Chapter 3 in this guide provides additional information about the modulation measurements. Refer to *Chapter 3* when you want to find out more about:

- **Calibration** - The procedure to calibrate your AM and FM measurements.
- **Extending Operation** - The special operating capabilities that enable you to adapt the Modulation measurements to the specific conditions of your input signal.
- **Help** - Solutions to setup and operating problems encountered when making modulation measurements.

Refer to *Chapter 5* for examples of modulation measurement applications.

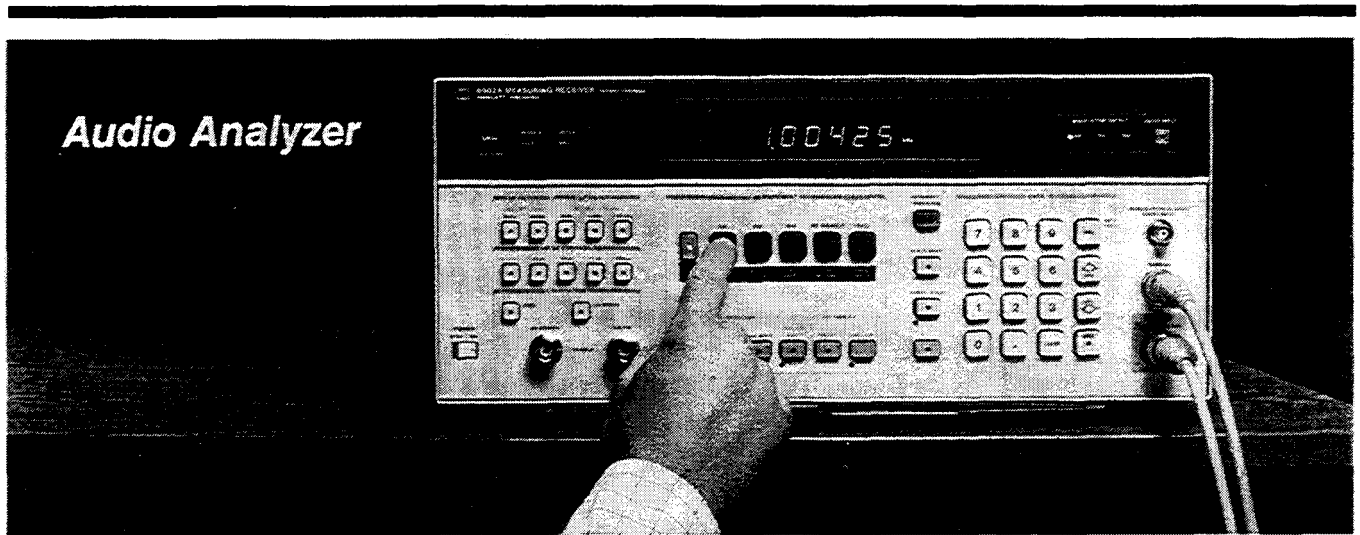

The HP 8902A enables you to measure your audio signal sources as well as your RF signal sources. Use the HP 8902A to make audio frequency, distortion, and level measurements.

Set up your HP 8902A, Sensor Module, and signal generator as shown in Diagram 1-1.

Adjust Your Signal Generator

RF Frequency 100 MHz
 Amplitude 0.0 dBm
 Modulation AM
 Depth 50%
 Rate 1 kHz

Measuring Audio Frequency

The HP 8902A enables you to accurately count the frequency of the internally-demodulated audio signal or of an external audio signal connected to the MODULATION OUTPUT/AUDIO INPUT port.

Demodulated Audio

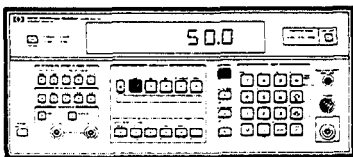

1. Press the **AM** key and then the green **AUTOMATIC OPERATION** key. Entering the AM measurement mode first, selects the AM demodulator for measuring the AM input signal. The HP 8902A uses the last demodulator selected before entering an audio measurement mode to make its audio measurements. (Notice that the yellow AM MODULATION OUTPUT LED is lit. When you are making audio measurements, the MODULATION OUTPUT LEDs will show you which demodulator is selected.)

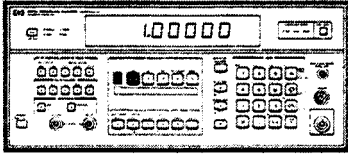

2. Press the gold **S** key and then **AUDIO FREQ (AM)** key (both keys should remain lit). The HP 8902A is now displaying the frequency of the demodulated audio signal (approximately 1 kHz). The demodulated audio signal is also available at the front-panel **MODULATION OUTPUT/AUDIO INPUT** port.

External Audio

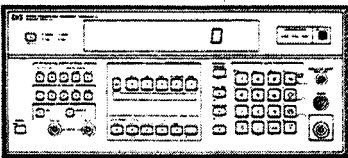

3. Press the **AUDIO INPUT** key (key lit) to convert the **MODULATION OUTPUT** port to an **AUDIO INPUT** port. The HP 8902A is now able to make its audio measurements on an external audio signal source connected to the **AUDIO INPUT** port. Press the **AUDIO INPUT** key again to convert the port back to a modulation output and continue measuring the internally demodulated audio signal.

Audio Frequency Measurement Ranges

That's all it takes to measure internally-demodulated or external audio frequencies throughout the following ranges:

Audio Frequency	Max. External Input Voltage
20 Hz to 250 kHz (usable to 600 kHz)	3 Vrms

Measuring Audio Distortion

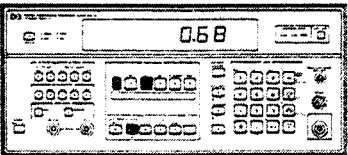

Use the HP 8902A to measure distortion on either a 400 Hz or a 1 kHz signal. Distortion measurements can be made on either the internally demodulated signal or on an external audio signal connected to the **AUDIO INPUT** port.

1. Press the gold **S** key and the **AUDIO DISTN (FM)** key (both keys should remain lit). The instrument is now displaying the measured distortion of the 1 kHz demodulated signal. Notice that in the display, the 1 kHz annunciator is lit. The true-RMS detector is used to make this measurement.
2. Press the **Blue Shift** key and the **400 Hz DISTN (PEAK-)** key (the 400 Hz annunciator should be lit in the display). The instrument is now ready to measure the distortion level of a 400 Hz signal.

Audio Distortion Measurement Ranges

That's all it takes to measure audio distortion throughout the following measurement ranges:

Audio Frequency	Max. External Input Voltage	Display Range
400 Hz and 1 kHz	3 Vrms	0.01% (-80.0 dB) to 100.0% (0.00 dB)

Measuring Audio Level

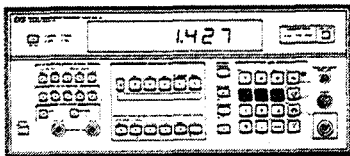

The HP 8902A is able to measure the rms voltage level of external audio signals applied directly to the AUDIO INPUT port. (Audio level measurements cannot be made on internally demodulated signals.)

1. **When you need to measure audio level, connect an audio source to the AUDIO INPUT port.**
2. **Key in 30.0 SPCL.** The instrument will display the rms voltage level of the input signal. (Press the Blue Shift key and the voltage unit keys μV (4), mV (5), or Volts (6) to select the desired voltage units.)
3. **Press any measurement function key to exit the Audio Level measurement mode.**

Audio Level Measurement Ranges

That's all it takes to measure audio level throughout the following ranges:

Audio Frequency	Input Voltage
50 Hz to 40 kHz	100 mV to 3V



To Learn More...

Chapter 3 in this guide provides additional information about the HP 8902A Audio measurement capabilities. Refer to *Chapter 3* when you want to know more about:

- **Extending Operation** - The special operating capabilities that enable you to adapt the Audio measurements to the specific conditions of your input signal.
- **Help** - Solutions to setup and operating problems encountered when making Audio measurements.

Refer to *Chapter 5* for examples of Audio measurement applications.



The HP 8902A provides you with the capability and accuracy of the best power meters. With a single keystroke, the HP 8902A autoranges to the input signal, measures its power, compensates for power sensor flatness, and displays the results in the units of your choice.

Adjust Your Signal Generator

RF Frequency 100 MHz
 Amplitude 0.0 dBm
 Modulation Off

RF Power Calibration

Like all power meters, the HP 8902A must first be calibrated. An internal RF Power Calibrator enables you to calibrate the Sensor Module and the HP 8902A's Power Meter to an internal 50 MHz, 1.00 mW reference signal. The following calibration procedure must be performed only one time to calibrate your Sensor Module. This means you do not need to perform this procedure again as long as you are using the same Sensor Module. To ensure the highest possible measurement accuracy, allow the HP 8902A to warm up for at least thirty minutes before performing the calibration procedure.

1. Press the **RF POWER** key on your HP 8902A.

Error 15

If the HP 8902A is displaying Error 15, it has not yet been configured to make RF Power measurements. (Refer to *Appendix B* and perform the Calibration Factor Entry procedure before going on with this procedure.)



Note

The calibration factors for the Sensor Module you are using must be stored in the HP 8902A in order for it to make calibrated, automatic RF Power measurements. If you are not certain that the correct calibration factors are stored in the instrument, refer to Appendix B.

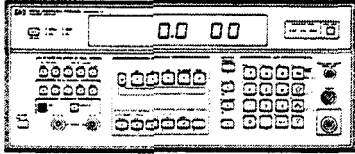

2. Connect the HP 11722A Sensor Module to the RF POWER OUTPUT port on the HP 8902A. This port outputs the 1.00 mW reference signal. (Disregard Error 11 when it is displayed.)
3. Press the ZERO key. Wait approximately 8 seconds for the zeroed sensor reading to be displayed briefly. The HP 8902A is correcting for any dc offset error inherent within the measurement system.

Remember



As a good rule of thumb, press the ZERO key approximately every 10 minutes when making RF Power or Tuned RF Level measurements to compensate for any changes in the ambient operating conditions. The zeroing process is most effective if the ZERO key is pressed with the HP 11722A Sensor Module connected to the signal source being measured.

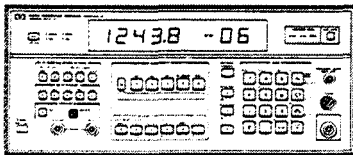

4. Press the CALIBRATE key. Wait for a stable, calibrated reference reading to be displayed. The HP 8902A is creating a correction factor that enables the instrument to equate its power measurement reading to the 1.00 mW reference.
5. Press the Blue Shift key and then the SAVE CAL (CALIBRATE) key. This stores the calibrated reference in the instruments non-volatile memory.
6. Press the CALIBRATE key again. This turns off the calibrator. You have completed the calibration procedure.
7. Connect the Sensor Module to the signal generator. The HP 8902A is now calibrated to make accurate power measurements with the Sensor Module you are using. From now on, you need only repeat step 2 to maintain RF Power calibration.

Measuring RF Power

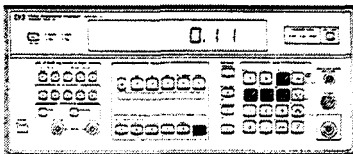

1. Press the RF POWER key. The instrument should read approximately 1000 -06W (1000 μ W) with the signal generator set to 0.0 dBm.
2. Press the LOG/LIN key to toggle the display reading between logarithmic (dBm) and linear (watts) units. The instrument also converts measurement readings to voltage units when you select the Blue Shift key and a voltage units key such as μ V (4), mV (5), or V (6). Press the Blue Shift key and then the WATTS (9) key to exit the voltage units mode.
3. Adjust the frequency of the signal generator to 119 MHz.

Changing Frequency

Manual Tuning

Key the new output frequency of the signal generator into the HP 8902A by pressing the digit keys 1 1 9 and then the MHz key. The HP 8902A must be set to the same frequency as the input signal to enable the instrument to select the correct calibration factor.

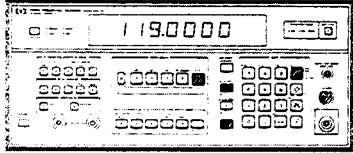

Remember



If the frequency of the input signal changes, always change the frequency setting of the HP 8902A as well.

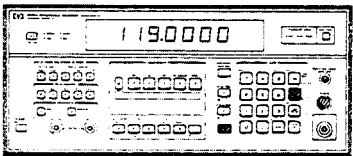

RF Power Measurement Ranges

From now on, simply select RF Power to make accurate, calibrated RF Power measurements throughout the following ranges using an HP 11722A Sensor Module:

Input Frequency	Input Amplitude
100 kHz to 2.6 GHz (HP 11722A)	-20 dBm (10 μ W) to +30 dBm (1 W)

To Learn More...



Chapter 4 in this guide provides information about the HP 8902A's additional capabilities when in the RF Power mode. Refer to Chapter 4 when you want to find out more about:

- **Calibration** - The RF Power calibration technique.
- **Extending Operation** - The special operating capabilities that enable you to adapt the RF Power measurement to the specific conditions of your input signal.
- **Help** - Solutions to setup or operating problems when making RF Power measurements.

Refer to Chapter 5 for examples of RF Power measurement applications.

- Auto Tuning**
5. You can also allow the HP 8902A to automatically tune to the new input frequency, by pressing the **FREQ** key, the **Blue Shift** key, and the **AUTO TUNING (TRACK MODE)** key. After the HP 8902A displays the new input frequency, press the **MHZ** key and then the **RF POWER** key to re-enter the RF Power measurement mode.

6. To verify that the frequency setting of the HP 8902A is the same as the frequency of the signal generator, press the **Blue Shift** key and then the **DISP FREQ (kHz \uparrow)** key. You can use this method to check frequency tuning when in any of the measurement modes.

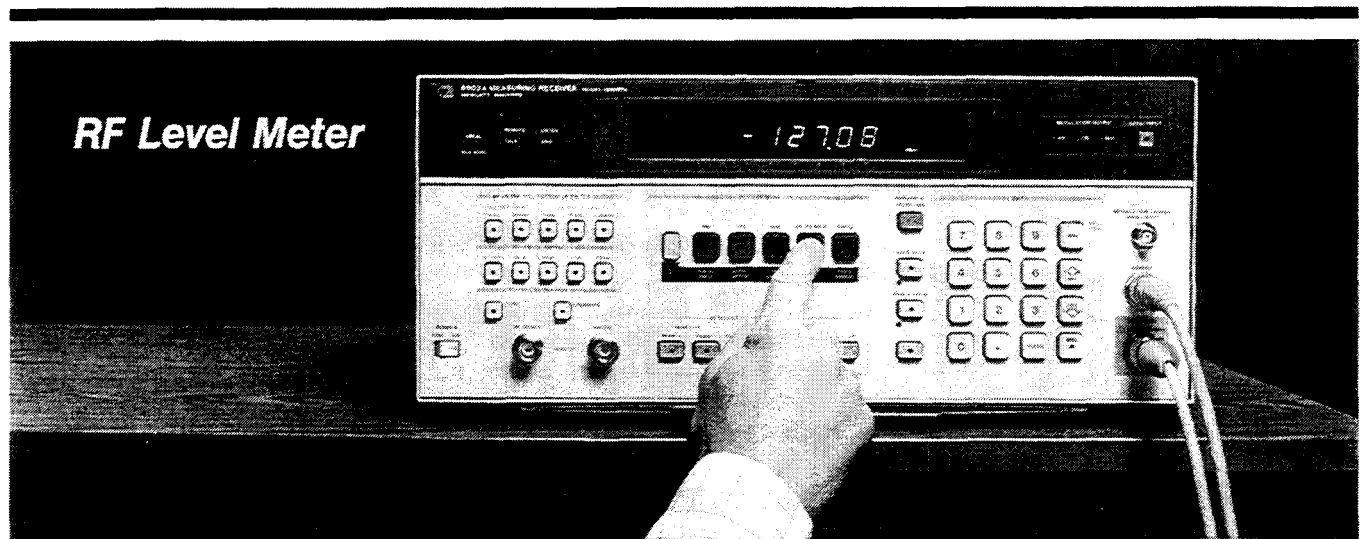

The HP 8902A offers unprecedented low-level measurement capability. Select the Tuned RF Level measurement to make precise, narrowband RF level measurements down to -127 dBm. The Tuned RF Level measurement is an excellent choice for performing low-level accuracy tests.

Set up your HP 8902A, Sensor Module, and signal generator as shown in Diagram 1-1.

Adjust Your Signal Generator

RF Frequency 119 MHz
 Amplitude 0.0 dBm
 Amplitude Increment 10 dB
 Modulation Off

Tuned RF Level Calibration

To make accurate low-level measurements down to -127 dBm, the HP 8902A uses a precise, IF signal substitution technique. This technique creates three RF measurement ranges within the full measurement range of the tuned RF Level measurement (0 to -127 dBm). Tuned RF Level calibration involves the creation of a calibration factor for each of the three ranges at the tuned frequency. The following simple procedure creates these calibration factors. (More information about the calibration technique is provided in *Chapter 4*.)

1. Press the **FREQ** key and then the green **AUTOMATIC OPERATION** key on the HP 8902A. This tunes the HP 8902A to the input signal. When the HP 8902A displays the input frequency, press the MHz key (to select Manual Tuning), the gold S key, and then the **TUNED RF LEVEL (RF POWER)** key. (Both the gold S key and the **TUNED RF LEVEL** key should remain lit.) You may see the HP 8902A place six dashes in its display prior to displaying the measurement reading. The instrument displays six dashes only when in the TRFL measurement mode. Six dashes indicate that the HP 8902A is searching for an input signal at the frequency that it has been tuned to.

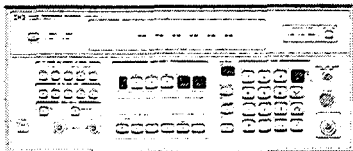

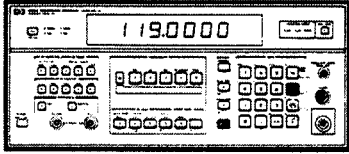

2. Press the **Blue Shift** key and the **DISPLAY FREQ (kHz ↑)** key to check that the HP 8902A is tuned to the output frequency of the signal generator (119 MHz). If it is not, manually tune it by keying in 119 MHz. (Manual Tuning is the right choice for TRFL measurements.)
3. Both the **RECAL** and the **UNCAL** annunciators should be lit in the display. The **UNCAL** annunciator indicates that the displayed reading is not yet calibrated. The **RECAL** annunciator indicates that calibration is possible at the current input signal level. (If the HP 8902A has already been calibrated at 119 MHz, the annunciators will not be lit. You can enter 39.9 SPCL to clear the calibration factors for 119 MHz so that you can continue with this demonstration.)

Range 1

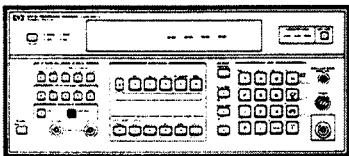

4. Press the **CALIBRATE** key. After the instrument completes the calibration process, both annunciators will go out. You have just calibrated Range 1 (0 to -40 dBm). (No further calibration is required to accurately measure input levels within this range.)

Note



It is very important that the level of the input signal remain stable during the calibration process (while the CALIBRATE key is lit).

5. Press the **LOG/LIN** key to select either linear (Watts) or logarithmic (dBm) units.
6. Decrement the signal generator level in 10 dB steps down to -40 dBm. Note that neither the **RECAL** or **UNCAL** annunciator is lit until you get to -40 dBm. This means that each of the displayed readings down to -40 dBm is a fully calibrated measurement.
7. At -40 dBm, the instrument displays the **RECAL** annunciator again. The **RECAL** annunciator indicates that the HP 8902A needs to be recalibrated now in order to make accurate level measurements within its next RF measurement range (approximately -40 to -80 dBm). Note that the **UNCAL** annunciator is not displayed. This means that the displayed reading is still a fully calibrated measurement.

Range 2

8. Press the **CALIBRATE** key. After the instrument completes the TRFL calibration, the **RECAL** annunciator will go out. You have now calibrated Range 2 (-40 to -80 dBm).
9. Continue decrementing the signal generator to -80 dBm. The **RECAL** annunciator will be displayed again.

Range 3

10. Press the **CALIBRATE** key again to calibrate Range 3. The instrument is now calibrated to make level measurements (at 119 MHz) over its entire measurement range (0 to -127 dBm).

You can now adjust the output level of the signal generator to any level between 0 and -127 dBm and no further calibration will be needed to measure the 119 MHz signal.

Measuring Tuned RF Level

The following information is provided to help you quickly complete your Tuned RF Level measurements.

Changing Frequency

Achieving the accuracy of the Tuned RF Level (TRFL) measurement requires that the calibration procedure be repeated at each frequency to be measured. The following chart will help you remember the key steps to performing TRFL measurements.

Key Steps	Considerations
1. Set the level of your signal source to between 0 and -20 dBm (0 dBm is optimum).	The three RF measurement ranges must be calibrated sequentially beginning with the first range Range 1 0 dBm Range 2 -40 dBm Range 3 -80 dBm
2. Tune the HP 8902A to the frequency of your signal source.	Manually: Key in the frequency and press the MHz key, or Automatically: Press the FREQUENCY key and select Auto Tuning. After the frequency is displayed, press the MHz key to select Manual Tuning and then re-enter the TRFL measurement mode.
3. Press the CALIBRATE key each time the RECAL annunciator lights.	The RECAL annunciator will only appear three times for each frequency (once for each measurement range). Remember not to change the input signal level during calibration (while the CALIBRATE key is lit).

RECAL UNCAL

The UNCAL annunciator indicates that the currently displayed measurement is uncalibrated. The HP 8902A displays the UNCAL annunciator when a change in the frequency or level of the input signal requires the instrument to use an RF measurement range that is not yet calibrated. The RECAL annunciator is displayed when the input signal is at a level where it can be used to calibrate the next (uncalibrated), RF measurement range. The following chart will help you to quickly interpret these annunciators.

RECAL	UNCAL	Description	Action
OFF	OFF	The displayed measurement is calibrated.	No action is required unless the RECAL or UNCAL annunciator is lit.
ON	OFF	The displayed measurement is calibrated, and calibration of the next measurement range is possible.	Press the CALIBRATE key to calibrate the next RF measurement range.
ON	ON	The displayed measurement is uncalibrated, but calibration is possible.	Press the CALIBRATE key to calibrate the RF measurement range you are in.
OFF	ON	The displayed measurement is uncalibrated, but calibration is not possible at the current input level.	Perform steps 1 through 3 in the chart above to calibrate each RF range. (Note the range calibration levels specified in step 1 under "Considerations".)

Tuned RF Level Measurement Ranges

That's all it takes to make accurate Tuned RF Level measurements throughout the following frequency and level ranges using an HP 11722A Sensor Module:

Frequency	Level
2.5 MHz to 1300 MHz	0 dBm to -127 dBm



To Learn More...

Chapter 4 in this guide provides additional information about the TRFL measurement and the extended capabilities that will help you adapt the measurement to your needs. Refer to *Chapter 4* when you want to find out more about:

- **Calibration** - Understanding the TRFL calibration technique.
- **Extending Operation** - The special operating capabilities that enable you to adapt the TRFL measurement to the specific conditions of your input signal.
- **Help** - Solutions to setup and operating problems encountered when making TRFL measurements.

Refer to *Chapter 5* for examples of Tuned RF Level measurement applications.

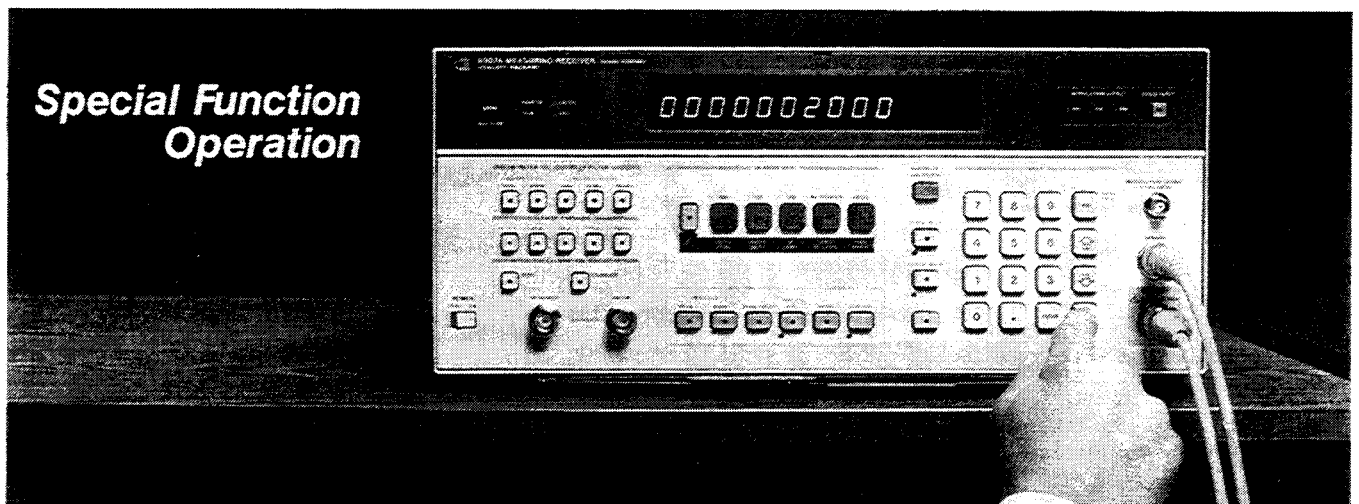

Most measurements made with the HP 8902A require only a keystroke to invoke. There is no need to adjust levels, or select ranges because the HP 8902A's microprocessor determines the optimum instrument settings automatically. However, in some applications it is desirable to override the automatic selection. Special functions provide you with manual control of instrument operation, selection of additional measurement modes, and the ability to extend measurement ranges. The HP 8902A's special functions are described in the following chart.

Capability	Codes	Application
To extend instrument operation	1 to 10	These special functions enable you to select and adjust specific portions of circuitry within the HP 8902A. Use these special functions to adapt the instrument's operation to the special needs of your application.
To select the instrument's additional measurement capabilities	11 to 39	These special functions extend the measurement capabilities of the HP 8902A by providing additional measurement modes and functions. Use these special functions to make measurements such as SINAD, Audio Level, and LO Frequency. You can also use them for setting limits, setting references, and manipulating calibration data.
To access service-related operation information	40 to 99	These special functions assist in servicing the HP 8902A by enabling the instrument to display internal voltages and frequencies. Use these special functions to verify operation of the HP 8902A. (Refer to your <i>HP 8902A Service Manual</i> for details on using service special functions.)

The Special Display

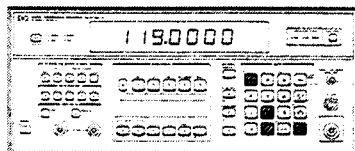

Special function modes are selected first by entering the appropriate code (prefix, decimal point, suffix) and then pressing the SPCL key (lower right corner on the front panel).

1. Key in 7.2 SPCL. The SPCL key remains lit to indicate that a special function has been invoked.

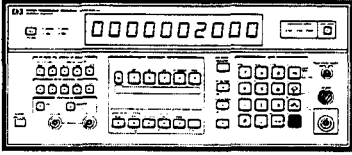

2. **Now press the SPCL key alone.** Pressing the SPCL key without entering a number causes the HP 8902A to display which special functions (1-10) have been set. If you previously entered the 7.2 special function, a 2 should now appear in the seventh display digit position. The display shows a zero in each of the other display positions to indicate that these special functions are still set to their automatic (default) operating condition. Use this capability to review or verify the special function settings that you have selected.

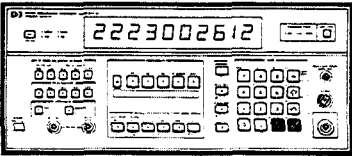

3. **Press the SPCL key again.** Pressing the SPCL key twice without entering a number causes the instrument to display the special function setting (1-10) actually being used. (Note that a 2 still appears in the seventh display digit position.) The other digits represent the settings automatically selected for the measurement mode the HP 8902A is currently in. Use this capability when you are interested in knowing what settings the instrument is currently using to make its measurements.

4. **Press the CLEAR key to exit the special function display and return to the previously selected measurement mode.**

The Special Function Information Pull-Out Card

The Special Function Information pull-out card enables an experienced user to quickly access special function operating information. A block diagram on the card shows which portions of the circuitry are controlled by special functions 1-10. A table of operating conditions for each special function (1-10) is provided below the block diagram. Special functions 11-39 are listed above the block diagram along with a brief description of their function. (Refer to the measurement reference chapters (2 through 4) and the applications chapter (5) to find out how special functions can help you expand your measurement capabilities.)

Errors, Dashes and Other Help

The HP 8902A Measuring Receiver keeps you informed of its operating status by placing error and dash codes in its display. The Operating Information pull-out card enables you to quickly access a brief description of each code. The measurement reference chapters (2 through 4) in this guide provide a listing of the errors and problem conditions for each of the measurement modes. Each code listing includes a description and recommended recovery action. (Refer to reference chapters (2 through 4) for help in solving your measurement problems.)

Congratulations



You are now familiar with each of the basic measurement capabilities of the HP 8902A. From now on, you can rely on the HP 8902A for making your frequency, modulation, audio, power, and level measurements. The rest of this guide will enable you to expand and extend the HP 8902A's measurement capabilities even further. If the scope of your applications goes beyond the contents of this guide, refer to the HP 8902A Operating and Calibration Manual for further details.

2

More about RF Frequency and Frequency Error Measurements

In This Chapter

This chapter introduces the HP 8902A's special operating capabilities that enable you to tailor its RF Frequency and Frequency Error measurements to your specific test conditions. (To use these special capabilities effectively, you should first become familiar with the basic operating capabilities and measurement ranges described in *Chapter 1* for the RF Frequency and Frequency Error measurements.)

This chapter enables you to reference directly to the information you are interested in. The information is organized into three subject areas.

- **Tuning Modes** - Refer here for further understanding of the HP 8902A's tuning modes.
- **Extending Operation** - Refer here for the special operating capabilities that enable you to adapt the HP 8902A to the specific conditions of your input signal.
- **Help** - Refer here for help in solving setup or operating problems encountered in RF Frequency or Frequency Error measurements.

The Directory

Use the directory diagram below to quickly locate the subject you are interested in. A look-up table is located on the first page of each subject area. Use the look-up table to reference to the topics included for that subject.

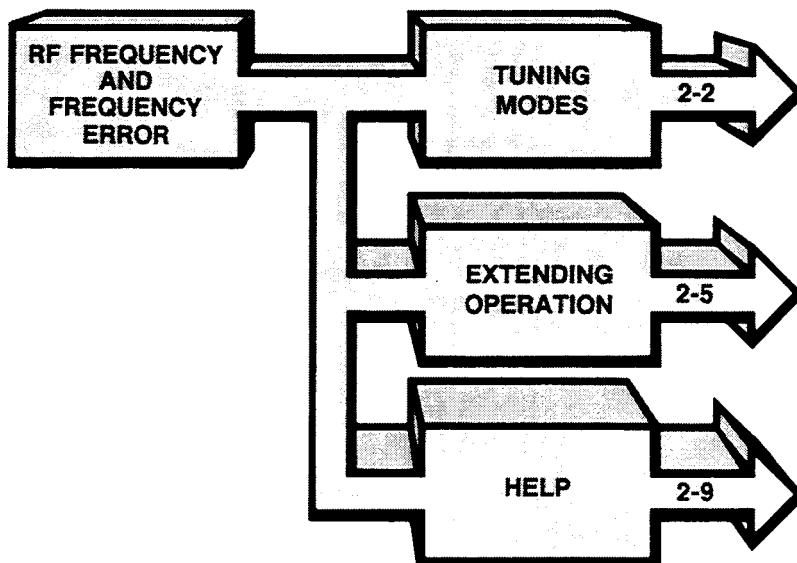

Tuning Modes

If You Need to Know:	Refer to:
• <i>How the Auto Tuning Mode operates</i>	Auto Tuning (2-2)
• <i>How the Manual Tuning Mode operates</i>	Manual Tuning (2-4)
• <i>How Track Mode operates</i>	Track Mode (2-4)

Auto Tuning

Auto tuning allows the HP 8902A to automatically find and tune to the input signal. It is automatically selected on Power-Up, or when the **AUTOMATIC OPERATION** or **INSTR PRESET** key is pressed. Auto Tuning mode is also selected by pressing the **Blue Shift** key and then the **AUTO TUNING** key.

When the HP 8902A enters the Auto Tuning mode, it first checks for an input signal below 2.5 MHz. If no signal is detected below 2.5 MHz, the instrument then begins sweeping its local oscillator (LO) from 1300 MHz down to 2.5 MHz. The LO continues sweeping until a different frequency, created by the mixing of the LO and the RF input signal, appears within the IF passband. If no signal is detected after multiple sweeps, the instrument places two dashes in its display while it continues to sweep.

When a signal does appear within the IF passband, the instrument performs a series of tests to determine whether the signal it has found is the appropriate signal to tune to. This testing enables the HP 8902A to Auto Tune to the fundamental in harmonically-rich spectrums or to a carrier with high-depth AM. Once the instrument determines that it is tuned to the correct frequency, the HP 8902A's LO is locked to an internal crystal oscillator to ensure high-stability, low-noise measurements. If the input signal changes after the LO has been locked to the crystal oscillator in Auto Tuning mode, the LO automatically begins the sweep search again. Auto Tuning mode is a good choice when measuring a single, stable input signal.

Keep in mind that certain input signal conditions can make it difficult for the HP 8902A to Auto Tune. The Manual Tuning mode is a good choice when these conditions exist. For a listing of these conditions, refer to *Table 2-1. Input Conditions that may Require Manual Tuning.*

Table 2-1. Input Conditions That May Require Manual Tuning.

Input Condition	Description	HP 8902A's Response	Recommendation
Multiple input signals	For input signals whose amplitudes are all between -25 dBm and +30 dBm, and are within approximately 15 dB of one another, the HP 8902A may auto tune to the signal at the highest frequency rather than the signal with the highest level.	Instrument will measure and display characteristics of input signal at the highest frequency.	If the desired signal is not the highest-frequency signal, manually tune to the desired frequency or place a bandpass filter at the HP 8902A's input to block the unwanted signals.
Level of 2nd or 3rd harmonic is greater than -10 dBc*	The HP 8902A may interpret these as fundamental signals and tune to the signal at the highest frequency.	Instrument may measure and display characteristics of input signal at the highest frequency.	If the desired signal is not the highest-frequency signal, manually tune to the desired frequency.
Input signals above measurement range (1300 MHz).	Harmonics from the HP 8902A's LO may mix with signals above 1300 MHz to produce beat frequencies within the IF passband.	Instrument may measure and display characteristics of signal above 1300 MHz.	Manually tune to the RF signal below 1300 MHz, or place a low pass filter at the HP 8902A's input to block the unwanted high frequencies.
Low-rate, high-deviation FM	While auto tuning, the HP 8902A may mistake low rate (< 20 Hz) high-deviation (> 400 kHz) FM for signal drift.	Instrument may continuously display four dashes.	Manually tune to the carrier frequency or remove the FM until the instrument has auto tuned to the signal.
Low-level carrier with low-rate, high-depth (percentage) amplitude modulation	The AM may cause the carrier level to move in and out of the HP 8902A's measurement range.	Instrument may continuously display two dashes or 0 MHz, or it may alternately display two dashes then four dashes.	Manually tune to the carrier frequency to increase measurement sensitivity. (Refer to <i>Increasing Sensitivity</i> in this chapter to extend the measurement range further.)

* dBc = decibels referenced to the carrier level.

Manual Tuning

The Manual Tuning mode allows you to set the HP 8902A's tuning at a desired frequency. This is done by keying in the desired frequency and then pressing the **MHz** key. The manual tuning mode can also be entered by pressing the **MHz** key by itself. This locks the instrument at the frequency it is currently tuned to.

In Manual Tuning mode, the HP 8902A's local oscillator (LO) is locked to the HP 8902A's internal crystal oscillator whether an input signal is present or not. Once the LO is locked to the crystal oscillator in Manual Tuning mode, tuning does not change unless a new frequency is keyed in and the **MHz** key is pressed, or tuning is incremented up or down using one of the increment keys, \uparrow **kHz** or \downarrow **kHz**. (Set an increment by keying in the desired increment value and pressing one of the increment keys. The instrument will increment by the keyed-in value each time one of the increment keys is pressed.) Press the **AUTO TUNING** key or the **AUTOMATIC OPERATION** key to exit the Manual Tuning mode.

Manual Tuning is a good choice when measuring an input signal whose amplitude is less than -25 dBm or unstable, or where multiple RF signals are present. If the input signal is drifty, however, it may be necessary to select the Track Mode function.

Track Mode

The Track Mode function enables the HP 8902A to track drifting input signals from 10 MHz to 1300 MHz. Track mode can be selected with either Auto Tuning or Manual Tuning by pressing the **TRACK MODE** key. (A drifting signal will cause the HP 8902A to place four dashes in its display when Auto Tuning is selected or Error 01 when the instrument is manually tuned.)

In Track Mode the Local Oscillator (LO) is locked to the input signal. The instrument remains locked to the signal throughout each of the LO's tuning octaves. When an input frequency change causes the LO to cross into a new octave, lock may be broken. If the instrument is in Auto Tuning Track Mode, the HP 8902A will relock to the input signal. If the instrument is in Manual Tuning Track Mode, the LO will return to the manually tuned setting after lock is broken. The octave boundaries occur at 2.5, 5, 10, 20, 40, 80, 160, 320, 640, and 1280 MHz.

Track Mode is the right choice when measuring drifty input signals. However, certain operating limitations are present when using Track Mode. These limitations are listed below:

- Not allowed below 10 MHz
- Not allowed with 455 kHz IF
- Raises residual FM level
- Attenuates low-rate FM on input signal (use for FM rates >1 kHz only)

Extending Operation

If You Need to Know:	Refer to:
<u>Frequency</u>	
• <i>How to tune to the input signal when other RF signals or harmonics are present</i>	Increasing Selectivity (2-5)
• <i>How to retune to a new input frequency</i>	Changing Frequency (2-6)
• <i>How to tune to a noisy input signal.</i>	Noisy Signal (2-6)
• <i>How to track a drifty input signal ..</i>	Drifty Signal (2-7)
• <i>How to measure the frequency of input signals above 1300 MHz</i>	Frequency Overrange (2-7)
• <i>How to measure the frequency of input signals below 150 kHz</i>	Frequency Underrange (2-7)
<u>Amplitude</u>	
• <i>How to tune to an input signal below -30 dBm</i>	Increasing Sensitivity (2-7)
• <i>How to tune to an input signal whose amplitude is very unstable</i>	Unstable Signal (2-8)

Increasing Selectivity

The HP 8902A's Auto Tuning mode is able to automatically find and tune to the fundamental in a harmonically-rich spectrum as long as the fundamental is at least 10 dB above the level of the second and third harmonics. The HP 8902A will also auto tune to the input signal if it is at least 30 dB above all non-harmonically-related RF signals. If, however, your input signal does not meet these criteria, the HP 8902A may have difficulty auto tuning to the desired input signal. If the instrument does not display the frequency of the desired input signal, manually tune the HP 8902A to the input frequency by keying in the frequency of the input signal and then pressing the **MHz** key.

To minimize the possibility of unwanted low-frequency, harmonic, or spurious signals entering the IF passband, a high-pass RF filter and bandpass IF filters can be selected. Table 2-2 shows the possible filter combination selections.

Table 2-2. Filter Configurations

RF High-Pass Filter (5.25 MHz)	Wide IF Filter	Narrow IF Filter (30 kHz BW)	IF Frequency	Key Sequence
OUT	Automatic Selection			3.0 SPCL
OUT	200 kHz BW	OUT	455 kHz	3.1 SPCL
OUT	2.5 MHz Low-Pass	OUT	1.5 MHz	3.2 SPCL
IN	200 kHz BW	OUT	455 kHz	3.3 SPCL
IN	2.5 MHz Low-Pass	OUT	1.5 MHz	3.4 SPCL
OUT	200 kHz BW	IN	455 kHz	3.5 SPCL
OUT	2.5 MHz Low-Pass	IN	455 kHz	3.6 SPCL
IN	200 kHz BW	IN	455 kHz	3.7 SPCL
IN	2.5 MHz Low-Pass	IN	455 kHz	3.8 SPCL

Changing Frequency

Although the HP 8902A is not designed for swept measurement applications, its Auto Tuning mode does enable it to automatically search for the input signal after the frequency of the input signal is changed. The instrument will place four dashes in its display while it is searching for the input signal.

Image Signals

If the frequency of the signal is increased by an increment equal to twice the IF signal frequency (for example, 2×1.5 MHz), the image frequency will appear within the IF passband. If the switching speed of the input signal is too fast, the HP 8902A will *not* detect a change in the input frequency and will continue to erroneously display the previous frequency. If you suspect that this has happened, press the **Blue Shift** key and then the **AUTO TUNING** key after the input frequency has changed. This causes the HP 8902A to retune to the input signal.

Increasing measurement selectivity by selecting the narrow-band 30 kHz IF filter can reduce the possibility of image signals appearing in the IF passband (refer to **Increasing Selectivity** in this chapter for filter selection information). (For details on the capabilities and limitations of Auto Tuning mode operation, refer to **Auto Tuning** in this chapter.)

Noisy Signal

Excessive noise or low-rate (below 20 Hz), high-deviation (greater than 400 kHz) FM on the carrier signal can make it difficult for the HP 8902A to auto tune to the carrier. If you know that your input signal is noisy, or if the HP 8902A indicates it is having difficulty setting up the measurement by continuously displaying four dashes, manually tune the HP 8902A to the frequency of the input signal. Simply key in the frequency of the input signal and then press the **MHz** key. If the HP 8902A does not display a measurement reading, press the **TRACK MODE** key.

Drifty Signal

A drifty or noisy input signal can cause the instrument to continuously display four dashes (Auto Tuning mode) or display Error 01 (Manual Tuning mode). Press the **TRACK MODE** key to select the wide-IF-bandwidth track mode function. Track Mode can be selected with either the Auto or Manual tuning modes. Note that the Track Mode function reduces the low frequency response of modulation measurements and increases the level of residual modulation. (For details on the capabilities and limitations of Track Mode operation, refer to **Track Mode** in this chapter.)

Frequency Overrange

There are three techniques for extending the HP 8902A's frequency range above 1300 MHz: internal harmonic mixing, external local oscillator and mixer down-conversion, and down-conversion with a spectrum analyzer. All three techniques extend the measurement capabilities of the HP 8902A to microwave frequencies. (Refer to *Chapter 5* for measurement examples using these tuning techniques.)

Frequency Underrange

If the input frequency is below the HP 8902A's frequency measurement range, the instrument will display Error 10. The specified low frequency limit of the RF Frequency measurement is 150 kHz. However, you can extend this measurement range to 20 Hz by simply selecting the Audio Counter. Connect your signal source to the MODULATION OUTPUT/AUDIO INPUT port and press the **AUDIO INPUT** key (key should remain lit). Press the gold **S** key and the **AUDIO FREQ** key. The Audio Counter will accurately count input signals from 20 Hz to 250 kHz.

Increasing Sensitivity

Two dashes or 0 MHz in the display indicates that the level of the input signal is below the HP 8902A's present measurement range. However, the HP 8902A's special function capabilities enable you to make RF Frequency and Frequency Error measurements on input signals down to -100 dBm.

The special function codes and their respective ranges are shown in Diagram 2-1. Keep in mind that these special functions add gain in the RF and IF paths. If the input signal level exceeds the designated range for the special function you select (as shown in Diagram 2-1) the instrument may overrange and display Error 02. Therefore, if you do not know the output level of your source, simply sequence down through the special function range settings until Error 02 is replaced by a measurement reading.

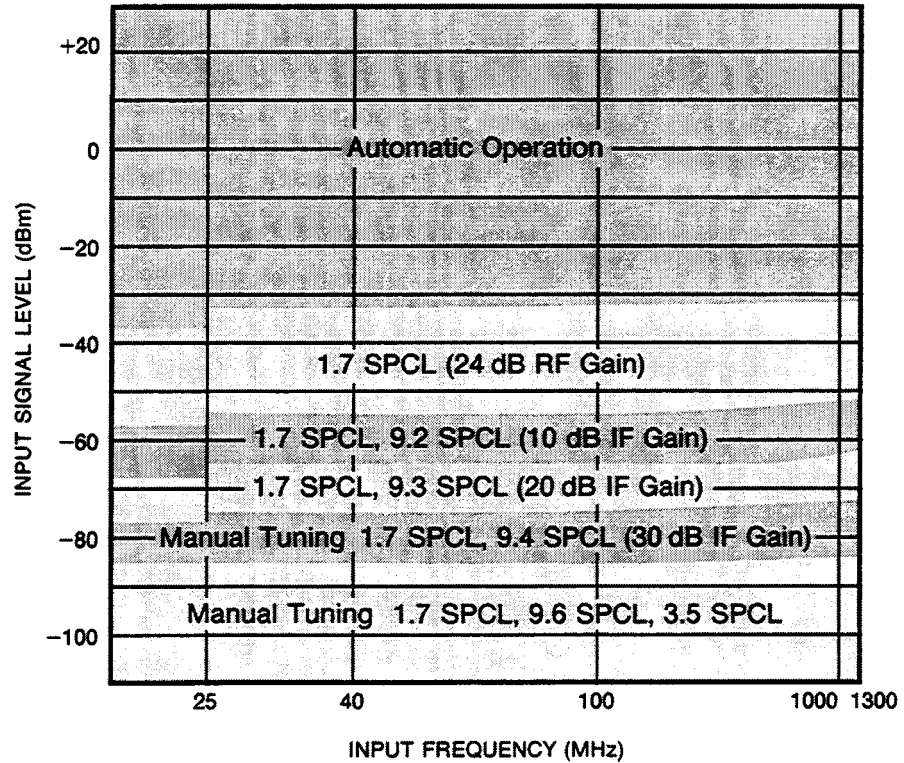

Diagram 2-1. Typical Frequency Measurement Ranges

Unstable Signal

If you are measuring an input signal whose RF level does not remain above -20 dBm to -25 dBm, (for example, a low level signal with high-depth AM or a signal that is being pulsed on and off), select the Manual Tuning mode by keying in the frequency of your input signal and pressing the **MHz** key. In Manual Tuning mode, the instrument will remain locked at the manually tuned frequency after the input signal is turned off.

Help

If You Need to Know:	Refer to:
Setup	
• <i>How to measure frequency without using a Sensor Module.....</i>	No Sensor Module (2-9)
• <i>How to make automated frequency measurements.....</i>	HP-IB (2-9)
• <i>How to connect an external time base</i>	Time Base (2-9)
Measurement	
• <i>How to interpret an error code, dashes or questionable measurement.....</i>	Solving Measurement Problems (2-10)

No Sensor Module

A Sensor Module is not required for making RF Frequency or Frequency Error measurements. To make measurements without a Sensor Module, simply connect a 50Ω cable and Type-N adapter from the HP 8902A's INPUT port to the output of your signal source.

HP-IB

The HP 8902A enables you to fully automate your measurements. Refer to your HP 8902A Operation and Calibration Manual for setup and programming information.

Time Base

A time base input is provided on the rear panel of the HP 8902A. This input allows you to connect the HP 8902A to an external 10 MHz time base. The time base circuitry within the HP 8902A automatically switches to the external time base and turns off its time base output when an external time base of sufficient amplitude (0.5 Vpp) is applied at the input. To verify that an external time base is being used, key in **15.1 SPCL**. The instrument will display a 1 if the external time base is being used or a 0 if the internal time base is being used.

Solving Measurement Problems

The HP 8902A has been designed to feed back information about its operating status. When the HP 8902A detects that the input signal or operating conditions are preventing it from making accurate, reliable measurement, it alerts you by placing an error or dash code in its display.

The circumstances that can cause the HP 8902A to display an error code are classified into one of two categories:

- **Input Problem**, caused by input signal conditions, or
- **Operating Problem**, caused by the selection of incompatible operating functions.

Certain errors are caused *only by an input problem*, other errors are caused *only by an operating problem*, and some errors can be caused by either.

The errors that can be caused *only by an input problem* and the errors that can be caused *only by an operating problem* are listed in the chart below.

If your instrument is displaying one of these errors, proceed directly to *Table 2-3. RF Frequency and Frequency Error, Error Codes*, and take the recovery action recommended.

	Input Problem	Operating Problem
Error	10	09, 12, 20 thru 25, 30, or 32

If you did not find your error listed in the chart or if your instrument is displaying dashes or a questionable measurement, continue with the following procedure.

1. Press the **green AUTOMATIC OPERATION** key. This cancels all function settings that can cause the HP 8902A to display an error code.
2. Compare the operating status of your HP 8902A *after pressing the AUTOMATIC OPERATION* key with the following condition descriptions. After you have identified the description that best describes your instrument's condition, take the action recommended for that condition.

Same Error If the error or reading remains the same after the **AUTOMATIC OPERATION** key has been pressed, the error is being caused by an input problem. Look up the error code in Table 2-3 and take the action recommended for "Input Problem".

No Error If the error goes away after the **AUTOMATIC OPERATION** key has been pressed, the error was caused by an operating problem. Look up the error code in Table 2-3 and take the action recommended for "Operating Problem".

New Error If the error is replaced by a different error or dash code after the **AUTOMATIC OPERATION** key has been pressed, the original error was being caused by a combined input problem and operating problem. Look up the error code displayed by the instrument *after* the **AUTOMATIC OPERATION** key was pressed. Take the action recommended for "Input Problem".



Remember

Because of the wide variety of input signals and the operating flexibility of the HP 8902A, it is not possible to list all recovery actions for each error code. After using the table to determine the cause of the problem, you may discover other error recovery procedures that are better suited to your application.

Table 2-3. RF Frequency and Frequency Error, Error Codes (1 of 2)

Display Code	Problem Description	Input Problem	Operating Problem
Questionable Measurement	Instrument does not display frequency of the input signal.	Check tuning mode. Refer to Increasing Selectivity (2-5) or Drifty Signal (2-7) .	Recheck operating conditions being used.
-- or 0 MHz	Input signal level out of measurement range.	Adjust input signal level or change measurement sensitivity. Refer to Increasing Sensitivity (2-7) .	Decrease RF attenuation or gain. Refer to Increasing Sensitivity (2-7) .
----	Instrument has detected an input signal and is attempting to set up measurement. Continuous display indicates instrument is having difficulty tuning to input signal	Manually tune to input signal. Refer to Noisy Signal (2-6) .	Re-check operating conditions being used.
01	IF signal within IF passband but not centered well enough to guarantee measurement accuracy (due to manual tuning). High AM depth (>95%) on low-level carrier.	Increase input signal level or decrease AM. Refer to Increasing Sensitivity (2-7) .	Press the MHz key to center IF signal in IF passband. If problem persists, signal may be drifting. Refer to Drifty Signal (2-7) .

Table 2-3. RF Frequency and Frequency Error, Error Codes (2 of 2)

Display Code	Problem Description	Input Problem	Operating Problem
02	Input circuits overdriven.	Increase RF input attenuation. Refer to <i>Increasing Sensitivity (2-7)</i> .	Decrease RF and/or IF gain setting. Refer to <i>Increasing Sensitivity (2-7)</i> .
03	Input circuits underdriven.	Increase gain. Refer to <i>Increasing Sensitivity (2-7)</i> .	Decrease RF input attenuation or increase IF gain. Refer to <i>Increasing Sensitivity (2-7)</i> .
06	Input circuits overdriven.	Input level exceeds 7 Vrms (1W peak). Decrease level of input signal.	Decrease RF and/or IF gain setting. Refer to <i>Increasing Sensitivity (2-7)</i> .
09	High stability time base problem (Option 002 instruments only).		Check internal time base for malfunction.
10	Frequency of input signal is not within measurement range.	Adjust frequency of input signal to within measurement range, or increase measurement range. Refer to <i>Frequency Overrange (2-7)</i> and <i>Frequency Underrange (2-7)</i> .	
12	Indicates internal time base oven cold (Option 002 instruments only).		Wait for oven to warm for highest accuracy.
17	IF level not within its measurement range.	Input signal level during reference measurement must be between 1.25V and 2.50V. (Option 030 only.)	Check selected RF or IF gain. Refer to <i>Increasing Sensitivity (2-7)</i> . (When making Ratio measurements, allow instrument to complete the reference measurement.)
20	Frequency entered exceeds measurement range.		Re-enter frequency within measurement range. (In Ratio mode, a reference measurement of zero is invalid.)
21	Invalid entry.		Check compatibility of function(s) with selected measurement mode.
22	Invalid Special Function prefix entered.		Check Special Function number and re-enter.
23	Invalid Special Function suffix entered.		Check Special Function number and re-enter.
25	Selected Special Function not compatible with measurement mode Special Function(s).		Check Special Function compatibility with measurement.
30	Inappropriate RF attenuation or gain setting.		Check RF attenuation and gain settings.
32	Inappropriate IF gain setting.		Check IF gain setting.

3

More about Modulation and Audio Measurements

In This Chapter

This chapter introduces the HP 8902A's special operating capabilities that enable you to adapt its modulation and audio measurements to your specific test conditions. (To use these special capabilities effectively, you should first become familiar with the basic operating capabilities and measurement ranges described in *Chapter 1* for the Modulation and Audio measurements.)

This chapter enables you to reference directly to the information you are interested in. The information is organized into three subject areas.

- **Calibration** - Refer here for the procedure to calibrate your AM and FM measurements.
- **Extending Operation** - Refer here for the special operating capabilities that enable you to adapt the HP 8902A to meet the specific conditions of your input signal.
- **Help** - Refer here for help in solving setup or operating problems encountered in Modulation or Audio measurements.

The Directory

Use the directory diagram below to quickly locate the subject you are interested in. A look-up table is located on the first page of each subject area. Use the look-up table to reference to the topics included for that subject.

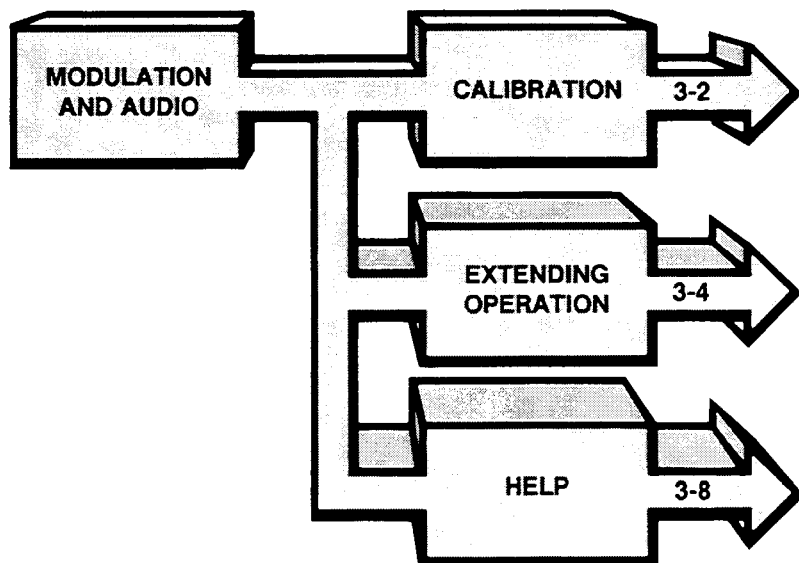

Calibration

The HP 8902A meets its specified AM and FM measurement accuracy without needing any additional calibration other than the recommended procedure performed annually to re-calibrate the entire instrument. The following calibration procedure allows you to further enhance the accuracy of your AM and FM measurements, however.

AM and FM Calibration

By making comparative measurements against a known modulation level (provided by the AM/FM CALIBRATION output port), the instrument creates a calibration factor that can be used to minimize measurement error. Once the calibration factor has been created, you have control over when it is used by the instrument. (There is not a calibration procedure for the Φ M measurement.)

The following chart lists the special function codes for enabling, disabling, or displaying the calibration factor. After you have enabled the calibration factor, the HP 8902A will automatically apply it to its AM or FM measurements.

Calibration Factor	AM	FM
Disable	16.0 SPCL	17.0 SPCL
Enable	16.1 SPCL	17.1 SPCL
Display	16.2 SPCL	17.2 SPCL



Note

To ensure the highest possible measurement accuracy, allow the HP 8902A to warm up at least thirty minutes before performing the calibration procedure. Also, to ensure that the measurement circuitry is fully settled, allow the HP 8902A to update the calibration factor at least three times before completing the calibration procedure. (The calibration factor is updated approximately every 17 seconds while the Calibrator is on.)

-
1. Connect the HP 11722A Sensor Module (or a 50 ohm cable and Type-N adapter) from the INPUT 50 Ω port to the AM/FM CALIBRATION output port (lower left corner on front panel).
 2. Press the AM or FM key to select the measurement you wish to calibrate. You will need to repeat this entire procedure twice if you wish to calibrate both your AM and FM measurements.
 3. Press the CALIBRATE key to turn on the Calibrator. Wait for the Calibration Factor to be displayed. The calibration factor will be displayed as a percentage. This percentage indicates the relationship between the HP 8902A's measurement and the actual output of the Calibrator. (For example, a calibration factor of 100% indicates that the measured value is exactly the same as the calibrator output value. Likewise, a calibration factor of 100.17% indicates that the HP 8902A is measuring .17% above the Calibrator's actual output.)

**Remember**

While the HP 8902A is in the Calibration mode (Calibrator key lit), the calibration factor is stored in the instrument's non-volatile memory each time it is updated (approximately every 17 seconds). To ensure that the measurement circuitry is fully settled, allow the instrument to update the calibration factor at least three times before proceeding.

4. Press the Blue Shift key and then the SAVE CAL key (only when in the Calibration mode) to enable the calibration factor (the same as entering 16.1 or 17.1 SPCL when not in the Calibration mode). Wait for the calibration factor to be displayed.
5. Press the CALIBRATE key to turn off the Calibrator. The calibration procedure is complete. You can now connect the HP 8902A to your signal source and be assured that you are making the most accurate modulation measurements possible with the HP 8902A.

Extending Operation

If You Need to Know:	Refer to:
<u>Frequency</u>	
• How to make sure you are tuned to the carrier	Check Tuning (3-4)
• How to tune to the carrier when other RF signals or harmonics are present	Increasing Selectivity (3-5)
• How to retune to a new input frequency	Changing Frequency (3-5)
• How to tune to a noisy carrier	Noisy Carrier (3-6)
• How to track a drifty carrier	Drifty Carrier (3-6)
• How to measure modulation on a carrier above 1300 MHz	Frequency Overrange (3-6)
• How to measure modulation on a carrier below 150 kHz	Frequency Underrange (3-6)
<u>Amplitude</u>	
• How to tune to a carrier below -30 dBm	Increasing Sensitivity (3-7)
• How to tune to a carrier whose amplitude is very unstable	Unstable Carrier (3-7)

Check Tuning

For most applications, the HP 8902A's Auto Tuning mode enables the instrument to automatically tune to the input signal. (Auto Tuning mode is the right choice for measuring modulation on a single, stable carrier.) The HP 8902A will inform you that it is having difficulty tuning by placing dashes, error codes, or a very inaccurate reading in its display.

You can check what frequency the HP 8902A is currently tuned to at any time during the measurement by pressing the **Blue Shift** key and then the **DISPLAY FREQ (↑kHz)** key. A way to ensure that the instrument is tuned to the desired frequency is to manually tune it by keying in the input frequency and then pressing the **MHz** key. (If you are interested in details on how the instrument operates in its Manual Tuning mode, refer to *Chapter 2*.)

Increasing Selectivity

The selectivity of your modulation and audio measurements above 10 MHz can be increased by selecting the 455 kHz IF. Key in 3.1 SPCL to select the 455 kHz IF with a 200 kHz bandwidth, or key in 3.7 SPCL to select 455 kHz IF with maximum selectivity of 30 kHz. (Note that the 455 kHz IF should only be selected for measuring modulation rates below 10 kHz.) To further increase the selectivity of your measurement, select low-pass, high-pass, or bandpass audio filtering using the Audio Filter keys on the front panel.

The HP 8902A's Auto Tuning mode is able to automatically find and tune to the fundamental in a harmonically-rich spectrum as long as the fundamental is at least 10 dB above the level of the second and third harmonics. The HP 8902A will also auto tune to the carrier if the carrier is at least 30 dB above all non-harmonically related RF signals. If, however, your input signal does not meet these criteria, the HP 8902A may have difficulty auto tuning to the carrier. If the HP 8902A tunes to a signal other than the carrier, it will cause the instrument to display modulation and audio readings for that signal rather than the carrier.

To check what RF frequency the HP 8902A is actually tuned to, press the **FREQ** key. If the instrument does not display the correct carrier frequency, manually tune the HP 8902A to the carrier frequency; key in the frequency of the carrier and then press the **MHz** key. (Refer to *Chapter 2* for details on the Auto Tuning and Manual Tuning modes.)

Changing Frequency

Although the HP 8902A is not designed for swept measurement applications, its Auto Tuning mode does enable it to automatically search for the carrier signal when carrier frequency is changed. (For details on the capabilities and limitations of Auto Tuning mode operation, refer to *Chapter 2*.)

Noisy Carrier

Excessive noise or low-rate (below 20 Hz), high-deviation (greater than 400 kHz) FM on the carrier signal can make it difficult for the HP 8902A to auto tune to the carrier. If you know that your carrier is noisy, or if the HP 8902A indicates it is having difficulty setting up the measurement by continuously displaying four dashes, manually tune the HP 8902A to the carrier frequency. Simply key in the frequency of the carrier and then press the **MHz** key. If the HP 8902A does not display a measurement reading, press the **TRACK MODE** key. (Refer to *Chapter 2* if you are interested in details on how the instrument operates in Manual Tuning mode and Track mode.)

Drifty Carrier

The HP 8902A is able to track drifting or noisy RF signals without sacrificing measurement bandwidth or level sensitivity. A drifting input signal can cause the instrument to continuously display four dashes (Auto Tuning mode) or display Error 01 (Manual Tuning mode). Press the **TRACK MODE** key to select the wide IF-bandwidth track mode function. Track Mode can be selected with either the Auto or Manual tuning modes. Note that the Track Mode function reduces the low frequency response of modulation measurements and increases the level of residual modulation. (For details on the capabilities and limitations of Track Mode operation, refer to *Chapter 2*.)

Frequency Overrange

There are three techniques for extending the HP 8902A's frequency range above 1300 MHz: internal harmonic mixing, external local oscillator and mixer down-conversion, and down-conversion with a spectrum analyzer. All three techniques extend the AM, FM, and Φ M measurement capabilities of the HP 8902A to microwave frequencies. Refer to *Chapter 5* for measurement examples using these tuning techniques.

Frequency Underrange

The specified low frequency limit of the HP 8902A is 150 kHz. However, you can extend this measurement range to below 50 kHz. The procedure is simple. First, manually tune the HP 8902A to 100 MHz and override Error 01 by keying in **8.1 SPCL**. This enables the input signal to pass directly through the input mixer without frequency conversion. Next, suppress IF feedthrough by selecting the 3 kHz or 15 kHz low-pass filter. The analyzer is now ready to make modulation measurements. If you wish to display the carrier frequency, key in **34.0 SPCL** (press the **AM** key to return to the AM measurement mode).

Increasing Sensitivity

Two dashes or 0 MHz in the display indicates that the level at the input signal is below the HP 8902A's present measurement range. However, the HP 8902A's special function capabilities enable you to make modulation and audio measurements on carrier signals down to -75 dBm.

The special function codes and their respective ranges are shown in Diagram 3-1. (Keep in mind that these special functions add gain in the RF and IF paths. Enabling them for an input signal that exceeds the designated range for that special function (as shown in Diagram 3-1) may cause the instrument to overrange and display Error 02.) If you do not know the output level of your source, sequence through the ranges until the HP 8902A displays a measurement reading.

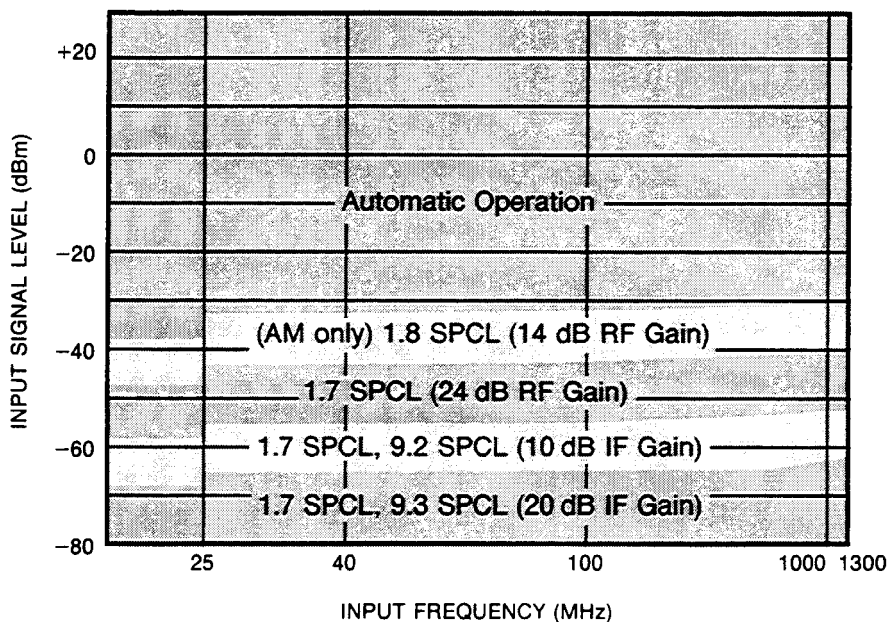

Diagram 3-1. Typical Modulation and Audio Measurement Ranges

Unstable Carrier

If you are measuring modulation on a carrier signal whose RF level does not remain above -20 to -25 dBm (for example, a carrier that is being pulsed on and off), select the Manual Tuning mode by keying in the frequency of your carrier signal and then pressing the **MHz** key. In Manual Tuning mode, the instrument will remain locked at the frequency of the carrier after the carrier is turned off. (For details on the instrument's operation when in the Manual Tuning mode, refer to Chapter 2.)

Help

If You Need to Know:	Refer to:
Setup	
• <i>How to measure modulation or audio without using a Sensor Module.....</i>	No Sensor Module (3-8)
• <i>How to make automated modulation or audio measurements.....</i>	HP-IB (3-8)
• <i>How to connect an external time base</i>	Time Base (3-8)
Measurement	
• <i>How to interpret an error code, dashes, or questionable measurement.....</i>	Solving Measurement Problems (3-8)

No Sensor Module

A Sensor Module is not required for making modulation or audio measurements. To make measurements without a Sensor Module, simply connect a 50 Ω cable and Type-N adapter from the HP 8902A's INPUT port to the output of your signal source.

HP-IB

The HP 8902A enables you to fully automate your modulation and audio measurements. Refer to your HP 8902A Operation and Calibration Manual for set-up and programming information.

Time Base

A time base input is provided on the rear panel of the HP 8902A. This input allows you to connect the HP 8902A to an external 10 MHz time base. The time base circuitry within the HP 8902A automatically switches to the external time base and turns off the time base output when an external time base of sufficient amplitude (0.5 Vpp) is applied at the input. To verify that an external time base is being used, key in **15.1 SPCL**. The instrument will display a 1 if the external time base is being used or a 0 if the internal time base is being used.

Solving Measurement Problems

The HP 8902A has been designed to feed back information about its operating status. When the HP 8902A detects that the input signal or operating conditions are preventing it from making an accurate, reliable measurement, it alerts you by placing an error or dash code in its display.

The circumstances that can cause the HP 8902A to display an error code are classified into one of two categories:

- **Input Problem**, caused by input signal conditions, or
- **Operating Problem**, caused by the selection of incompatible operating functions.

Certain errors are caused *only by an input problem*, other errors are caused *only by an operating problem*, and some errors can be caused by either.

The errors that can be caused *only by an input problem* and the errors that can be caused *only by an operating problem* are listed in the chart below.

If your instrument is displaying one of these errors, proceed directly to **Table 3-1. Modulation and Audio Error Codes** and take the recovery action recommended.

	Input Problem	Operating Problem
Error	05, 08, 10, or 16	09, 11, 12, 20 thru 25, 30, or 32

If you did not find your error listed in the chart, or if your instrument is displaying dashes or a questionable measurement, perform the following procedure.

1. **Press the green AUTOMATIC OPERATION key.** This cancels all function settings that can cause the HP 8902A to display an error code.
2. **Compare the operating status of your HP 8902A after pressing the AUTOMATIC OPERATION key with the following list of conditions.** After you have identified the description that best describes your instrument's condition, take the action recommended for that condition.

Same Error

If the error or reading remains the same after the **AUTOMATIC OPERATION** key has been pressed, the error is being caused by an input problem. Look up the error code in Table 3-1 and take the action recommended for "Input Problem".

No Error

If the error goes away after the **AUTOMATIC OPERATION** key has been pressed, the error was caused by an operating problem. Look up the error code in Table 3-1 and take the action recommended for "Operating Problem".

New Error

If the error is replaced by a different error or dash code after the **AUTOMATIC OPERATION** key has been pressed, the original error was being caused by a combined input problem and operating problem. Look up the error code displayed by the instrument *after* the **AUTOMATIC OPERATION** key was pressed. Take the action recommended for "Input Problem".

Remember

Because of the wide variety of input signals and the operating flexibility of the HP 8902A, it is not possible to list all recovery actions for each error code. After using the table to determine the cause of the problem, you may discover other error recovery procedures that are better suited to your application.

Table 3-1 Modulation and Audio Error Codes (1 of 3)

Display Code	Problem Description	Input Problem	Operating Problem
Questionable Measurement	1. Measurement is very inaccurate. 2. Measurement is slightly inaccurate.	1. Check tuning mode. Refer to Increasing Selectivity (3-5) or Drifty Carrier (3-6) . Check modulation source. 2. Check Calibration (3-2) .	Recheck operating conditions being used.
-- or 0 MHz	Input signal level below measurement range.	Increase input signal level or increase measurement sensitivity. Refer to Increasing Sensitivity (3-7) .	Decrease RF attenuation. Refer to Increasing Sensitivity (3-7) .
----	Instrument has detected an input signal and is attempting to set up measurement. Continuous display indicates instrument is having difficulty tuning to the input signal.	Manually tune to input signal. Refer to Noisy Carrier (3-6) .	Re-check operating conditions being used.
01	IF signal within IF passband but not centered well enough to guarantee measurement accuracy (due to manual tuning). High AM depth (>95%) on low-level carrier.	Increase carrier signal level or decrease AM. Refer to Increasing Sensitivity (3-7) .	Press the MHz key to center IF signal in IF passband. If problem persists, signal may be drifting. Refer to Drifty Carrier (3-6) .

Table 3-1 Modulation and Audio Error Codes (2 of 3)

Display Code	Problem Description	Input Problem	Operating Problem
02	Input circuits overdriven.	Increase RF input attenuation. Refer to <i>Increasing Sensitivity (3-7)</i> .	Decrease RF and/or IF gain setting. Refer to <i>Increasing Sensitivity (3-7)</i> .
03	Input circuits underdriven.	Increase gain. Refer to <i>Increasing Sensitivity (3-7)</i> .	Decrease RF input attenuation or increase IF gain. Refer to <i>Increasing Sensitivity (3-7)</i> .
04	Modulation level on input signal exceeds modulation range limit.	Decrease modulation level on input signal to within measurement range.	Increase range limit setting, Special Function 2.N.
05	AM depth is too high (>90%) for carrier level while making FM or Φ M measurements.	Increase carrier level or decrease AM depth (<90%).	
06	Input circuits overdriven.	Input level exceeds 7 Vrms (1W peak). Decrease level of input signal.	Decrease RF and/or IF gain setting. Refer to <i>Increasing Sensitivity (3-7)</i> .
07	Modulation on input signal exceeds measurement range.	Decrease modulation level on input signal.	Increase limit setting, Special Function 2.N.
08	Calibrator output not sensed at INPUT.	Check connection to Calibrator. Check for Calibrator malfunction.	
09	High stability time base problem (Option 002 instruments only).		Check internal time base for malfunction.
10	Frequency of input signal is not within measurement range.	Adjust frequency of input signal to within measurement range, or increase measurement range. Refer to <i>Frequency Overage (3-6)</i> and <i>Frequency Underrange (3-6)</i> .	

Table 3-1 Modulation and Audio Error Codes (3 of 3)

Display Code	Problem Description	Input Problem	Operating Problem
11	dB Ratio measurement results in calculated value ≤ 0 (log 0 not allowed).		Key in a different ratio reference.
12	Indicates internal time base oven cold (Option 002 instruments only).		Wait for oven to warm for highest accuracy.
16	Level of audio signal at Audio Input too low.	Increase audio signal level.	
17	IF level not within its measurement range.	Input signal level during reference measurement must be between 1.25V and 2.50V.	Check selected RF or IF gain level. Refer to <i>Increasing Sensitivity (3-7)</i> . (When making Ratio measurements, allow instrument to complete the reference measurement.)
20	Frequency entered exceeds measurement range.		Re-enter frequency within measurement range. (In Ratio mode, a reference measurement of zero is invalid.)
21	Invalid entry.		Check compatibility of function(s) with selected measurement mode.
22	Invalid Special Function prefix entered.		Check Special Function number and re-enter.
23	Invalid Special Function suffix entered.		Check Special Function number and re-enter.
25	Selected Special Function not compatible with measurement mode Special Function(s).		Check Special Function compatibility with measurement.
30	Inappropriate RF attenuation or gain setting.		Check RF attenuation and gain settings.
32	Inappropriate IF gain setting.		Check IF gain setting.

4

More about RF Power and Tuned RF Level Measurements

In this Chapter

This chapter introduces the HP 8902A's special operating capabilities that enable you to adapt its RF Power and Tuned RF Level (TRFL) measurements to your specific test conditions. (To use these special capabilities effectively, you should first become familiar with the basic operating capabilities and measurement ranges described in *Chapter 1* for the RF Power and TRFL measurements.)

This chapter enables you to reference directly to the information you are interested in. The information is organized into three subject areas.

- **Calibration** - Refer here for information about the RF Power and TRFL calibration technique.
- **Extending Operation** - Refer here for the special operating capabilities that enable you to adapt the HP 8902A to meet the specific conditions of your input signal.
- **Help** - Refer there for help in solving setup or operating problems encountered in RF Power or TRFL measurements.

The Directory

Use the directory diagram below to quickly locate the subject you are interested in. A look-up table is located on the first page of each subject area. Use the look-up table to reference to the topics included for that subject.

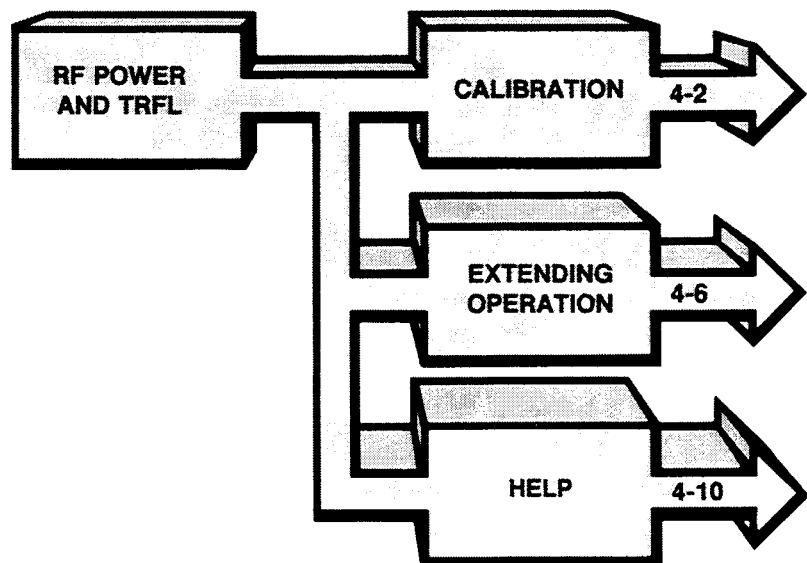

Calibration

If You Need to Know:	Refer to:
• <i>How to maintain RF Power calibration</i>	RF Power Calibration (4-2)
• <i>More about the TRFL calibration technique</i>	TRFL Calibration (4-3)
• <i>The accuracy of TRFL measurements</i>	TRFL Accuracy (4-5)

RF Power Calibration

The RF Power calibration procedure is shown in *Chapter 1* of this guide. Once the procedure has been completed it does not need to be repeated again unless you change Sensor Modules or the calibration factors for the Sensor Module you are using change (due to repair or recalibration of the Sensor Module). (If the Sensor Module or the calibration factors are changed, you will need to complete the calibration factor entry procedure provided in *Appendix B* before proceeding with the calibration procedure shown in *Chapter 1*.)

To Maintain Accuracy

To maintain calibration accuracy, it is necessary to periodically press the **ZERO** key (approximately once every ten minutes while making RF Power measurements is recommended and each time you connect the sensor to a different output port). Pressing the **ZERO** key enables the HP 8902A to compensate for any inherent, dc-offset error in the measurement system caused by changes in the ambient operating temperature.

Tuning

You may remember that in *Chapter 1* you were told that the HP 8902A should be tuned to the frequency of the input signal when making RF Power measurements. Even though the RF Power measurement is not a tuned measurement, the instrument uses the frequency setting to determine the appropriate calibration factor to select from the table of power sensor calibration factors stored in its memory. (If a calibration factor is not stored for the specific frequency being measured, the HP 8902A derives a calibration factor by linear interpolation between the closest calibration factors in the storage table on both sides of the measurement frequency.)

TRFL Calibration

The TRFL calibration procedure is described in *Chapter 1*. Table 4-1 will help you remember the key steps to calibrating your TRFL measurements.

Table 4-1. Tuned RF Level Calibration Procedure

Key Steps	Considerations		
1. Set the level of your signal source to between 0 and -20 dBm (0 dBm is optimum).	The three RF measurement ranges must be calibrated sequentially beginning with Range 1.		
	IF Detector		
	Range	Synchronous	Average
	1	0 dBm	0 dBm
2	-40 dBm	-15 dBm	
3	-80 dBm	-50 dBm	
2. Tune the HP 8902A to the frequency of your signal source.	Manually: Key in the frequency and press the MHz key, or Automatically: Press the FREQ key and select Auto Tuning. After the frequency is displayed, press the MHz key to select Manual Tuning and then re-enter the TRFL measurement mode.		
3. Press the CALIBRATE key each time the RECAL annunciator lights	The RECAL annunciator will only appear three times for each frequency (once for each measurement range). Remember not to change the input signal level during calibration (while the CALIBRATE key is lit).		

The IF Synchronous Detector

The calibration procedure described in *Chapter 1* enables you to make TRFL measurements using the HP 8902A's IF Synchronous detector. The IF Synchronous detector makes a very narrow band (200 Hz) power measurement and provides the greatest TRFL measurement sensitivity (-127 dBm). (The IF Synchronous detector is the default selection for the HP 8902A.)

The IF Average Detector

A second detector is also available for making TRFL measurements. This detector is the IF Average detector and it is selected by keying in **4.4 SPCL**. After you have selected the IF Average detector, perform the procedure shown in Table 4-1 to calibrated your TRFL measurements.

The measurement bandwidth of the IF Average detector is set by a 30 kHz IF filter. (A 200 kHz IF filter can also be selected, refer to **Increasing Selectivity** in this chapter for details). The increased measurement bandwidth of the IF Average detector reduces its measurement sensitivity to less than that of the IF Synchronous detector. (Diagram 4-1 shows a comparison of the measurement ranges for the IF Synchronous detector and the IF Average detector.) Key in **4.0 SPCL** when you wish to reselect the IF Synchronous detector.

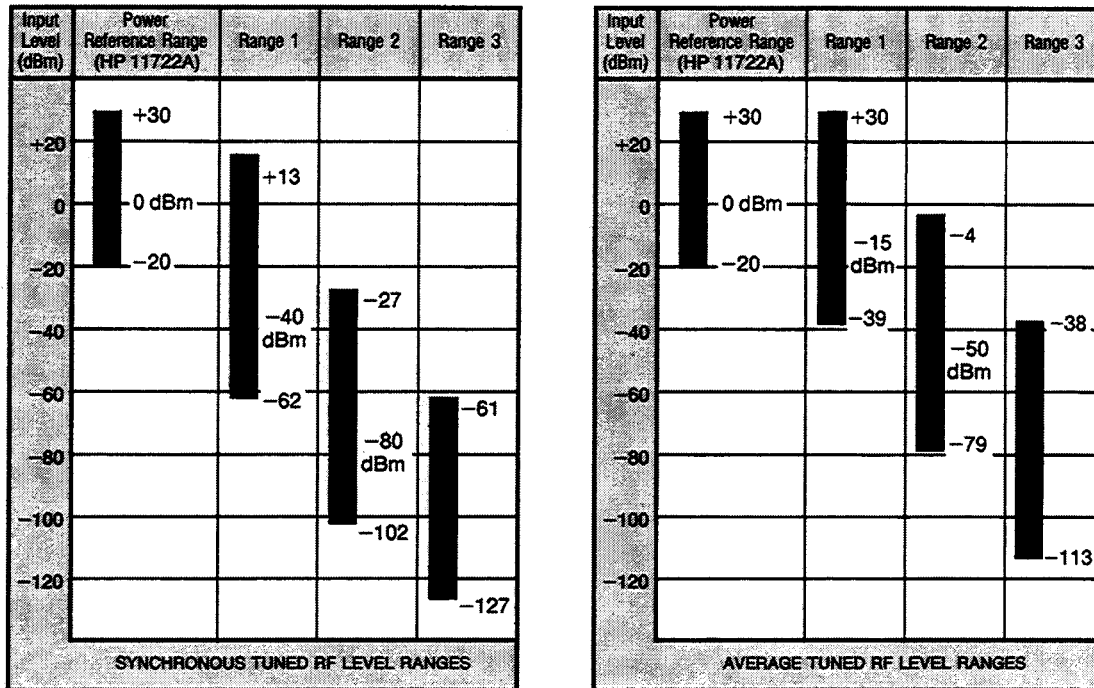

Diagram 4-1. The Measurement Ranges for the IF Synchronous and IF Average Detectors

The Calibration Technique

You may remember, that in the TRFL calibration procedure in *Chapter 1* you were instructed to adjust the input signal to specific levels (0, -40, and -80 dBm). Note in Diagram 4-1 that each of the specified levels is within the overlap (calibration) region between two RF measurement ranges for the IF Synchronous detector. When you adjusted the input signal to each of these levels the RECAL annunciator in the display was lit and you were instructed to press the **CALIBRATE** key.

Range 1

When you pressed the **CALIBRATE** key to calibrate Range 1, the HP 8902A measured the level of the input signal twice. Once using its RF Power meter circuitry and once using the IF Synchronous detector and the Range 1 circuit configuration. By comparing the two measurements, the HP 8902A created a TRFL calibration factor for Range 1 that equated the Range 1 measurement to the calibrated RF Power measurement. This TRFL calibration factor transferred the absolute accuracy of the RF Power measurement to all Range 1 TRFL measurements made at that frequency.

Remember



*This double measurement technique makes it very important that the level of the input signal remain stable throughout the calibration process (while the **CALIBRATE** key is lit).*

Relative TRFL Measurements

The RF Power measurement-to-Range 1 transfer uncertainty is ± 0.06 dB. This transfer uncertainty can be eliminated by using the HP 8902A's SET REF mode to make relative power measurements. When the **SET REF** key is pressed, the HP 8902A establishes the current level of the input signal as the 0 dB-reference for Range 1. The SET REF mode enables the HP 8902A to measure relative level changes of linear devices, such as attenuators, directly and accurately. (Refer to *Chapter 5* for an example of how the SET REF mode is used for attenuator testing.)

Ranges 2 and 3

The double measurement calibration technique is also used to transfer measurement accuracy from Range 1 to Range 2 and from Range 2 to Range 3. The Range 1 to Range 2 and Range 2 to Range 3 transfer uncertainty is ± 0.04 dB.

IF Ranges

In addition to the operating changes that occur within the HP 8902A to produce the three RF measurement ranges, there are also operating changes that occur within each of the three RF measurement ranges. These changes occur as 10 dB amplifiers in the IF path are switched in, and as the selected IF detector is stepped over its 15 dB measurement range. Because the amplifiers and IF detector are very linear, the typical range-to-range error for the amplifiers is less than ± 0.02 dB per change, and detector linearity uncertainty (for the IF Synchronous detector) is less than ± 0.02 dB over each RF measurement range (1 through 3).

TRFL Accuracy

Although calculating precise measurement uncertainty for a TRFL measurement can involve several uncertainty factors, Graph 4-1 demonstrates that even for worst case the total TRFL measurement uncertainty is minimal.

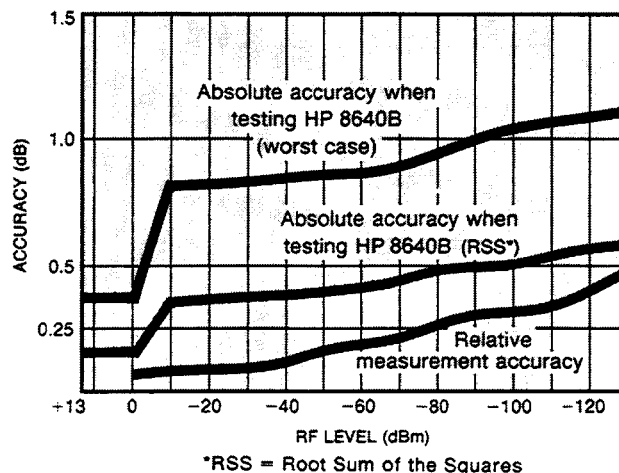

Graph 4-1. Tuned RF Level Measurement Accuracy.

Extending Operation

If You Need to Know:	Refer to:
<u>Frequency</u>	
• <i>How to tune to the input signal</i>	Tuning (4-7)
• <i>How to measure TRFL when other RF signals or spurs are present</i>	Increasing Selectivity (4-7)
• <i>How to quickly repeat TRFL measurements at various frequencies</i>	Repeating Measurements (4-8)
• <i>How to measure the TRFL of a noisy input signal</i>	Noisy Signal (4-8)
• <i>How to measure the TRFL of a drifty input signal</i>	Drifty Signal (4-9)
• <i>How to measure the TRFL of an input signal above 1300 MHz</i>	Frequency Overrange (4-9)
• <i>How to measure the TRFL of a signal below 2.5 MHz</i>	Frequency Underrange (4-9)
<u>Amplitude</u>	
• <i>How to measure a low-level signal source that can not be increased to above -20 dBm</i>	Low-Level Signal (4-9)
• <i>How to minimize measurement uncertainty due to SWR</i>	Input Impedance (4-9)

Tuning

Both the RF Power and TRFL calibration techniques require that the HP 8902A is tuned to the frequency of the input signal. As shown in *Chapter 1*, there are two ways to tune to the input signal. If you know the frequency of your input signal, the most direct way to tune is by keying in the frequency of the input signal and then pressing the **MHz** key. If you do not know the input frequency, set the input signal level to between 0 and -20 dBm, then press the **FREQ** key, the **Blue Shift** key, and the **AUTO TUNING** key on the HP 8902A. When the HP 8902A displays the frequency of the input signal, press the **MHz** key to select Manual Tuning, and then re-enter the TRFL measurement mode and proceed with your measurement.

Increasing Selectivity

To minimize the possibility of unwanted low frequency and spurious signals entering the passband of the TRFL measurement, a high-pass RF filter and bandpass IF filter can be selected. (Table 4-2 shows the filter configurations possible for the TRFL measurement.) Remember that when using the IF Average detector, the IF filters determine measurement bandwidth. (Be sure to select the desired filters before performing the TRFL calibration.)

Table 4-2. Filter Configurations

RF High-Pass Filter (5.25 MHz)	Wide IF Filter	Narrow IF Filter (30 kHz BW)	Key Sequence
OUT	Automatic Selection		3.0 SPCL
OUT	200 kHz BW	OUT	3.1 SPCL
IN	200 kHz BW	OUT	3.3 SPCL
OUT	200 kHz BW	IN	3.5 SPCL
OUT	2.5 MHz Low-Pass	IN	3.6 SPCL
IN	200 kHz BW	IN	3.7 SPCL
IN	2.5 MHz Low-Pass	IN	3.8 SPCL

Repeating Measurements

You can quickly repeat TRFL measurements at various frequencies using the HP 8902A's eight storage registers. After you have completed the TRFL calibration procedure at a given frequency, set the level of the input signal to between 0 and -20 dBm (so that the HP 8902A is in measurement Range 1). Then press the **Blue Shift** key, the **STORE (7)** key and a digit key (**1-8**) to store the instrument's complete operating condition including calibration data into one of the instrument's storage registers.

All of the HP 8902A's current operating conditions including calibration data will be retained in the selected storage register through power down. Whenever you wish to repeat the TRFL measurement at the given stored frequency, select the appropriate register by pressing the **Blue shift** key, the **RECALL (8)**, key and the appropriate digit key. The instrument will restore all of its operating conditions to the configuration that existed when the storage register was selected. This means the instrument is once again configured to make TRFL measurement at the previously calibrated frequency. (Keep in mind that calibration is not source dependent; that is, once the HP 8902A has been calibrated at a given frequency it can be used to measure your other signal sources set at the same frequency as well.)

Noisy Signal

If the input signal is noisy, unstable, or has greater than 100 Hz FM, the narrow-band IF Synchronous detector may have difficulty remaining locked to the input signal. The instrument will indicate that the input signal is not stable enough for the IF Synchronous detector to tune to by continuously displaying six dashes, or by alternating six dashes then four dashes in its display. To measure the TRFL of noisy signals, select the wider-band IF Average detector by keying in **4.4 SPCL**. After the IF Average detector is selected, the calibration procedure is the same as for the IF Synchronous detector (as shown in **Calibration** in this chapter). (Note that the IF Average detector must be selected prior to calibrating Range 1.) The measurement bandwidth of the IF Average detector is determined by the IF filter selected (refer to **Increasing Selectivity** for filter information).

For added noise correction when using the IF Average detector to measure low-level signals, key in **31.1 SPCL*** when you select the IF Average detector (that is prior to calibrating Range 1). (This function should only be used when a Sensor Module is being used with the HP 8902A.) This function causes the instrument to create an additional calibration factor for Range 3 (-60 to -100 dBm) which it uses to compensate for any residual noise inherent within the measurement system.

The noise correction function (31.1) is maintained through instrument power down. To turn off noise correction, key in **31.0 SPCL**.

* This capability is available on instruments serial prefixed 2535A and above.

Drifty Signal

If the input signal is drifting, the IF Synchronous detector may have difficulty remaining locked to the input signal. The instrument will indicate that it is having difficulty by placing six dashes or Error 01 in its display.

The wider measurement bandwidth of the IF Average detector makes it more tolerant of signal drift. Press the green **AUTOMATIC OPERATION** key and then key in **4.4 SPCL** to select the IF Average detector for your TRFL measurements. (Note that the Track Mode function is not available for TRFL measurements.)

Frequency Overrange

There are three techniques for extending the HP 8902A's frequency range above 1300 MHz; internal harmonic mixing, external local oscillator and mixer down conversion, and down-conversion with a spectrum analyzer. All three techniques extend the measurement capabilities of the HP 8902A to microwave frequencies. Refer to *Chapter 5* for measurement examples using these tuning techniques.

Frequency Underrange

The specified low frequency limit of the TRFL measurement is 2.5 MHz. However, you can extend this measurement range to approximately 900 kHz; the procedure is simple. Connect your signal source to the HP 8902A and adjust the source level to between 0 and -20 dBm. Press the **Blue Shift** key and the **INSTR PRESET** key on the HP 8902A. Manually tune the HP 8902A to 5 MHz. When Error 01 is displayed, select the TRFL measurement. Manually tune the HP 8902A to the frequency of the input signal. When the signal level is display, proceed with TRFL calibration.

Low-Level Signal

To measure the TRFL of a signal source that can not be set to a level between 0 and -20 dBm, simply use a second signal source whose level can be set between 0 and -20 dBm to perform the calibration procedure. Connect the HP 8902A to the second signal source and adjust the signal source frequency to the frequency of the signal to be tested. After you have completed the calibration procedure using the second source, reconnect the HP 8902A to the signal source to be tested and measure its TRFL.

Input Impedance

To improve the SWR characteristics of your TRFL measurements, an internal, fixed 10 dB pad can be inserted at the INPUT of the HP 8902A. Inserting this pad enables the HP 8902A to maintain a constant input impedance over its entire measurement range. Key in **1.9 SPCL** to insert the fixed 10 dB pad. (Note that the SPCL key does not remain lit.) The instrument continues to operate in its Automatic Operation mode except that the 10 dB pad is now always inserted. (Note that Special Function 1.9 decreases the sensitivity of Range 3 by 10 dB.)

Help

If You Need to Know:	Refer to:
<u>Setup</u>	
<ul style="list-style-type: none"> • <i>How to change to another Sensor Module</i> 	<p>Changing Sensor Modules (4-10)</p>
<ul style="list-style-type: none"> • <i>How to measure RF Power or TRFL without using a Power Sensor</i> 	<p>No Power Sensor (4-11)</p>
<ul style="list-style-type: none"> • <i>How to automate your RF Power or TRFL measurements</i> 	<p>HP-IB (4-12)</p>
<ul style="list-style-type: none"> • <i>How to connect an external time base</i> 	<p>Time Base (4-12)</p>
<u>Measurement</u>	
<ul style="list-style-type: none"> • <i>Which measurement to choose for your application</i> 	<p>RF Power vs TRFL (4-12)</p>
<ul style="list-style-type: none"> • <i>How to interpret an error code, dashes or questionable measurement</i> 	<p>Solving Measurement Problems (4-13)</p>

Changing Sensor Modules

Long Term

If you are replacing the Sensor Module with another Sensor Module, refer to *Appendix B* in this guide for the procedure for entering the calibration data for the new Sensor Module into the HP 8902A.

Short Term

If you are only using the new Sensor Module temporarily, you can manually enter the appropriate cal factor for each RF Power measurement. (Refer to your HP 8902A Operation and Calibration Manual for the procedure and considerations for manually entering cal factors.)

Interchangeably

If you plan to use two sensors interchangeably, a second storage table is available in the HP 8902A's non-volatile memory. This table is designed to be used in the instrument's Frequency Offset Mode. (In this mode an external local oscillator (LO), a microwave down-converter, and a mixer are typically used to extend the frequency range of the HP 8902A. Refer to your HP 8902A Operation and Calibration Manual for details on using the Frequency Offset Mode.)

By specifying an offset frequency of zero, the Frequency Offset table can also be accessed for measurements when an external LO is not being used. Simply key in **27.3 SPCL** and then **0 MHz** (the fOFS annunciator will light in the display). The instrument is now ready to store the calibration factors (up to 22) for the second Sensor Module in the Frequency Offset table using the entry procedure shown in *Appendix B*.

Once the cal factors have been stored, key in **27.0 SPCL** when you wish to exit the Frequency Offset Mode and use the first Sensor Module. To re-enter the Frequency Offset Mode and use the second Sensor Module, key in **27.1 SPCL**.

No Power Sensor

RF Level (uncalibrated)

To make an uncalibrated RF power measurement without a power sensor, connect a 50 Ω cable and Type-N connector from the HP 8902A's INPUT port to the output of your signal source. Press the **RF POWER** key. The HP 8902A will make an uncalibrated broadband power measurement using its RF Peak detector. (Note that the HP 8902A lights the **SPCL** key rather than the **RF POWER** key when it is using the uncalibrated RF Peak detector to measure power.) Although the accuracy of this measurement is significantly lower than a calibrated power measurement made using a power sensor, it can be useful as a means of determining if there is any input signal present at the HP 8902A's input. If a Sensor Module is connected to the HP 8902A, the RF Peak detector can be selected by keying in **35.0 SPCL**.

Tuned Level (uncalibrated)

To make an uncalibrated Tuned Level measurement (either with a Sensor Module connected to the HP 8902A or with a BNC cable and Type-N connector connected at the INPUT port) tune the HP 8902A to the frequency of the input signal and key in **36.0 SPCL**. The HP 8902A will make an uncalibrated Peak Tuned Level measurement. Although the accuracy of this measurement is significantly lower than a calibrated TRFL measurement, it can be useful for measuring input signals that are drifting.

TRFL (calibrated)

The relative power measurement mode (SET REF) allows you to make calibrated TRFL measurements without using a power sensor. An example of this measurement technique is provided in *Chapter 5*.

HP-IB

The HP 8902A enables you to fully automate your RF Power and TRFL measurements. Refer to your HP 8902A Operation and Calibration Manual for set up and programming information.

Time Base

A time base input is provided on the rear panel of the HP 8902A. This input allows you to connect the HP 8902A to an external 10 MHz time base reference. The time base circuitry within the HP 8902A automatically switches to the external time base and turns off its time base output when an external time base of sufficient amplitude (0.5 Vpp) is applied at the input. To verify that an external time base is being used, key in **15.1 SPCL**. The instrument will display a 1 if the external time base is being used or a 0 if the internal time base is being used.

RF Power vs TRFL**Bandwidth**

The fundamental difference between the RF Power and TRFL measurement is their measurement bandwidth. The measurement bandwidth for the RF Power measurement is set by the bandwidth of the power sensor being used. For instance, the measurement bandwidth of the power sensor used in the HP 11722A Sensor Module is 4 GHz, therefore the RF Power measurement bandwidth of the HP 8902A is 4 GHz when used with the HP 11722A. Select the RF Power measurement when you wish to measure total power of all modulation, sidebands, harmonics, and spurious on the signal (as you would using an HP 436A or HP 438A type power meter).

The measurement bandwidth of the TRFL measurement is much narrower than that of the RF Power measurement. When the IF Synchronous detector is used to make a TRFL measurement, measurement bandwidth is 200 Hz.

When the IF Average detector is selected, measurement bandwidth is determined by the bandwidth of the IF filter being used (30 kHz or 200 kHz). (The 30 kHz filter is automatically chosen by the instrument when the IF Average detector is selected; refer to **Increasing Selectivity** in this chapter for filter selection information.) The IF Average detector measures the total power of the signals and noise present within the IF filter passband. Select the TRFL measurement mode when you want to make calibrated tuned level measurements of discrete input signals.

Sensitivity

The most apparent difference between the TRFL measurement and the RF Power measurement is the increased measurement sensitivity offered by the TRFL measurement. Since sensitivity is directly related to measurement bandwidth, TRFL measurements using the IF Synchronous detector offer the greatest measurement sensitivity (-127 dBm). When you select the IF Average detector for your TRFL measurements, measurement sensitivity is determined by the bandwidth of the selected IF filter. That is, the 30 kHz IF filter offers 8 dB greater sensitivity than the 200 kHz IF filter. (The IF Average detector offers -100 dBm measurement sensitivity with the automatically selected 30 kHz filter.)

Like other RF power meters, the sensitivity of the HP 8902A's RF Power measurement is determined by the dynamic range of the power sensor being used. The dynamic range of the HP 11722A Sensor Module, for instance, is -20 to +30 dBm. Using other sensors, the sensitivity of the HP 8902A's RF Power measurement can be extend from -70 to +40 dBm. (Refer to your HP 8902A Operation and Calibration Manual for information on which power sensors can be used with the HP 8902A.)

Solving Measurement Problems

The HP 8902A has been designed to feedback information about its operating status. When the HP 8902A detects that the input signal or operating conditions are preventing it from making an accurate, reliable measurement, it alerts you by placing an error or dash code in its display. The circumstances that can cause the HP 8902A to display an error code are classified into one of two categories:

- **Input Problem** - caused by input signal conditions, or
- **Operating Problem** - caused by the selection of incompatible operating functions.

Certain errors are caused *only by an input problem*, other errors are caused *only by an operating problem*, and some errors can be caused by either.

The errors that can be caused *only by an input problem* and the errors that can be caused *only by an operating problem* are listed in the following chart.

If your instrument is displaying one of these errors, proceed directly to **Table 4-3. RF Power and TRFL Error Codes** and take the recovery action recommended.

	Input Problem	Operating Problem
Error	08, 10, 13, 34 or 35	01, 09, 12, 14, 15, 18 thru 32

If you did not find your error listed in the chart, or if your instrument is displaying dashes or a questionable measurement, perform the following procedure.

1. Press the green **AUTOMATIC OPERATION** key. This cancels all function settings that can cause the HP 8902A to display an error code.
2. Compare the operating status of your HP 8902A after pressing the **AUTOMATIC OPERATION** key with the conditions described below. After you have identified the description that best fits your instrument's condition, take the action recommended for that condition.

Same Error

If the error or reading remains the same after the **AUTOMATIC OPERATION** key has been pressed, the error is being caused by an input problem. Look up the error code in Table 4-2 and take the action recommended for "Input Problem".

No Error

If the error goes away after the **AUTOMATIC OPERATION** key has been pressed, the error was caused by an operating problem. Look up the error code in Table 4-2 and take the action recommended for "Operating Problem".

New Error

If the error is replaced by a different error or dash code after the **AUTOMATIC OPERATION** key has been pressed, the original error was being caused by a combined input problem and operating problem. Look up the error code displayed by the instrument *after* the **AUTOMATIC OPERATION** key was pressed. Take the action recommended for "Input Problem".

Remember

Because of the wide variety of input signals and the operating flexibility of the HP 8902A, it is not possible to list all recovery actions for each error code. After using the table to determine the cause of the problem, you may discover other recovery procedures that are better suited to your application.

Table 4-3. RF Power and TRFL Error Codes (1 of 2)

Display Code	Problem Description	Input Problem	Operating Problem
Questionable Measurement	1. Measurement is very inaccurate 2. Measurement is slightly inaccurate.	1. Check tuning. Refer to <i>Tuning (4-7)</i> and <i>Increasing Selectivity (4-7)</i> . Check signal source. 2. Check RF Power calibration (4-2)	Recheck operating conditions being used.
--	Instrument is unable to find an input signal.	Set input signal level to between 0 and -20 dBm, and check tuning. Refer to <i>Tuning (4-7)</i> .	
----	Instrument has detected an input signal and is attempting to set up measurement. Continuous display indicates instrument is having difficulty tuning to input signal	Manually tune to input signal. Refer to <i>Noisy Signal (4-8)</i> and <i>Drifty Signal (4-9)</i> .	Re-check operating conditions being used.
-----	IF Synchronous Detector is searching for input signal. Continuous display (>30 sec) may indicate unstable input signal or incorrect tuning.	Check tuning. Refer to <i>Tuning (4-7)</i> , <i>Noisy Signal (4-8)</i> , and <i>Drifty Signal (4-9)</i> .	Re-check special operating conditions being used.
01	IF signal within IF passband but not centered well enough to guarantee measurement accuracy (due to manual tuning).		Ensure that the level of the input signal remains stable during TRFL calibration. If problem persists, signal may be drifting. Refer to <i>Drifty Signal (4-9)</i> .
02	Input circuits overdriven.	Decrease level of input signal.	Decrease selected RF and/or IF gain setting.
03	Input circuits underdriven.	Increase level of input signal.	Decrease selected RF input attenuation or increase IF gain. If Range Hold is being used, check range limits.
06	TRFL - Input level exceeds 7 Vrms (1W peak), or RF amplifier selected with >0 dBm at input. RF Power - Input level exceeds measurement range of power sensor being used.	Decrease level of input signal and press the CLEAR key.	Decrease selected RF or IF gain. If Range Hold is being used, check range limits.
07	Voltmeter is being overdriven.	Decrease level of input signal and press the CLEAR key.	Decrease selected RF or IF gain. If Range Hold is being used, check range limits.
08	Calibrator output not sensed at INPUT.	Check connection to Calibrator. Check for Calibrator malfunction.	
09	High stability time base problem (Option 002 instruments only).		Check internal time base for malfunction.
10	Frequency of input signal is not within measurement range. TRFL circuits being overdriven.	Set the input level to between 0 and -20 dBm. Select the Frequency mode. When the instrument displays the frequency of the input signal, press the MHz key and re-enter the TRFL mode.	
11	1. Attempting to measure RF power (dBm) with no power at sensor input. 2. Mathematics error (log 0 not allowed).	1. Select linear (Watts) units, or disregard error when there is no power present at sensor input.	2. Key in a different ratio reference.

Table 4-3. RF Power and TRFL Error Codes (2 of 2)

Display Code	Problem Description	Input Problem	Operating Problem
12	Indicates internal time base oven cold (Option 002 instruments only).		Wait for oven to warm for highest accuracy.
13	Power sensor was disconnected during RF Power measurement.	Secure connection at SENSOR input.	
14	Cannot zero power sensor.		Remove power from power sensor input during zeroing process.
15	Indicates Sensor Module's Reference Calibration Factor not stored in instrument.		Refer to <i>Appendix B</i> for entry and verification information.
17	IF level not within its measurement range.	Input signal level during reference measurement must be between 1.25V and 2.50V. (Option 030 only.)	Check selected RF or IF gain level. (When making Ratio measurements, allow instrument to complete the reference measurement.)
18	Indicates power level at Sensor Module input is not 0.0 dBm (1 mW) during calibration process.		Check sensor connection at RF POWER OUTPUT port.
19	TRFL circuits underdriven.		Increase IF gain.
20	Entered value out of range.		Check limits of function.
21	Invalid key entry.		Check compatibility of function(s) with selected measurement mode.
22	Invalid special function prefix entered.		Check special function number and re-enter.
23	Invalid special function suffix entered.		Check special function number and re-enter.
24	Invalid HP-IB code.		Check function codes.
25	Selected special function not compatible with measurement mode.		Check special function combination compatibility with measurement.
26	End of RF Power calibration table. (If displayed after first attempt to read table using 37.6 SPCL, the table is empty.)		Refer to <i>Appendix B</i> for cal factor entry and verification procedures.
30	Inappropriate RF attenuation or gain setting due to selected special functions or Range Hold function.		Change RF attenuation and gain or Range Hold setting.
31	RF Power calibration necessary in order to perform TRFL calibration.		Refer to <i>RF Power Calibration</i> in Chapter 1.
32	Inappropriate IF gain setting due to selected special functions or Range Hold function.		Change IF gain or Range Hold setting.
33	Instrument unable to make RF Power reference measurement during TRFL calibration.	Maintain stable frequency and level during calibration. Check SENSOR connection.	Check RF Power calibration. Refer to <i>RF Power</i> in Chapter 1.
34	Input signal lost during TRFL calibration.	Maintain stable frequency during TRFL calibration.	
35	Input signal level unstable during TRFL calibration.	Use a stable signal source for TRFL calibration.	

5

Measurement Examples

In This Chapter

This chapter contains examples of measurement applications using the HP 8902A. The intent of this chapter is to demonstrate the flexibility of the HP 8902A's measurement capability. (To perform the measurements, an understanding of the HP 8902A's basic operating capabilities as described in *Chapter 1* is necessary.)

This chapter enables you to reference directly to the measurements you are interested in. The examples are organized into the three measurement groups.

- RF Frequency and Frequency Error measurements
- Modulation and Audio measurements
- RF Power and Tuned RF Level (TRFL) measurements

The Directory

Use the directory diagram below to quickly locate the measurement you are interested in. A look-up table is located on the first page of each measurement group. Use the look-up table to reference to the examples provided for that group.

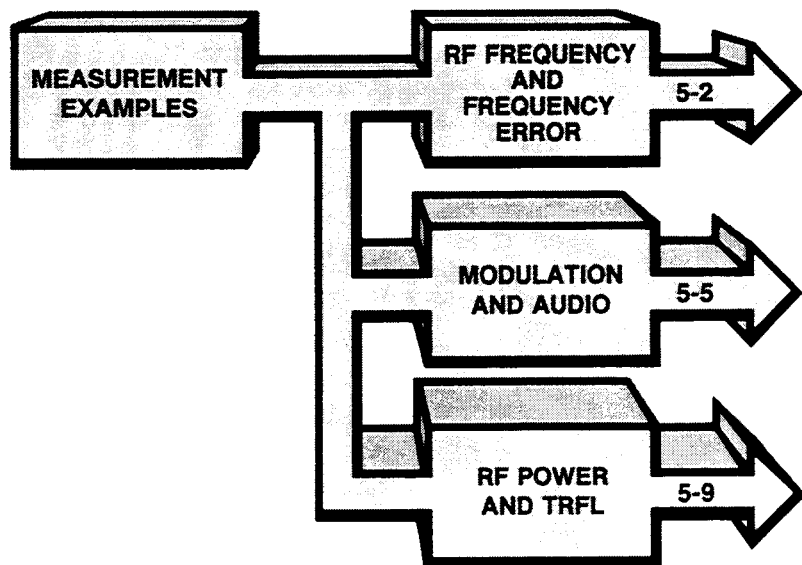

RF Frequency and Frequency Error

If you need to know:	Refer to:
• A convenient way to set up low-level frequency measurements	Low-Level Frequency (5-2)
• A way to accurately characterize the frequency response of an RF device .	Output Flatness (5-3)
• A way to quickly measure multi channel transmitters	Multi channel Testing (5-3)
• A way to measure frequency accuracy in parts-per-million (PPM)	Frequency Error (PPM) (5-4)
• A way to measure signals above 1300 MHz using an external LO mixer	Frequency Offset Mode (5-4)

Low-Level Frequency

Here is a convenient way to measure the frequency stability of low-level signals, below -60 dBm (remember that the Manual Tuning mode provides measurement sensitivity to -60 dBm). You may remember that in *Chapter 2* the special function codes were given for setting up the instrument for low-level RF frequency measurements. This procedure allows the instrument to automatically select the appropriate special function settings for you.

1. **Set the signal source to the desired output frequency and connect it to the HP 8902A.** Adjust the output level of the source to between 0 and -20 dBm. (If the source under test cannot be adjusted to between 0 and -20 dBm, use a second source that can be adjusted to perform the TRFL measurement first.)
2. **Manually tune the HP 8902A to the frequency of the input signal and then select the TRFL measurement.** In the TRFL mode, the instrument automatically selects the appropriate measurement range settings for low-level measurements.
3. **Decrease the input signal to the level at which you wish to make the frequency measurement.** It is not necessary to calibrate the TRFL measurement if you are only interested in making an RF frequency measurement.
4. **When the HP 8902A displays the input signal level at which you wish to measure frequency accuracy, press the RANGE HOLD key on the HP 8902A.**
5. **Select the Frequency measurement on the HP 8902A.** (If you wish to check frequency error, select the Frequency Error measurement.)

Output Flatness

The following procedure demonstrates a way to use the HP 8902A to characterize the frequency response of RF devices. This technique enables you to accurately characterize output flatness from 100 kHz to 2.6 GHz at levels between -20 and +30 dBm.

1. **Connect the HP 8902A and Sensor Module to the output of your RF signal source.** Adjust the source to the frequency at which you wish to establish the reference level.
2. **Select the RF Frequency measurement and press the green AUTOMATIC OPERATION key on the HP 8902A.**
3. **When the HP 8902A displays the frequency of the input signal, select RF Power on the HP 8902A.** The previous frequency measurement enables the instrument to automatically select the correct calibration factor for its power measurement. (Use the LOG/LIN key if you wish to toggle between Watts and dBm units.)
4. **Press the RATIO key.** This establishes the current measurement level as the reference level.
5. **Change the frequency of the signal source, and re-select the RF Frequency measurement on the HP 8902A.**
6. **When the HP 8902A displays the input frequency, select RF Power.**
7. **Press the Blue Shift key and then the PREVIOUS RATIO (RATIO) key** to reference this measurement to the reference level previously set in step 4.
8. **Repeat steps 5, 6 and 7 to check output flatness across the output frequency range of your device.**

Multi-channel Testing

Use the HP 8902A to quickly measure an evenly spaced multi-channel transmitter (such as a CB radio).

1. **Adjust the transmitter to its first (lowest) channel and connect its output to the HP 8902A.**
2. **Select the desired measurement on the HP 8902A and manually tune it to the frequency of the transmitter's first channel.** If the HP 8902A displays Error 01 (IF Frequency not centered), key in 8.1 SPCL to disable the error so you can read the measurement.
3. **Key an increment value into the HP 8902A equal to the channel spacing of the transmitter and then press \uparrow kHz key.** (For example, press the digit keys 25 and then the \uparrow kHz key to increment in 25 kHz steps.) From now on just press the \uparrow kHz key each time you want to increment up by 25 kHz.
4. **Adjust the transmitter to its next channel.** The HP 8902A will display the measured value for the next channel. (Press the Blue Shift key and the DISPLAY FREQ key if you wish to check the HP 8902A's tune setting.)
5. **Continue to adjust the transmitter and then increment the HP 8902A to check each of the remaining channels.**

Frequency Error (PPM)

The HP 8902A's Ratio Mode allows you to verify frequency accuracy specifications given in parts-per-million.

1. Connect the HP 8902A to the output of your signal source, and manually tune the HP 8902A to the expected output frequency of the source.
2. Select Frequency Error on the HP 8902A. To increase display resolution to 10 Hz, key in 7.1 SPCL.
3. Key one-tenth the manually tuned input frequency value (from step 1) into the HP 8902A and then press the **RATIO** key. (For example, if the manually tuned frequency was 179.0 MHz, you would key in 17.9 and then press the **RATIO** key.)
4. The HP 8902A is now displaying frequency error in parts-per-million.

Frequency Offset Mode

This procedure demonstrates how the HP 8902A's Frequency Offset Mode allows you to measure input signals above 1300 MHz using an external oscillator and mixer. (This is one of three techniques available for extending the RF frequency range of the HP 8902A. The other two are also shown in this chapter.) Diagram 5-1 shows the setup for this down-conversion technique.

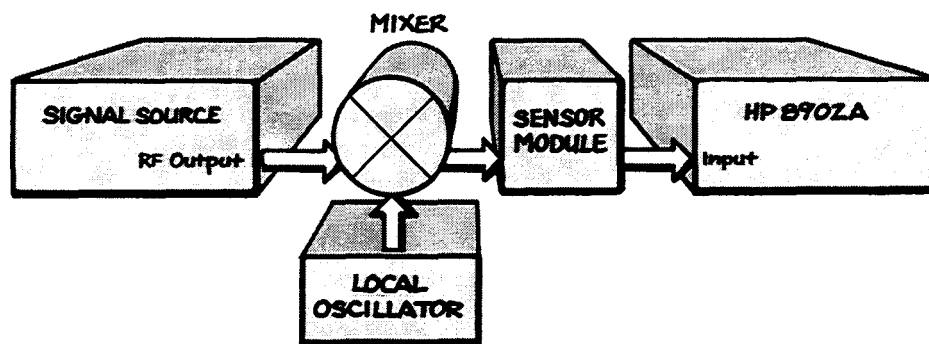

Diagram 5-1. Setup for Frequency Down Conversion

1. Set the signal source to the desired frequency at an amplitude of about -5 dBm. (The optimum level will depend on the mixer being used; select a level that will prevent mixer compression.)
2. Set the external LO to equal the output frequency of the signal source plus 120.53 MHz. (For instance, if the signal source frequency was 2.5 GHz, the LO should be set to 2620.53 MHz.) This positions the HP 8902A's internal IF in the center of a tuning octave.
3. Set the output level of the external LO to $+8$ dBm.
4. Press the **AUTOMATIC OPERATION** key and then key in 27.3 SPCL, the external LO frequency, and the MHz key on the HP 8902A. If you make a mistake, press the **CLEAR** key and re-enter the keystrokes.

5. Manually tune the HP 8902A to the expected frequency of the signal source by keying in the source frequency and then pressing the MHz key. The Manual Tuning Mode is always the right choice for this measurement technique.
6. Now select the desired measurement on the HP 8902A. If you are making RF Power or Tuned RF Level measurements, the calibration factors for the Sensor Module that you are using need to be stored in the Frequency Offset cal factor storage table. Refer to *Appendix B* for the storage procedure.
7. When you want to exit the Frequency Offset Mode, key in 27.0 SPCL. If you wish to re-enter the Frequency Offset Mode and maintain the same external LO frequency set in step 4, key in 27.1 SPCL.

Modulation and Audio

If you need to know:	Refer to:
• A way to measure FM bursts	Tone Burst FM (5-5)
• An easy way to measure the residual modulation of a transmitter	Residual Modulation (5-6)
• A way to measure SINAD on internally demodulated or external audio signals	SINAD (5-7)
• A quick way to measure signal-to-noise	Signal-to-Noise (5-7)
• A way to use the Ratio Mode to check modulation flatness	Modulation Flatness (5-8)
• A way to measure frequencies above 1300 MHz using a spectrum analyzer as a fixed-tuned receiver	SA Down-Conversion (5-8)

Tone Burst FM

This procedure enables you to configure the HP 8902A as a Tone Burst receiver by setting a time delay between when the HP 8902A senses an RF signal at its INPUT and when it enables the output at the MODULATION OUTPUT/AUDIO INPUT port.

1. Connect your transmitter (modulated source) to the HP 8902A's INPUT. Connect an audio counter to the MODULATION OUTPUT/AUDIO INPUT port.
2. Press the FM key on the HP 8902A.
3. Select a detector, and if desired, Audio Filters, and an FM De-Emphasis filter.
4. Key on the transmitter. Allow the HP 8902A to range and tune automatically.

5. Press the **RANGE HOLD** key to hold all ranges and tuning.
6. Key in **18.NN SPCL** to set the time delay. Where NN equals the desired delay in milliseconds (from 1 to 99). (For instance, if a 5ms delay is desired, enter 18.5 SPCL, if a 50ms delay is desired, enter 18.50 SPCL.) The special function value will remain in the display.
7. Key on the transmitter. The audio counter should display the modulation rate present at the end of the delay period.

Residual Modulation

Residual modulation is a measure of the hum and noise of the unmodulated transmitter. For FM mobile transmitters, hum and noise is defined as the ratio of the output of a standard receiver with de-emphasis when the transmitter is modulated and then unmodulated. (Hum and noise is usually expressed in dB referenced to 3 kHz peak deviation.)

1. Connect your transmitter to the HP 8902A and turn off FM modulation.
2. Press the **50 Hz HP filter** key. The 50 Hz high-pass filter is recommended for this measurement. The HP 8902A's residual FM is low enough that it can measure the hum and noise of most transmitters directly. Diagram 5-2 shows the typical residual FM characteristics for the HP 8902A.
3. Press the **PRE-DISPLAY** key and then the **750 μ s** key. The 750 μ s filter attenuates a 1 kHz signal by 13.66 dB (a factor of 0.2076).
4. Press the **FM** key on the HP 8902A to measure residual FM.
5. Press the **Blue Shift** key and the **RMS (AVG)** key. This selects the true RMS detector.
6. Key in **.44** and then the **RATIO** key. For standard modulation, the ratio reference is 0.440 (that is, $3.0 \times 1/\sqrt{2} \times 0.2076 = 0.440$).
7. Use the **LOG/LIN** key to select **dB** units. The display now indicates FM hum and noise in dB relative to 3 kHz peak deviation.

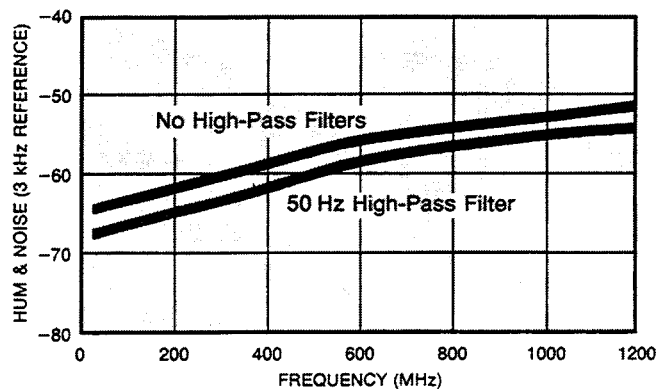
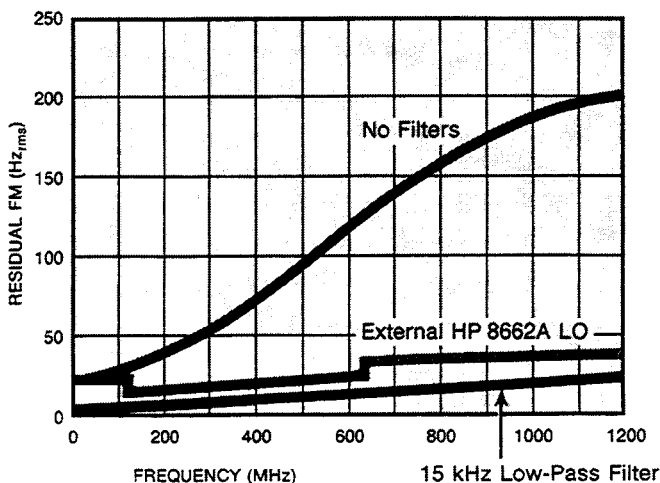

Diagram 5-2. Typical HP 8902A Residual FM Characteristics

SINAD The HP 8902A allows you to make SINAD measurements (at 1 kHz or 400 Hz) on the internally *demodulated audio* signal or on an *external audio* signal applied to the MODULATION OUTPUT/AUDIO INPUT port.

Demodulated Audio

1. Connect your modulated signal source to the HP 8902A's INPUT port.
2. Select the appropriate modulation mode (AM, FM or Φ M).
3. Key in 29.0 SPCL, the Blue Shift key, and then the 1 kHz DISTN (PEAK+) or 400 Hz DISTN (PEAK-) key. An annunciator in the display indicates which frequency is being measured.
4. Use the LOG/LIN key if you wish to toggle between % and dB units.
5. Press the appropriate Audio Filter keys to set the desired measurement bandwidth for the internally demodulated audio signal.

External Audio

6. Connect your audio source to the MODULATION OUTPUT/AUDIO INPUT port on the HP 8902A.
7. Press the AUDIO INPUT key (key should remain lit).
8. Perform steps 3 and 4 above to measure the SINAD of the external audio signal.

Signal-to-Noise

The HP 8902A's Ratio Mode makes it easy to make relative measurements such as signal-to-noise on AM transmitters or hum and noise on FM transmitters.

1. Connect your signal source to the INPUT port on the HP 8902A and turn the modulation off.
2. Select the appropriate modulation measurement on the HP 8902A, (AM, or FM) and the RMS detector.
3. Press the **RATIO** key to establish the unmodulated input signal as the reference measurement.
4. Press the LOG/LIN key if you wish to toggle between % and dB units.
5. Turn on the modulation at the modulation source. The HP 8902A will compute and display the signal-to-noise ratio.

Modulation Flatness

The HP 8902A's Ratio Mode makes it easy to make relative measurements such as modulation flatness.

1. **Connect your modulated source to the HP 8902A's INPUT.**
2. **Select the appropriate modulation measurement on the HP 8902A, (AM, FM, or Φ M).**
3. **Key in a reference modulation and press the **RATIO** key.** (For instance, press 3 and then the **RATIO** key to establish a reference of 3% AM depth, or 3 kHz FM deviation.) Or, simply press the **RATIO** key by itself to establish the signal present at the HP 8902A's INPUT as the reference.
4. **Press the **LOG/LIN** key if you wish to toggle between % and dB units.**
5. **Vary the modulation rate of your source across the audio spectrum.** The HP 8902A will display modulation flatness as the change in measured modulation relative to the reference.

SA Down-Conversion

The measurement range of the HP 8902A can be extended above 1300 MHz for modulation and audio frequency measurements by using a spectrum analyzer as a fixed-tuned receiver. (This is one of three techniques available for extending the RF frequency range of the HP 8902A. The other two are also shown in this chapter.)

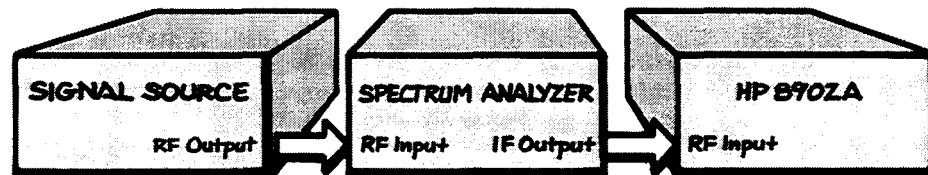

1. **Connect the signal source, spectrum analyzer and HP 8902A as shown above.**
2. **Tune the spectrum analyzer to the output frequency of the signal source.** Set the spectrum analyzer in its zero span mode with linear detection, and select a resolution bandwidth that is wide enough to pass the input signal (e.g. 3 MHz).
3. **Adjust the spectrum analyzer fine frequency control to peak the signal on the spectrum analyzer display.**
4. **Tune the HP 8902A to the IF output frequency of the spectrum analyzer and select the desired modulation or audio measurement.** (Note that residual FM measurements will generally be limited by the phase noise characteristics of the spectrum analyzer's local oscillator.)

RF Power and TRFL

If you need to know:	Refer to:
• A way to use the SET REF mode for attenuator testing	Attenuator Testing (5-9)
• A way to measure low-level signals that can not be adjusted to between 0 and -20 dBm	Low-Level Signals (5-10)
• A way to measure a noisy signal source using the IF Synchronous detector ...	Noisy Source (5-11)
• A way to measure frequencies above 1300 MHz using harmonics of the HP 8902A's LO	Harmonic Mixing (5-11)

Attenuator Measurement

This measurement technique will enable you to measure the relative level change of devices, such as attenuators, directly and accurately.

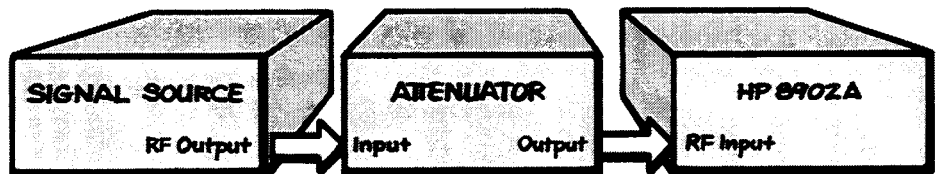

Diagram 5-3. Attenuator Measurement Setup

1. Tune the signal source to the desired frequency.
2. Set the level of the output signal from the device under test to 0 dBm and connect it to the HP 8902A.
3. When the HP 8902A displays the input signal frequency, press the MHz key, the gold S key, and then the Tuned RF Level key on the HP 8902A.

4. **After the measurement has settled, press the Blue Shift key and the SET REF (ZERO) key.** This establishes the current input level as the 0 dB reference for the TRFL measurement. Note that the RECAL and UNCAL annunciators are now off.
5. **Press the LOG/LIN key if you wish to toggle between % and dB.**
6. **Begin stepping down the output level of the device under test by increments of 10 dB or less.** Press the CALIBRATE key each time the RECAL annunciator is displayed.
7. **When you want to exit the relative measurement mode, key in 26.0 SPCL.** Key in 26.1 SPCL if you wish to re-enter the relative measurement mode and continue to use the previously established 0 dB reference.

Low-Level Signals

This procedure will enable you to measure low-level signals that can not be adjusted to between 0 and -20 dBm (such as spurs) down to -110 dBm; even in the presence of larger signals as close as 2 MHz. This example also demonstrates how the Store and Recall functions help you quickly repeat TRFL measurements at various frequencies.

1. **Connect the HP 8902A to a signal generator and adjust its output to 0 dBm at the frequency of the spurious signal.**
2. **Manually tune the HP 8902A to the input signal and perform the TRFL calibration.** Performing TRFL calibration is actually optional. If you do not perform the calibration, the HP 8902A will make uncalibrated measurements with approximately ± 1.5 dB accuracy.
3. **When the TRFL calibration is complete, return the signal generator level to between 0 and -20 dBm.**
4. **Press the Blue Shift key, the STORE (7) key, and the 1 digit key.** This stores the current frequency setting and calibration data in register 1. Repeat steps 1 through 3 at the frequency of each spur to be tested (up to eight). (If you wish to check more than eight frequencies, use an external controller and the 38.N special functions to create a TRFL calibration factor data base and the 39.N special functions to re-enter the calibration factors as they are needed to check each frequency.)
5. **Connect the HP 8902A to the spur source, and press the Blue Shift key, the RECALL (8) key and the 1 digit key.** This causes the instrument to recall the frequency setting and TRFL calibration data stored in register 1. The HP 8902A now automatically ranges to and displays the level of the spur. Press the LOG/LIN key if you wish to toggle between Watts and dBm units.

Noisy Source

Diagram 5-4 shows how to set-up TRFL measurements for an extremely noisy signal source. Using this setup, signal levels with many MHz of residual FM deviation can be measured to -100 dBm.

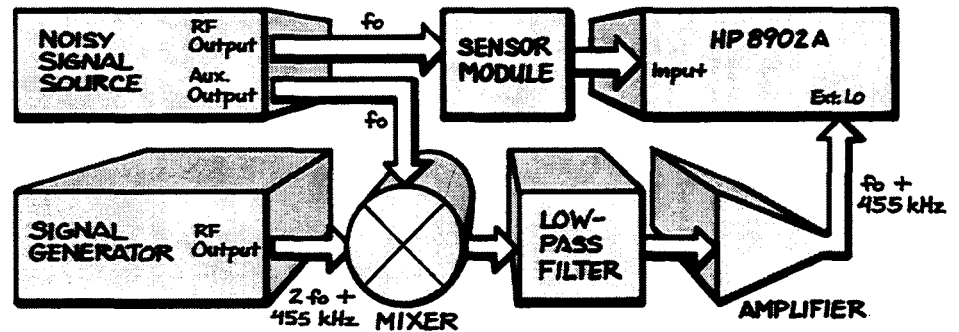

Diagram 5-4. Setup for Measuring the TRFL of an Extremely Noisy Source.

The only requirement on the signal source is that it have an auxiliary output. The auxiliary output is down-converted and substitutes as the local oscillator (LO) for the HP 8902A. With this setup, the same residual FM, drift, or instability present at the signal source output is also present on the LO input to the HP 8902A. This enables the IF Synchronous detector in the HP 8902A to automatically track the noisy input signal.

Harmonic Mixing

In normal operation, the HP 8902A uses the fundamental mixing of its internal local oscillator (LO) to make measurements to 1300 MHz. You can extend the measurement range to 2.1 GHz by using harmonic mixing of the internal LO. (Because harmonic mixing produces higher conversion loss, measurement sensitivity begins to degrade above 1300 MHz to -105 dBm at 2.1 GHz.) This is one of three techniques available for extending the RF frequency range of the HP 8902A. The other two are also shown in this chapter.

1. Connect the HP 8902A to the signal source and set the source level to between 0 and -20 dBm. Disregard Error 10 if it is displayed.
2. Press the Blue Shift key, the INSTR PRESET key, the gold S key, and the TUNED RF LEVEL key.
3. Key in 3.6 SPCL to select the narrow-band 455 kHz IF filter.
4. Press the Blue Shift key and the DISABLE ERROR (RANGE HOLD) key to disable Error 01 if it remains in the display.
5. Manually tune the HP 8902A to a frequency equal to 0.30333 MHz less than one third of the signal to be measured. (For example, to tune to a 2100 MHz signal, manually tune the HP 8902A to 699.6867 MHz: $(2100/3) - 0.30333 \text{ MHz} = 699.6967 \text{ MHz}$.)
6. Decrease the level of the input signal and perform the TRFL calibration. Press the LOG/LIN key if you wish to toggle between Watts and dBm units.

A

Installation

Unpack Your HP 8902A

Inspect the shipping container for damage. If the shipping container is damaged or the cushioning material inside is stressed, keep them until you have checked the shipment for completeness and proper operation.

If components are missing from your shipment, or if there is mechanical damage or defect, notify the nearest Hewlett-Packard office. If the shipping container or cushioning material shows signs of stress, notify the carrier as well as the Hewlett-Packard office. Keep the shipping materials for inspection by the carrier.

Connect Power

If you are not sure of the power or fuse requirements for your instrument, refer to *Section 2* of the HP 8902A Operation and Calibration Manual for further information.

Connect the Sensor

Connect the Sensor Module to the SENSOR and INPUT ports. (Refer to *Appendix B* in this guide for information on configuring the HP 8902A to operate with your Sensor Module.)

Turn On Instrument

If you are operating this instrument in extreme environmental conditions, refer to *Section 2* of the HP 8902A Operation and Calibration Manual for specific operating limitations.

B

Calibration Factors

What to Do

The calibration data for the Sensor Module you are using must be entered into the HP 8902A before it can make calibrated RF Power measurements. To determine the appropriate action to take, find the description below that best describes your circumstances and take the action recommended.

Descriptions

New HP 8902A (Option 021, E02, or E04) or HP 8902S

If your HP 8902A and Sensor Module were ordered together as an Option 021, E02, E04, or as part of a system, the calibration factors for the Sensor Module have already been entered into the HP 8902A. (You can return to *Chapter 1* to begin making measurements with the HP 8902A.)

No Cal Factors Entered (Error 15)

If the HP 8902A displays Error 15 when you press the RF Power key, no cal factors have been entered. Perform the *Entry Procedure* now.

Sensor or Cal Factors Changed

If you are changing sensor modules or if the cal factors for your Sensor Module have changed (due to repair or calibration), perform the *Entry Procedure* to enter the new cal factors.

Not Certain if Correct Cal Factors Entered

If you are not certain that the cal factors in the HP 8902A match the cal factors of the Sensor Module you are using, perform the *Verification Procedure* provided in this section. If the cal factors in the instrument do not match those listed on the label of your Sensor Module, perform the *Entry Procedure*.

Microwave Sensor Module

If you are entering calibration data for a microwave Sensor Module, such as the HP 11792A, key in **27.1 SPCL** to enter the Frequency Offset Mode and then perform the *Entry Procedure*. (When you get to step 7, enter the calibration data directly from the Sensor Module's label.)

Entry Procedure

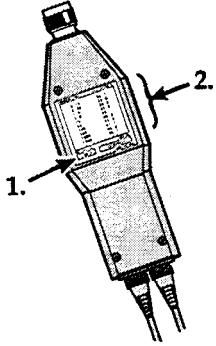

1. Find the Reference Calibration Factor on the label of your Sensor Module (REF CAL FAC). Record that value in the space provided in step 6 of this procedure.
2. Find the Calibration Factors listed on the Sensor Module label (CAL FACTOR %). Record each value in the appropriate space provided in step 7 of this procedure.
3. Connect the Sensor Module to your HP 8902A and press the Blue Shift key and then the green AUTOMATIC OPERATION key on the front panel of the HP 8902A.
4. Key in 37.9 SPCL (press the 37.9 digit keys and then the SPCL key, lower right corner). This clears the HP 8902A's non-volatile, cal factor storage table in case it contained any incorrect data.
5. Press the RF POWER key. The instrument will display Error 15. (Error 15 will go away once the calibration data is entered.)

Enter Reference Cal Factor

6. Key in 37.3 SPCL, _____, the Blue Shift key, and then the MHz key.

Remember



Press the CLEAR key if you miskey a digit. If you suspect that you have entered wrong data, complete the Entry Procedure and then perform the Verification Procedure to check the stored data. The Error Correction Procedures will enable you to change any incorrect data.

Enter Frequency/Cal Factor Pairs

7. Enter the frequencies and cal factors using the key sequence (Entry Code, Frequency, then Cal Factor%) shown in the table below. Repeat the procedure for each frequency/cal factor pair listed.

Entry Code	Frequency	Cal Factor %
37.3 SPCL	.1 MHz	_____ Blue key, MHz
37.3 SPCL	.3 MHz	_____ Blue key, MHz
•	1 •	_____ •
•	3 •	_____ •
•	10 •	_____ •
•	30 •	_____ •
•	100 •	_____ •
•	300 •	_____ •
•	1000 •	_____ •
•	2600 •	_____ •

8. Press the green AUTOMATIC OPERATION key to reset the instrument to normal operation. You have completed the cal factor Entry Procedure. The following Verification Procedure will enable you to verify that the data in the cal factor storage table is correct.

Verification Procedure

1. Press the green **AUTOMATIC OPERATION** key and then the **RF POWER** key. If the HP 8902A displays Error 15, there is no calibration data stored in the instrument; perform the *Entry Procedure*.
- Verify Reference Cal Factor**
2. Key in **37.5 SPCL**, the **Blue Shift** key, and then the **MHz** key. If the displayed Reference Cal Factor does not match the Reference Cal Factor (REF CAL FAC) on your sensor module, perform step 1 and step 6 in the *Entry Procedure*.
- Verify Frequency/Cal Factor Pairs**
3. Repeat the key sequence shown below to display each frequency and Cal Factor stored in the HP 8902A's non-volatile memory. Check each frequency and cal factor pair against those listed on your sensor module. (If you want to review the cal factor storage table more than once, enter 37.5 SPCL to return to the beginning of the table.)

Display Code	Display Frequency	Display Cal Factor %
37.6 SPCL	Blue key, ↑kHz	Blue key, MHz

4. Press the green **AUTOMATIC OPERATION** key to reset the instrument to normal operation. You have completed the verification procedures. You will not need to repeat the *Entry Procedure* again unless you use the HP 8902A with another Sensor Module or change the cal factors for this Sensor Module (due to repair or recalibration).

Error Correction Procedures

Cal Factor

- If the frequency is correct but the cal factor is not, perform step 7 in the *Entry Procedure* for that frequency and enter its correct cal factor only. (The HP 8902A will place the new entry in the correct position in the table and remove the incorrect cal factor.) (For example, if an incorrect cal factor value was entered for 10 MHz you would correct it by entering **37.3 SPCL, 10 MHz**, the correct cal factor value, **Blue Shift** key, **MHz**. The HP 8902A automatically positions the new cal factor in the 10 MHz position in the table.)

Frequency

- If an incorrect frequency is stored in the table, remove the incorrect frequency by performing step 7 of the entry procedure using the incorrect frequency and entering 0 as the cal factor.

Both

- If you need to add both a frequency and its cal factor to the storage table, perform the entry procedure (step 7) for the correct frequency and cal factor. (The HP 8902A will place the new entry in the correct position in the table.)

C

Index

A

AM, 1-9
 calibration, 3-2
Attenuator Measurement, 5-9
Audio, 3-1
 distortion, 1-16
 filters, 1-11
 frequency, 1-15
 level, 1-17
Auto Tuning, 1-6, 2-2
Automatic Operation, 1-8

C

Calibration,
 AM and FM, 3-2
 RF Power, 1-18, 4-2
 TRFL, 1-21, 4-3
Calibration Factors, B-1

D

Dashes, 1-4
 two, 1-4
 four, 1-4
 six, 1-21
Detectors,
 audio, 1-10
 TRFL, 4-3
Drift,
 RF Frequency Measurements, 2-7
 Modulation and Audio Measurements, 3-6
 TRFL Measurements, 4-9

E

Error Codes, 1-4
 RF Frequency and Frequency Error, 2-10
 Modulation and Audio, 3-8
 RF Power and TRFL, 4-13

F

FM, 1-11
 calibration, 3-2
 de-emphasis, 1-11
 residual characteristics, 5-6
Frequency Error, 1-7, 2-1
 resolution, 1-7
 parts-per-million, 5-4
Frequency Offset Mode, 5-4
(See also RF Frequency),

H

Harmonics, 2-3
Harmonic Mixing, 5-11
HP-IB, 2-9, 3-8, 4-12

I

IF Average Detector, 4-3
IF Filters, 2-5, 4-7
IF Synchronous Detector, 4-3
Image Signals, 2-6
Instrument Preset, 1-8

M

Manual Tuning, 1-6, 2-4
Modulation, 1-9, 3-1
 flatness, 5-8
MODULATION OUTPUT/AUDIO INPUT, 1-11, 1-16

N

Noise,
 RF Frequency Measurements, 2-6
 Modulation and Audio Measurements, 3-6
 TRFL Measurements, 4-8

O

Output Flatness, 5-3

P

Phase Modulation, 1-13
Power (See RF Power),

R

Range Hold, 5-2, 5-5
Ratio, 5-3, 5-7, 5-8
Recal, 1-24, 4-4
Relative TRFL Measurements, 4-5
Residual Modulation, 5-6
RF Frequency, 1-5, 2-1
 low-level, 5-2
 resolution, 1-5
RF Power, 1-19, 4-1
 calibration, 1-18, 4-2
 calibration factors, B-1
 tuning, 4-7
 versus TRFL, 4-12

S

Selectivity,
 RF Frequency Measurements, 2-5
 Modulation and Audio Measurements, 3-5
 TRFL Measurements, 4-7
Sensitivity, 2-7, 3-7, 4-13
 RF Frequency Measurements, 2-7
 Modulation and Audio Measurements, 3-7
 TRFL measurements, 4-13
Sensor Module, B-1
 changing, 4-10
 microwave, B-1
 without, 2-9, 3-8, 4-11
SET REF, 4-5
Signal-to-Noise, 5-7
SINAD, 5-7
Special Functions, 1-26
 special display, 1-26
Store, 4-8

T

Time Base, 2-9, 3-8, 4-12
Tone Burst FM, 5-5
Track Mode, 1-6, 2-4
Tuned RF Level, 1-21, 4-1
 accuracy, 4-5
 calibration, 1-21, 4-3
 detectors, 4-3
 measurement ranges, 4-4
 noisy source, 5-11
 spur measurements, 5-10
 tuning, 4-7
 versus RF Power, 4-12
Tuning Modes, 1-6
 auto tuning, 1-6, 2-2
 manual tuning, 1-6, 2-4
 selection, 1-7

U

Uncal, 1-24

Z

Zero key, 1-19

D

Other Publications

Precision Measuring Receiver,
(Data Sheet) November 1985
5953-8437 Spokane Division

HP 8902A Measuring Receiver,
(Flyer) March 1983
5953-8380

Accurate Characteristics at Millimeter-Wave Frequencies,
(Product Note) November 1985
5953-8436

HP 8902A Measuring Receiver Operation and Calibration Manual,
December 1985
08902-90029

HP 8902A Measuring Receiver Service Manual,
08902-90031

HP 8902S Microwave Measurement System Manual,
December 1985
08902-90046

***HP 8902A Microwave Signal Generator Calibration System
Option E04 Manual,***
08902-90048

HP 11722A Sensor Module Operating and Service Manual,
October 1983
11722-90009

HP 11792A Sensor Module Operating and Service Manual,
March 1983
11792-90008

For information about Hewlett-Packard products and services, telephone the local Hewlett-Packard sales and support office listed in your telephone directory. Or write to the appropriate address listed here.

United States

Hewlett-Packard Company
Microwave and
Communications Group
3000 Hanover Street
Palo Alto, CA 94304

Hewlett-Packard Company
4 Choke Cherry Road
Rockville, MD 20850

Hewlett-Packard Company
5201 Tollview Drive
Rolling Meadows, IL 60008

Hewlett-Packard Company
5161 Lankershim Blvd.
North Hollywood, CA 91601

Hewlett-Packard Company
2000 South Park Place
Atlanta, GA 30339

Canada

Hewlett-Packard (Canada) Ltd.
6877 Goreway Drive
Mississauga, Ontario
Canada, L4V1M8

Europe and Africa

Hewlett-Packard S.A.
P.O. Box 529
1180 AM Amstelveen
The Netherlands

Australasia

Hewlett-Packard Australia Ltd.
31-41 Joseph Street
Blackburn, Victoria 3130
Australia

Japan

Yokagawa-Hewlett-Packard Ltd.
29-21, Takido-Higashi, 3-Chome
Suginami-ku, Tokyo 168
Japan

Far East Area

Hewlett-Packard Asia Headquarters
47th F, China Resources Bldg.
26 Harbour Road, Wanchai
Hong Kong

Latin America

Hewlett-Packard Company
3495 Deer Creek Road
Palo Alto, CA 94304 U.S.A.

LOCAL OPERATION

This space is provided for you to store the *HP 8902A Basic Operation and Application Guide* (HP part number 5953-8458) that is included separately with this manual package.

This guide contains all basic information about the local and remote operation of the Measuring Receiver. If you have not yet operated the Measuring Receiver, you should use this document to become familiar with basic operation of the instrument. After you learn basic operation of the Measuring Receiver, you may want to put that supplement here for easy reference.

(Put this page behind the "Local" tab in the *Operation and Calibration Manual*.)

Remote Section Contents

REMOTE OPERATION VIA THE HEWLETT PACKARD INTERFACE BUS (HP-IB)	3-13
• Introduction to the Section	3-13
• How to Use this Section to Make a Measurement	3-13
PROGRAMMING THE MEASURING RECEIVER	3-13
• Overview	3-13
• Valid Programming Codes	3-13
• Invalid Characters	3-14
• Programming Syntax	3-15
• Code String Syntax (Sequence Dependency)	3-16
• Programming Examples	3-17
• Reference Tables	3-17
DATA OUTPUT	3-18
• Data Output Format	3-18
HP-IB INFORMATION	3-19
• HP-IB Capabilities	3-19
• HP-IB Address	3-20
MEASURING RECEIVER REMOTE CAPABILITIES (IEEE-488)	3-21
• Triggering Measurements	3-22
• Clear	3-25
• Remote/Local	3-26
• Local Lockout	3-26
• Clear Lockout/Set Local	3-27
• Service Request Message (SRQ)	3-27
• Status Byte	3-32
• Abort	3-33
• Pass Control/Take Control	3-33
• Status Bit	3-33
ADDITIONAL INFORMATION	3-33
• Annunciators	3-33
• Reading the HP-IB Address Switch and SRQ Status	3-34
• TALK and LISTEN Status Descriptions	3-35
• Code Execution in the Measuring Receiver	3-35

3-6. REMOTE OPERATION VIA THE HEWLETT PACKARD INTERFACE BUS (HP-IB)

Introduction to the Section

This section documents how the instrument interacts with a controller over HP-IB in remote operation. This section is intended as a reference document for operators who are familiar with their controller protocol and programming language, and is designed to be used after you have been introduced to basic front-panel and remote operation by the *HP 8902A Basic Operation and Application Guide* (HP part number 08902-90049) which is included with this documentation package.

Accurate measurements are dependent on the proper functioning of the both the HP-IB and the Measuring Receiver. The *Basic Functional Checks of the Measuring Receiver* and the *Basic Functional Checks of the Hewlett Packard Interface Bus (HP-IB)* verify that the Measuring Receiver and HP-IB are operating properly and can respond to or send bus messages.

How to Use this Section to Make a Measurement

Beginning Users: You will need to read the *HP 8902A Basic Operation and Application Guide* and perform the procedures described there to become familiar with the basic operation of the instrument. Then read the portions of the *Detailed Operating Instructions* (in this manual) describing the measurement you want to make. Then return to this section and read "Programming the Measuring Receiver", paragraph 3-7. This information should be enough to enable you to make most measurements.

Intermediate Users: If you are familiar enough with programming the instrument to feel you can skip the above steps, you may be interested in more specific information. In this case read the paragraphs titled, "Data Output", "Hewlett Packard Interface Bus", "Measuring Receiver Remote Capabilities", and/or "Additional Information" as appropriate to your needs.

Advanced Users: You may be able to program the instrument just using the tables in the back of this section which list the codes required to make measurements, the modifiers for each measurement, and other related information. Specific subjects such as Triggering, the Service Request Message and the Status Byte may be of interest. Explanations can be found in paragraphs of the same name.

3-7. PROGRAMMING THE MEASURING RECEIVER

Overview

All Measuring Receiver functions are fully programmable, except the POWER switch.

The Measuring Receiver can be externally triggered (Refer to "Triggering Measurements", under paragraph 3-10.) Triggering can be used to allow the Measuring Receiver to settle before making a measurement. It can be used to control when the Measuring Receiver takes a measurement and outputs the result.

Valid Programming Codes

The HP 8902A will execute:

- The function codes described in Table 3-11, "Measuring Receiver Function to Code Summary"
- Valid special functions (refer to page 3-275 for a list of special functions). All special function codes are formed by the special function number followed by the code "SP"
- The HP-IB commands described in Table 3-7, "Measuring Receiver Remote Capabilities Table".

As a convenience, all lower case alpha characters are treated as upper case. Commas and spaces between program codes are ignored by the instrument and therefore may be used to improve readability in programming.

Measurement Codes All front-panel keys except the LOCAL key have corresponding instrument-dependent program codes. These codes consist of either two alphabetic characters, or an alphabetic character and a number; e.g., M3. The underlined letters on the front-panel key labels are both letters or the initial letter of the programming code for that function. For example, the code for AUTOMATIC OPERATION is AU, and the codes for TRACK MODE are K1 and K0. The entire list of programming codes required to make measurements with the HP 8902A (not including special functions) are contained in Tables 3-11 and 3-12.

Turning Off Functions When operating in local operation, many of the functions toggle on and off with successive keystrokes. In remote operation, a specific code turns off the functions. The HP-IB Codes for turning off these functions are given in Table 3-1, "Turning Off Functions".

Table 3-1. Turning Off Functions

Functions Off	Code
Audio Input Off (Mod. Output On)	A0
Calibrate Off	C0
Disable Error Function Off	B0
Range Hold Off (Auto Range On)	G0
All HP Filters Off	H0
Track Mode Off (Lock Mode On)	K0
All LP Filters Off	L0
dB Ext. Attenuator Off	N0
Pre-display and De-emphasis Off	P0
Ratio Off	R0

Invalid Characters

The following Table 3-2, "Response to Unused ASCII Characters" lists the Measuring Receiver's response to various ASCII characters not used in its code set. The characters in the left-hand column are ignored unless they appear between two characters of a program code (e.g. M 3, space between the characters of a function code); in which case, they generate Error 24. The characters in the right-hand columns, if received by the Measuring Receiver, will always cause Error 24 (invalid HP-IB code) and a Service Request message to be generated.

Table 3-2. Response to Unused ASCII Characters

Ignored *	Generates Error 24
!	@
"	J
'	Q
·	}
#	Y
%	DEL
&	~
([
)]
*	{
blank space)
/	
, (comma)	\
	_

*Except when inserted between two characters of a program code.

Programming Syntax

Function Code Syntax The function code syntax is typically equivalent to the front-panel keystroke sequence used in local operation. (Refer to *Basic Operation and Application Guide* or the *Detailed Operating Instructions* for keystroke sequences.)

There are three different syntax which execute functions. Refer to Table 3-3, "Function Code Syntax Examples" for examples.

- 1) Using a two character code or suffix alone, which is the common case.
- 2) Using a number and a suffix.
- 3) Using a prefix (usually a special function), a number and a suffix.

Table 3-3. Function Code Syntax Examples

Code	Operation Performed
MZ	Center I.F. Frequency
100 MZ	Tune to 100 MHz
27.3SP 100 MZ	Enter and enable external L.O. frequency of 100 MHz
CF	Read current Calibration Factor
98 CF	Enter a Calibration Factor of 98%
37.3SP 98 CF	Enter an automatic RF Power calibration factor of 98%

Numeric Data Syntax When entering input frequency, entering ratio or limit references, or entering any numeric data (other than two-character function codes) into the Measuring Receiver, certain requirements must be met:

- Numeric data may consist of a signed mantissa of up to eight digits, with one decimal point, and a one- or two-digit, signed exponent.
- The decimal point may fall between any two digits of the mantissa. If a decimal point is entered before the first digit, a leading zero will be inserted by the Measuring Receiver.
- Any digit beyond the eight allowed for the mantissa will be received as zero.

The following table shows examples of the differences between data entered into the Measuring Receiver and the data accepted.

Table 3-4. Data Input Examples

Number Entered in Code	Number Accepted by Instrument
.1234567899999	0.1234567
1234567890	12345678 E02

Code String Syntax (Sequence Dependency)

For accurate measurement results, functions should be programmed in the following order to insure proper sequencing of events and switching in the instrument as appropriate to the measurement. The letter X in the following example represents a number.

Function codes that have the same alpha-character should be entered in numeric order to ensure proper execution; e.g., P1 should come before P4.

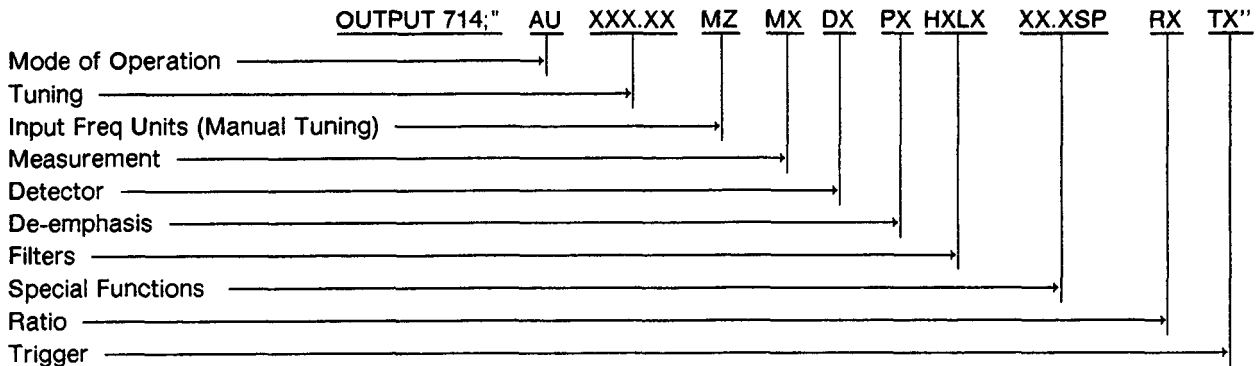

The following information should be considered in addition to the information above when writing programming strings.

- AU (Automatic Operation). When Automatic Operation is used, it should appear at the beginning of a program string. Automatic Operation sets all special functions prefixed 1 through 10 to their zero-suffix mode. Most other special functions are also set to zero-suffix.
- P0 (Pre-Display Off and De-Emphasis Off). When pre-display is turned off using P0, all FM de-emphasis is turned off.

NOTE

Pre-Display is not turned off if the Audio RMS Detector (D8) is on when P0 is selected. In this case, FM De-emphasis will be turned off, but Pre-display will be left on. Pre-display is required by the Audio RMS hardware.

- T2 and T3 (Trigger Immediate and Trigger With Settling). Trigger codes should always appear at the end of a program string, and the triggered measurement results must be read before any additional program codes are sent to ensure an accurate measurement. When either of the trigger codes T2 or T3 is received by the Measuring Receiver, a measurement cycle is immediately initiated.

Programming Examples

Code String Example Function codes may be sent to the instrument in a continuous string as shown below. The code string shown will program the instrument to determine the positive peak de-emphasized (75 μ s) FM deviation of an input signal at 104.5 MHz. The measurement is triggered with T3, Trigger with Settling.

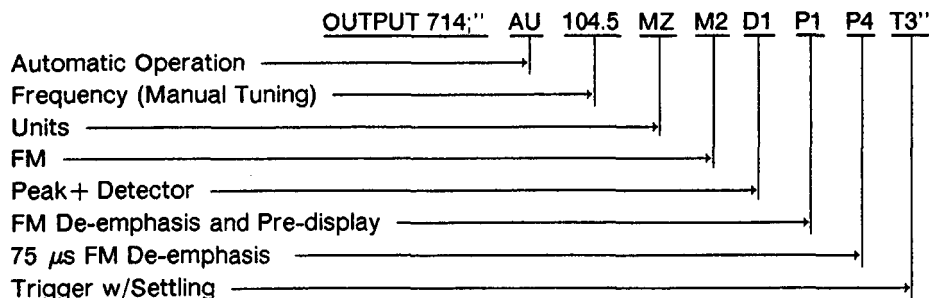

Example Measurement Program The following example provides you with a sample of how the previous information might be used to program the HP 8902A to make a particular measurement. This example demonstrates measuring AM in the 50 Hz to 15 KHz bandwidth of a 100 MHz carrier using Trigger Hold and Trigger with Settling.

10 OUTPUT 714; "IP"	Instrument Preset to configure instrument to a known state.
20 OUTPUT 714; "M1 100 MZ H1 L2 T1"	Send code to configure instrument for measurement.
30 OUTPUT 714; "T3"	Trigger settled measurement.
40 ENTER 714;A	Read data into variable A.
50 PRINT A	Print variable A
60 END	

Reference Tables

Table 3-11, "Measuring Receiver Function to Code Summary" This table lists the instrument-specific function code for each Measuring Receiver function described in the *Detailed Operating Instructions* of this manual.

Table 3-12, "Code to Measuring Receiver Function Summary" This table has the same information as Table 3-11, "Measuring Receiver Function to Code" but is organized alpha-numerically by code.

NOTE

The following tables are intended as a reference for advanced users who are familiar with the HP 8902A measurement capabilities.

Table 3-13, "Measurement Modes and Codes" All of the functions listed on this table are defined as "measurement modes" in the instrument. The instrument can only be in one Measurement Mode at a time. If a measurement mode is volatile, pushing the CLEAR key or entering CL over the bus, will return the instrument to the last selected, non-volatile measurement mode.

This table lists all the measurement modes of the HP 8902A Measuring Receiver and their programming codes. This table also lists whether or not the measurement mode is volatile, whether the receiver section of the HP 8902A is used to make the measurement, and whether the Demodulation Output is blanked during the measurement.

Table 3-14, "Measurement Modifiers" Whenever a measurement is selected, the Measuring Receiver sets up its internal circuitry so it can make the most accurate measurement possible. These settings can be altered by the operator to modify the measurement.

This table lists the measurement modifiers for the primary measurement modes listed in Table 3-13, "Measurement Modes and Codes".

To see what modifiers are being automatically selected,

- use the Special Special display to read the Range in use,
- read the front-panel lights for the Detectors, Filters and De-Emphasis in use and
- see Table 3-15 or -16, "Enabling/Disabling Variable Parameters (Front Panel or Remote)" for a summary of how to read the Calibration Factors, the Frequency Offset, the dB external Attenuation, the Limits set, and whether Ratio has been selected.

Table 3-15, "Enabling/Disabling Variable Parameters (Front Panel)" This table lists ways of verifying from the front panel the values of the Calibration Factors, Frequency Offset, dB External Attenuator, Limit/Ratio and Set Reference functions.

Table 3-16, "Enabling/Disabling Variable Parameters (Remote)" This table is the same as Table 3-15 except that it shows the programming codes required instead of the front-panel keystrokes.

Table 3-17, "HP 8901A/02A Code Differences" This table lists the function code differences for identical functions of the HP 8902A and the HP 8901A, and should be useful in modifying existing HP 8901A control programs to drive an HP 8902A.

3-8. DATA OUTPUT**Data Output Format**

Numeric Data As shown below, the output data is always in the form of an implicit-point exponential constant. Data is always output in fundamental units (for example, Hz, watts, radians, dB, %, etc.), and the decimal point (not sent) is assumed to be to the right of the tenth digit of the mantissa.

Data values never exceed +9 000 000 000E+01. Output values greater than this are Error Messages.

Output data is displayed using the following format: first the sign, then 10 digits (leading zeros not suppressed) followed by the letter E and a signed two-digit exponent. The last two characters of the string are a carriage return (CR) and a line feed (LF) in string positions 16 and 17. Refer to Table 3-5, "Data Output Examples" for examples.

Table 3-5. Data Output Examples

Instrument Display	Data Output
969.21346 MHz	+0096921346E+01<CR><LF>
34.92 kHz	+0000003492E+01<CR><LF>

Error Messages Error message format and syntax are described in the *Error Messages Summary* section on page 3-286.

3-9. HP-IB INFORMATION

HP-IB Capabilities

The interface functions that the HP 8902A implements are defined in Table 3-6, "IEEE Std 488 Interface Function Capabilities". The Measuring Receiver's HP-IB command capabilities are compatible with the IEEE Standard 488, and the identical ANSI Standard MC1.1.

For more information about the Hewlett-Packard Interface Bus (HP-IB), refer to:

- IEEE Standard 488,
- ANSI Standard MC1.1,
- the Hewlett-Packard Electronic Systems and Instruments catalog,
- the booklets, "Improving Measurements in Engineering and Manufacturing" (HP part number 5952-0058), and "Tutorial Description of HP-IB" (HP part number 5952-0156).

Table 3-6. IEEE Std 488 Interface Function Capabilities Table

Bus Command	Capability
Source Handshake	SH1 Complete Capability
Acceptor Handshake	AH1 Complete Capability
Talker Function	T5 Complete Capability including Talk Only *
Extended Talker	TE0 No Capability
Listener Function	L3 Complete Capability including Listen Only mode
Extended Listener	LE0 No Capability
Service Request	SR1 Complete Capability
Remote Local	RL1 Complete Capability
Parallel Poll	PP0 No Capability
Device Clear	DC1 Complete Capability
Device Trigger	DT1 Complete Capability
Controller	C0 No Capability
Driver Electronics	E1 Open Collector Drivers
* Instrument also has a Talk Status Only mode	

HP-IB Address

Factory Set Address

The Measuring Receiver's HP-IB address is set to decimal 14 at the factory with Talk Only and Listen Only modes disabled. The address can be changed by following the instructions in paragraph 2-3 under "HP-IB Address Selection".

Reading the Address

To display the HP-IB address in decimal on the front panel, select BUS ADRS by pressing the Blue key and then the LOCAL key. The displayed address is in the form:

Addr=NN

Where NN is the two-digit address in decimal. The display will time out after a few seconds.

Refer to "Additional Information", paragraph 3-11 for more information about HP-IB address.

3-10. MEASURING RECEIVER REMOTE CAPABILITIES (IEEE-488)

The capabilities of the HP 8902A in remote operation and their related IEEE Std 488 terms are described in Table 3-7, "Measuring Receiver Remote Capabilities Table". The twelve capabilities described there are further described in the paragraphs following the table.

Table 3-7. Measuring Receiver Remote Capabilities (1 of 2)

Measuring Receiver Capabilities			IEEE Std 488 *	
Capability	Enabled	Response	Commands and Control Lines	Interface Functions
Data	Yes	All front-panel functions, special functions, and remote-only functions are programmable, except the POWER switch. The Measuring Receiver can send the Status Byte, and message and setting information. All measurement results, special displays, and error outputs (except dashed displays) are available via the bus.	MLA MTA	AH1 SH1 T5 L3
Trigger	Yes	If in remote and addressed to listen, the Measuring Receiver makes a settled measurement. It responds equally to bus command GET and program code T3, Trigger with Settling.	GET	DT1
Clear	Yes	Clears Status Byte, RQS bit, Service Request message (if issued), and sets the SRQ Mask to the 22.0SP state. Responds equally to DCL and SDC bus commands. Resets many additional parameters as shown in Table 3-8, "Response to a Clear Message."	DCL SDC	DC1
Remote	Yes	The Measuring Receiver's remote mode is enabled when the REN bus line is true. However, it remains in local (i.e., the front panel is active) until it is first addressed to listen. The output signal and internal settings are unchanged when the Measuring Receiver enters remote mode. All front-panel keys are disabled except LOCAL and CLEAR, unless the instrument is in Local Lockout.	REN MLA	RL1
Local	Yes	The Measuring Receiver returns to front-panel control when it receives the Local message. No instrument settings or functions are changed except Trigger is set to Free-Run (T0). Responds either to the GTL command or the keyboard Local key. The LOCAL key will not work if the instrument is in LOCAL LOCKOUT.	GTL	RL1
Local Lockout	Yes	All front-panel keys including the LOCAL and CLEAR keys are disabled during Local Lockout so that only the controller or the POWER switch can return the instrument to Local.	LLO	RL1
Clear Lockout/ Set Local	Yes	The Measuring Receiver returns to Local and Local Lockout is no longer true when the REN bus lines go false.	$\overline{\text{REN}}$	RL1

* Commands, Control Lines, and Interface Functions are defined in IEEE Std 488 (and the identical ANSI Standard MC1.1). Knowledge of these might not be necessary if your controller describes its capabilities in terms of the HP-IB capabilities shown in the left column.

Table 3-7. Measuring Receiver Remote Capabilities (2 of 2)

Measuring Receiver Capabilities			IEEE Std 488*	
Capability	Enabled	Response	Commands and Control Lines	Interface Functions
Pass Control/ Take Control	No	The Measuring Receiver cannot pass or take control of HP-IB.		C0
Service Request	Yes	The Measuring Receiver sets the SRQ bus line true if any of the conditions defined in the Status Byte occurs and has been enabled by the SRQ Mask (Special Function 22) to send the Service Request message.	SRQ	SR1
Status Byte	Yes	The Measuring Receiver responds to a Serial Poll Enable (SPE) bus command by sending an 8-bit byte when addressed to talk. Bit 6 is true if the instrument has sent the Service Request Message.	SPE SPD MTA	T6
Status Bit	No	The Measuring Receiver does not respond to a parallel poll.		PP0
Abort	Yes	The Measuring Receiver stops talking or listening.	IFC	T6 L3

* Commands, Control Lines, and Interface Functions are defined in IEEE Std 488 (and the identical ANSI Standard MC1.1). Knowledge of these might not be necessary if your controller describes its capabilities in terms of the HP-IB capabilities shown in the left column.

Triggering Measurements

In remote operation, two triggering modes are available: Free-run and Trigger Hold. In Free-run mode, measurements are continually, automatically taken. In Trigger Hold mode, the instrument sets up for the measurement and then waits for a trigger to be received. Valid triggers to use in Trigger Hold are: T2, T3, GET or the CLEAR key.

The instrument goes into Trigger Hold mode after it receives a trigger (except the CLEAR key) even if it was in Free-run before it received the trigger.

TRIGGER MODES (T0 and T1)

Free Run Mode (T0) This trigger mode is in effect in local operation, and is also in effect in remote when Trigger Hold mode has not been selected. Measurements are made and measurement data updated as rapidly as settings can be changed without regard for settling of ANY internal or external circuitry or setting changes.

NOTE

- The Measuring Receiver is always in Free-run trigger mode (T0) after receiving a Device Clear (DCL) message, entering remote from local, or receiving Instrument Preset (IP).
- Measurements might NOT be completed if Free-run (T0) is used if there is HP-IB activity between other HP-IB devices (e.g. a controller talking to another instrument) during the measurement. Trigger Immediate (T2) or Trigger with Settling (T3) should be used under these conditions.

Trigger Hold Mode (T1) In Trigger Hold mode, internal settings can be changed by the instrument itself or by the user via the bus; however, the instrument is inhibited from outputting any data to the front-panel key lights and display, or to the HP-IB until it receives a trigger. The following data can be sent before the trigger is received:

- A Service Request message if an enabled LIMIT is reached, or if an HP-IB code error occurs.
- The Status Byte if the instrument is serial polled. (A serial poll, however, will trigger a new measurement, update displays and return the instrument to Trigger Hold.)

Measurement data is replaced with data acquired from subsequent triggered measurement cycles.

NOTE

When a trigger is received, the Measuring Receiver will not allow its measurement cycle to be interrupted. (Indeed, handshake of bus commands is inhibited until the measurement cycle is complete.)

Entering Trigger Hold The instrument is placed in this mode after it receives the programming code T1 or after a triggered measurement has been executed. This mode can then be used to set up the instrument for new measurements which are executed by a trigger.

Triggering Measurements from Trigger Hold When a measurement is triggered from Trigger Hold mode, the instrument makes the measurement. The display is updated as the new measurement cycle begins. The Status Byte will be updated (and the Service Request message issued if required) by the events that occur during the new measurement cycle.

Any of the following events will trigger a new measurement cycle when the instrument is in Trigger Hold:

- a. instrument receives a trigger,
- b. instrument receives its listen address,
- c. instrument receives GTL (Go To Local),

After the measurement is made, the instrument waits for the measurement results to be read. While waiting, the instrument can process most bus commands without losing the measurement results. Once the data (measurement results) are read onto the bus, the Measuring Receiver returns to the Trigger Hold mode.

Leaving Trigger Hold The instrument leaves Trigger Hold mode when it receives a trigger until the measurement is complete. The Measuring Receiver also leaves Trigger Hold when it receives:

- a. the Free Run code (T0), or
- b. when it is returned to local operation,
- c. a Device Clear Message (DCL or SDC), or
- d. Instrument Preset (IP).

TRIGGERS (T2, T3, GET, and the CLEAR Key)

All triggers are available in both Free Run and Trigger Hold modes, but after a trigger is received (except the CLEAR key), the instrument enters Trigger Hold mode.

Trigger Immediate (T2) When the Measuring Receiver receives the Trigger Immediate code, it makes one measurement and displays the result without a settling time delay.

Measurement results obtained via Trigger Immediate are normally valid only when the instrument is in a steady, settled state. The first result received from the instrument (using T2) may not be accurate.

Trigger With Settling (T3)**NOTE**

- *The use of Trigger With Settling does not remove the need to observe the normal warm-up precautions when using either the RF Power, AM, or FM Calibrator. Refer to the procedures "RF Power Calibration", "AM Calibration", or "FM Calibration" in the Detailed Operating Instructions*
- *If the settling time provided with T3 is not adequate to produce accurate measurements, use T0 (Free-run) and write a sub-program which compares measurement values until they are within a specified tolerance. (Delays, not included in the T3 settling time, in the source and/or the thermocouple in the Power Sensor can prevent accurate measurements.)*

Trigger With Settling is identical to Trigger Immediate except the Measuring Receiver inserts a settling-time delay before taking the requested measurement.

Group Execute Trigger (GET) Message When in remote and addressed to listen, the Measuring Receiver responds to a Trigger message (GET) by executing a settled-measurement cycle. The Measuring Receiver responds exactly as if it had received the program code T3 (Trigger With Settling).

Triggering Measurements With the CLEAR Key (CL) When the Measuring Receiver is in Trigger Hold mode (T1) and not in Local Lockout, the front-panel CLEAR key may be used to issue a Trigger With Settling. Each time the CLEAR key is pressed, the Measuring Receiver performs a settled-measurement cycle. The CLEAR key will not cause the instrument to enter Trigger Hold mode.

In Free Run mode the CLEAR key will clear the display, but not affect the timing of measurements and will not cause the instrument to enter Trigger Hold.

NOTE

The CLEAR key (CL) does not perform any of the functions of the Clear message (DCL or SDC).

Clear

The Measuring Receiver responds to the Clear message (DCL and SDC) the same way it responds to Instrument Preset (IP). The Clear message clears any pending Service Request message and clears the SRQ Mask (22.0SP). The settings the instrument will assume after receiving the Clear message are listed below in Table 3-8. Refer to "Instrument Preset" in *Detailed Operating Instructions* on page 3-239 for more information on the Instrument Preset default conditions.

The Clear message also clears any incomplete message or entries. For example, "M5100" (RF Frequency Measurement, 100, no terminator) would be cleared because no units terminator has been entered.

Table 3-8. Response to a Clear Message

Parameter	Setting
High-Pass Filters	All Off
Low-Pass Filters	All Off
FM De-emphasis	Off
Pre-display	Off
Calibration	Off
Measurement	Frequency
Detectors	Peak +
Ratio	Off
Limit	Not Enabled
Lower Limit Reference	150 kHz
Upper Limit Reference	1300 MHz
Limit Measurement Mode	Frequency
Automatic Operation	On
Manual Operation	
MHz Input Frequency	Automatic Tuning ¹
↑ and ↓ Step Size	0 kHz
SPCL	Special Functions prefixed 1 through 10 in zero-suffix mode; all others off
Modulation Output	FM (least sensitive range)
Service Request Mask	HP-IB code error enabled only (22.2SP)
Status Byte	Cleared
Trigger Mode	Free-run (T0)

¹ If MHz (code MZ) is selected immediately after the Clear message is received or after power-up, the Measuring Receiver will tune to 100 MHz.

Remote/Local

Mode Descriptions

Remote Mode In remote, the Measuring Receiver's front-panel controls are disabled except for the LOCAL and CLEAR keys. The LOCAL and CLEAR keys are only disabled by Local Lockout. However, front-panel displays and the output signal at MODULATION OUTPUT/AUDIO INPUT remain active and valid. Two triggering modes are available in remote operation: Free Run and Trigger Hold.

Displays which time out in Local do not time out in Remote. In Remote operation, the CLEAR key will clear the display and works as a trigger when Trigger Hold is used.

Local Mode In local, the Measuring Receiver's front-panel controls are fully operational. When the Measuring Receiver goes to local operation, the front-panel REMOTE annunciator turns off. However, when the Measuring Receiver is being addressed (whether in remote or local), its front-panel LISTEN or TALK annunciator lights. Free Run is the only triggering mode available in local operation.

Mode Transitions

Local to Remote Transitions The Measuring Receiver switches to remote operation upon receipt of the Remote message. No instrument settings are changed by the transition from local to remote. The Trigger mode will always be Free Run (T0) on entry to remote operation.

Remote to Local Transitions The Measuring Receiver always switches to local from remote whenever it receives the Local or the Clear Lockout/Set Local message. No instrument settings are changed by the transition from remote to local, except the Trigger mode will always be reset to Free Run.

If it is not in Local Lockout mode, the Measuring Receiver switches to local from remote whenever its front-panel LOCAL key is pressed.

NOTE

Remote to Local transitions will not clear a Service Request message.

Local Lockout

Local lockout disables the LOCAL key (and the CLEAR key) and allows return-to-local only under program control.

When a data transmission is interrupted, which can happen if the LOCAL key is pressed, the data being transmitted may be lost. This would leave the Measuring Receiver in an unknown state. To prevent this, a local lockout is recommended.

Clear Lockout/Set Local

The Measuring Receiver returns to local operation when it receives the Clear Lockout/Set Local message.

NOTE

Clear Lockout/Set Local can be accomplished by switching the power to STBY and back to ON. Returning to Local operation in this way has the following disadvantages:

- *It defeats the purpose of Local Lockout (that is, the system controller will lose control of the Measuring Receiver).*
- *Instrument configuration is reset to Power-up conditions listed in the Detailed Operating Instructions under "Instrument Preset" on page 3-239.*

Service Request Message (SRQ)

The Service Request Message (SRQ message) is being issued when the SRQ bus line is asserted and the SRQ light on the front panel is lit by the instrument. The Service Request message may be issued under following conditions:

- the instrument requires re-calibration or is uncalibrated,
- there has been a Frequency Offset mode change,
- an enabled limit has been exceeded,
- an instrument error has occurred,
- an HP-IB code error has occurred,
- measurement data is ready to be read.

The Measuring Receiver uses its Status Byte and the SRQ Mask (Special Function 22) to determine whether or not to issue a SRQ message. Refer to Figure 3-4, "Issuing a Service Request Message" throughout the following discussion of the Service Request Message, SRQ Mask and the Status Byte.

The Service Request Message is asserted when the RQS bit of the Status Byte is set by the instrument. The RQS bit is set automatically when one or more of the other bits in the Status Byte are set. For the bits other than the RQS bit of the Status Byte to be set, those bits must be enabled by the SRQ Mask before the instrument condition which will set them occurs.

The instrument can send the Service Request message in either local or remote operation.

Clearing the Service Request Message After the Service Request message has been sent, it will be cleared when the Status Byte is cleared which is described below under "Status Byte".

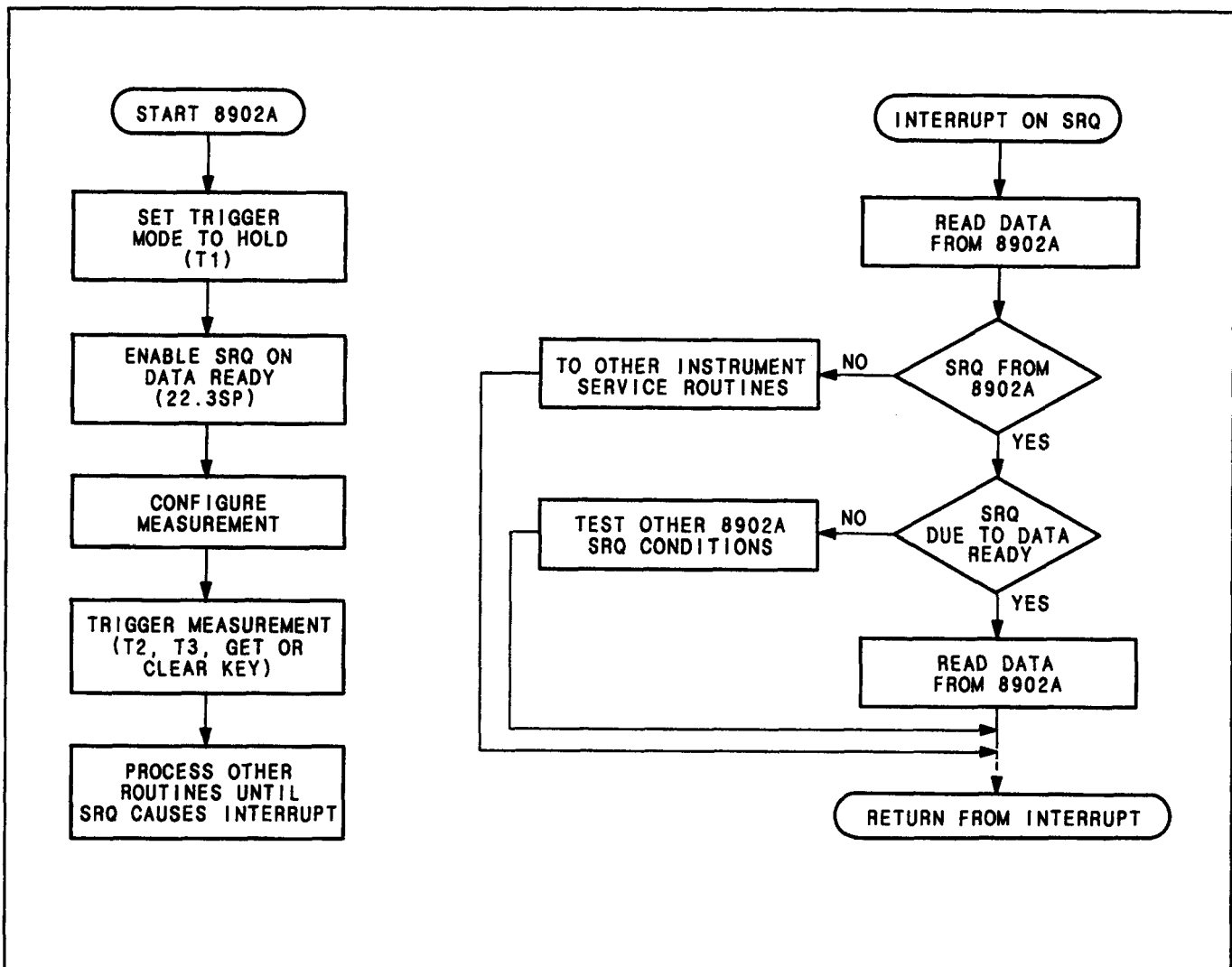

Figure 3-3. Example Flowchart Using the Service Request Message.

Using the Service Request Message The Service Request message can be used for detecting instrument conditions and instrument or HP-IB code errors.

The Service Request Message can also be used for signaling measurement data ready. Remote measurements are usually performed simply by triggering measurements, then reading the output data. In certain applications, the controller must control other instruments while the HP 8902A is making a measurement. Using the instrument's ability to issue the Service Request message when data is ready, frees the controller to process other routines until the Measuring Receiver is ready with data.

See Figure 3-3, "Example Flowchart Using the Service Request Message" for an example of using the SRQ message to signal the controller that the HP 8902A has completed its measurement and the data is ready.

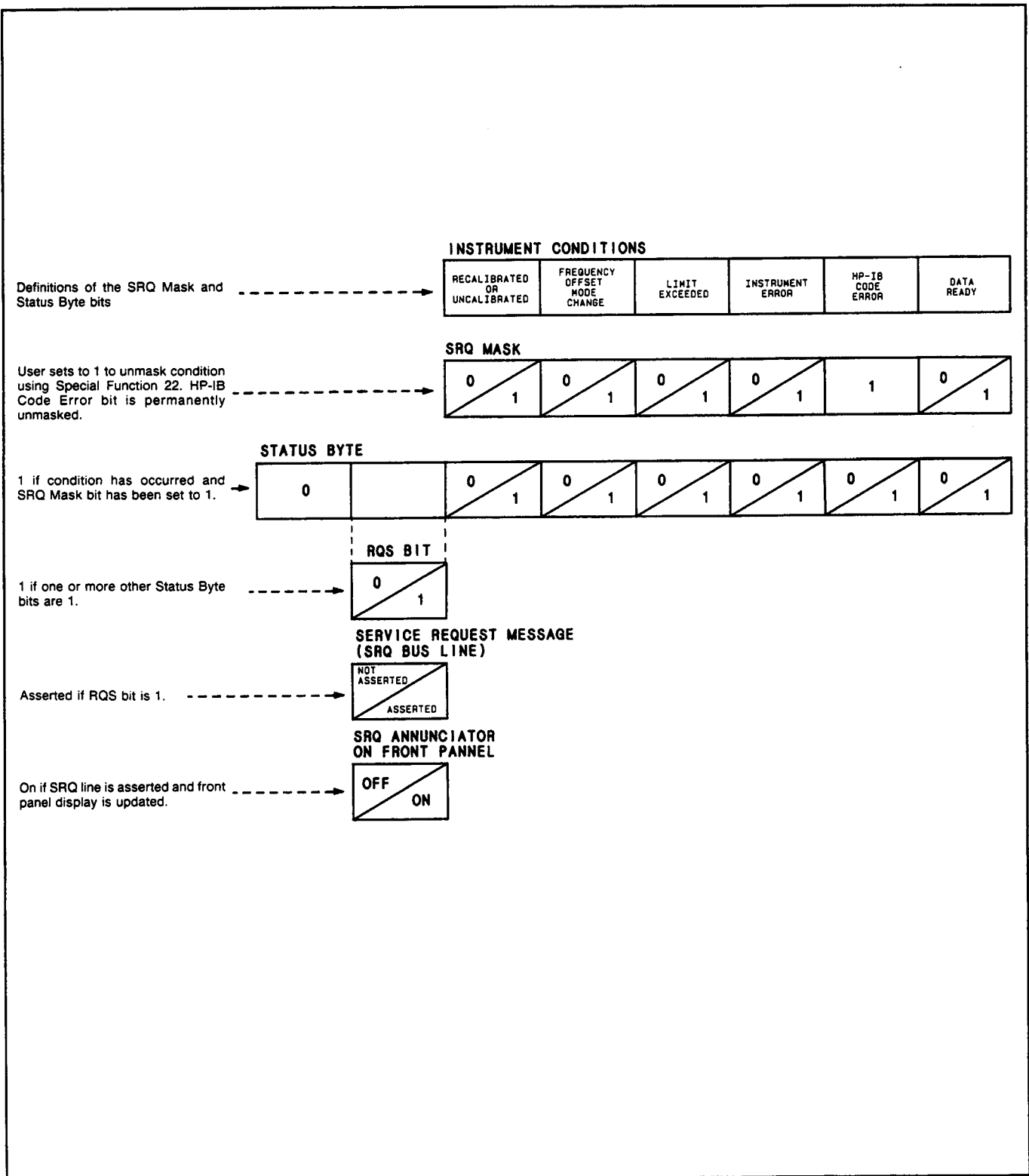

Figure 3-4. Issuing a Service Request

SRQ MASK (Special Function 22)

Overview Special Function 22 is used to set the bits of the SRQ Mask. The set SRQ Mask bits unmask the bits of the Status Byte. At power-up or Instrument Preset, all Status Byte bits are masked except the HP-IB Error Code bit. The appropriate SRQ Mask bits must be set to 1 by the operator to unmask any other Status Byte bit. Refer to Figure 3-4, "Issuing a Service Request" for a graphic example of these relationships.

NOTE

Bit 1 of the SRQ Mask is permanently set to 1; therefore, an HP-IB code error will ALWAYS generate a Service Request message. This means that the Service Request message CANNOT be disabled.

Setting the SRQ Mask Only bits 0, 2, 3, 4 and 5 can be set. Bit 1 (weight=2) is permanently set.

To set the SRQ Mask bits and unmask the Status Byte bits which you want to cause the Service Request Message to be issued:

- Sum the weights of the desired conditions using Table 3-9 below. Use this sum as the suffix of Special Function 22.

NOTE

Since Bit 1 (HP-IB Code Error) is permanently enabled, if the weight is not summed in, it will be assumed by the instrument, for example 22.0SP is equivalent to 22.2SP.

- Enter the special function code (and suffix) via the front panel, then select SPCL; or, for remote operation, enter 22.<suffix>SP.

Example To set the SRQ Mask so that the Measuring Receiver will issue a Service Request message for all conditions except Data Ready, first compute the Special Function suffix by summing the corresponding weights.

$$4 + 8 + 16 + 32 = 60$$

Key in 22.60SP. (22.62SP would also work because of the permanently set HP-IB Error Code bit.)

Table 3-9. SRQ Mask and Status Byte Bit Descriptions

Bit Number	Mask Weight	Condition	Description
0	1	Data Ready	Asserted if unmasked when valid data is ready after a measurement. This can be used for any function which outputs to the bus.
1	2	HP-IB Code Error (Permanently Set)	Asserted when an invalid code is sent to the bus, or an error is made in programming the instrument. (Always unmasked.)
2	4	Instrument Error	Asserted if unmasked when an error is displayed on the instrument. Note that invalid bus codes are also instrument errors
3	8	Limit Exceeded	Asserted if unmasked when limits are enabled (14.XSP) and exceeded
4	16	Frequency Offset Mode Change	Asserted if unmasked when in Frequency Offset Mode and Manual Tune frequency is changed, or when entering or exiting the mode through 27.0/1/3 SPCL.
5	32	Recalibrate or Uncalibrated	Asserted if unmasked when the RECAL or UNCAL annunciators turn on.
6		RQS (Request Service)	This bit will always be set if any of the other bits are set.
7		Unused	Always 0.

Reading the SRQ Mask Read the SRQ Mask by entering 22.64SP. This initiates a "measurement" of the mask value which is displayed and available over the bus. This value will be displayed in decimal and can be interpreted using Table 3-9 "SRQ Mask and Status Byte Bit Descriptions".

Clearing the SRQ Mask Clear the SRQ Mask by any of the following operations:

- entering 22.0SP (Remember this will not clear the HP-IB Code Error bit.)
- Sending the Device Clear (DCL) message, sending Instrument Preset (IP) or powering up the instrument .

Status Byte

Overview

The Status Byte bits 0-5 reflect the status of the unmasked Instrument Conditions. Refer to Table 3-9, "SRQ Mask and Status Byte Bit Descriptions" for bit definitions. At power-up and Instrument Preset, the only Status Byte bit which is unmasked is the HP-IB Error Code bit.

The RQS bit (bit 6) is automatically set if any other bit in the Status Byte is set true. When the RQS bit is set, the Service Request message is sent. The front-panel SRQ annunciator turns on at the next front-panel display update. Once any Status Byte bit has been set, it remains set until the Status Byte is read.

If one of these Instrument Conditions occurs, while it is masked by the SRQ Mask, NEITHER the Status Byte bit corresponding to the condition NOR the RQS bit will be set, and the Service Request message will not be sent.

Reading the Status Byte

NOTE

- *A Status Byte Bit that is not unmasked by the SRQ Mask will ALWAYS read as a zero when the Status Byte is read. Only an unmasked bit can be read as a one, and then only if its initiating Instrument Condition occurs AFTER it is unmasked.*
- *Reading the Status Byte is the only accurate way to determine the condition of the SRQ bus line (Service Request message). The SRQ annunciator is only updated as the front panel is updated. It is NOT tied directly to the SRQ bus line.*
- *The Measuring Receiver cannot alter the Status Byte while in serial poll mode; therefore, it is not possible to continually poll the Status Byte while waiting for a condition to cause a bit to be set.*
- *Reading Status of non-existent devices (HP-IB addresses not in use) will hang the HP 8902A HP-IB and requires a Device Clear (DCL) message to clear the bus.*

The Status Byte can be read using a serial poll, only if the instrument sends a Service Request Message. Only those bits which are unmasked by the SRQ Mask can be read accurately.

Talk Status Only causes the instrument to only output the Status Byte. Refer to "TALK and LISTEN Status Descriptions" for more information.

Clearing the Status Byte

NOTE

Remote-to-Local transitions will not clear the Status Byte.

Once bits in the Status Byte are set, they can be cleared by the following operations.

- Reading the Status Byte by serial polling AFTER the condition is cleared. If the condition which set the bits persists, those bits and the RQS bit will again be set.
- Sending the Device Clear (DCL) message, presetting or powering up the instrument.
- In Talk Status Only, the Status Byte is cleared each time the one-byte Data message is issued to the bus
- Sending the Serial Poll Disable (SPD) bus command, or
- Sending the Abort message.

Abort

Abort abruptly terminates all listener/talker activity on the interface bus and prepares all instruments to receive a new command from the controller. Typically this is an initialization command used to place the bus in a known starting condition. The Measuring Receiver stops listening or talking when it receives the Abort message.

Pass Control/Take Control

The Measuring Receiver does not respond to the Pass Control/Take Control message because it cannot act as a controller.

Status Bit

The Measuring Receiver does not implement parallel poll operations and therefore cannot send the Status Bit message. The Status Bit should not be confused with the Status Byte which was discussed previously under "Status Byte".

3-11. ADDITIONAL INFORMATION

Annunciators

REMOTE Light: Lights when the instrument is operating in remote mode. When the Measuring Receiver goes to local operation, the front-panel REMOTE annunciator turns off.

LISTEN Light: Lights when the instrument is addressed to Listen.

TALK Light: Lights when the instrument is addressed to Talk.

SRQ Light: Lights when the Service Request message has been sent (SRQ line true), and the front panel has been updated.

Reading the HP-IB Address Switch and SRQ Status

The HP-IB switch sets the instrument address and the Talk and Listen modes of the instrument. To display the state of the HP-IB address switch and the SRQ Line in binary, enter 21.0SP.

This display does not time out. To clear the instrument display, press the CLEAR key.

The format of the display is as follows;

AAAAA.TLS

where AAAAA is a five-bit binary address with leading zeros blanked and TLS represent the status of the TON switch, LON switch and SRQ bus line respectively.

NOTE

- If T and L are both 1, the instrument is set to Talk Only (Talk Only overrides Listen Only).
- If all A bits are 1 and T is 1, the instrument will Talk Status Only (that is, output the status byte only).

A list of possible conditions of the TLS digits of the display is provided in the following table:

Table 3-10. TLS Table

Operating Mode	T Digit	L Digit	S Digit
Talk and Listen	0	0	1 or 0
Talk Only	1	1 or 0	1 or 0
Talk Status Only	1*	1 or 0	1 or 0
Listen Only	0	1	1 or 0

* Instrument address must be 11111 in binary. (31 in Decimal.)

Example If 1110.001 is the address displayed, then the HP-IB address is 1110 in binary (that is, 14 in decimal). The T digit is "0", and the L digit is "0" indicating that the instrument is set to be able to Talk and Listen. The S digit is 1 indicating that the instrument is issuing a Service Request Message.

For the same example, if the BUS ADRS key is used, Addr = 14 will be displayed. (No information about Talk Only, Listen Only, or SRQ is displayed.)

Setting the HP-IB Address The Measuring Receiver's talk and listen addresses are switch selectable as described in paragraph 2-7. Refer to Table 2-2 for a comprehensive listing of all valid HP-IB address codes.

Updating the HP-IB Address Display The HP-IB address display is continuously updated. When the switch setting is changed, the result is immediately visible on the display.

TALK and LISTEN Status Descriptions

Talk Only Mode If the internal address switches are set to a valid address and the TON (Talk Only) switch is set to "1", the Measuring Receiver is placed in the Talk Only mode. This mode causes the instrument to output data each time a measurement is made. Each time the measurement is completed, data will be output to the bus unless the listening device is not ready for data. If the listener is not ready, and the Measuring Receiver is in Free Run mode (T0), another measurement cycle is executed.

Talk Status Only Mode If the five internal address switches and the TON (Talk Only) switch are set to "1", the Measuring Receiver is placed in the Talk Status Only mode. In this mode the instrument is configured to send a one-byte data message whenever the bus is in the data mode. The byte sent is an exact copy of the Status Byte. Each time this byte is successfully sent on the bus, the internal Status Byte is cleared. The Data Valid (DAV) handshake line is pulsed each time the one-byte Data message is sent.

Listen Only Mode Listen Only mode is provided to allow the Measuring Receiver to accept programming from devices other than controllers (for example, card readers).

If the internal LON (Listen Only) switch is set to "1" and the TON (Talk Only) switch is set to "0", the Measuring Receiver is placed in the Listen Only mode when the remote enable bus control line (REN) is set true. The instrument then responds to all Data messages, and the Trigger, Clear, and Local Lockout messages. However, it is inhibited from responding to the Local or Abort messages and from responding to a serial poll with the Status Byte message.

Code Execution in the Measuring Receiver

Some things to consider when programming the HP 8902A are listed below. The following discussion of the Software Supervisor is included to elaborate on these considerations.

- Every two-letter command is acted upon, in order, in software state.
- Hardware State equals the Software State only after the end of the HP-IB code string AND a pause occurs allowing the instrument to implement the commands it has received (e.g., time delay between code strings when data is read from the instrument).
- Only one measurement mode may be loaded from Software state to Hardware state at a time; e.g., M2 D2 P1 H1 L2. For fail-safe operation, only use one measurement code per code string before reading a measurement back from the instrument. Refer to Table 3-13, "Measurement Modes and Codes" for a complete list of all the functions defined as Measurement Modes.
- Keyboard or HP-IB commands may not be implemented in hardware state during a measurement if the instrument decides the command is not significant to a particular measurement. Refer to Table 3-13, "Measurement Modes and Codes" and Table 3-14, "Measurement Modifiers" for more information.

The Software Supervisor is the program that controls overall instrument operation and controls the implementation of commands received from the external controller. (See Figure 3-5, "Software Supervisor Flowchart".) It is a loop that is continuously executed, with measurements made near the end after checks for proper frequency tuning, proper RF and IF level, and correct audio range. After arithmetic manipulation (e.g., for the RATIO function), the program loops back up to display the measurement.

The Software Supervisor controls the setup of the instrument for a measurement by making use of two concepts called Software State and Hardware State. Each of these is updated independently. The Software State is located in RAM and contains a software image of the state of the instrument. On power-up, the initialization procedure loads the initial Software State from ROM. (Refer to

"Instrument Preset" in the *Detailed Operating Instructions* on page 3-239 for a description of the initial instrument conditions.) The **Set Up Hardware** block in the supervisor is where the hardware state is made to conform with the software state.

The hardware state is the actual, current state of the internal settings of the instrument and is only updated when enough time is allowed between commands for the Software Supervisor measurement loop to be completed successfully without interruption; e.g., when a trigger is received.

The **Frequency Tuning**, **Signal Leveling**, and **Audio Ranging** blocks manipulate hardware as well and also verify that the instrument is adjusted to make an accurate measurement. A measurement is not made until all blocks are successfully completed in succession. If a block is not completed, a negative **Continue?** decision after that block then forces the program back to the top of the supervisor, bypassing the measurement for that loop.

In a normal, stable measurement cycle, the program takes the **Measurement Display** branch at the top of the supervisor and so avoids the extra time associated with the **Setup Hardware** block. However, if the program loops back before taking a measurement, or if an error condition exists, the **Non-Measurement Display** branch will be traversed. This will light an appropriate display, which is usually "- - -", and send the program back through the **Setup Hardware** block.

After power-up, the external system controller can be thought of as a medium through which the user requests a certain instrument setup which is first implemented in software state and then in hardware state. Controller commands (**Keyboard or HP-IB Interrupts**) are treated as non-returnable interrupts and break the flow around the Software Supervisor loop, forcing the internal microprocessor to execute a short program to change the software state and then return to the loop as shown in the diagram. The commands applicable to the measurement mode are implemented in software state and then in hardware state at the next **Setup Hardware**.

NOTE

Controller routines modify only the software state and do not affect the hardware immediately.

*Since a **Keyboard or HP-IB Interrupt** can interrupt the Supervisor at any point and return it to the point in the loop before **Set Up Hardware**, these interrupts abort the current measurement and start a new measurement cycle.*

*The actual instrument setup is guaranteed to conform to the Keyboard request only at the moment a measurement is taken (**Measure**).*

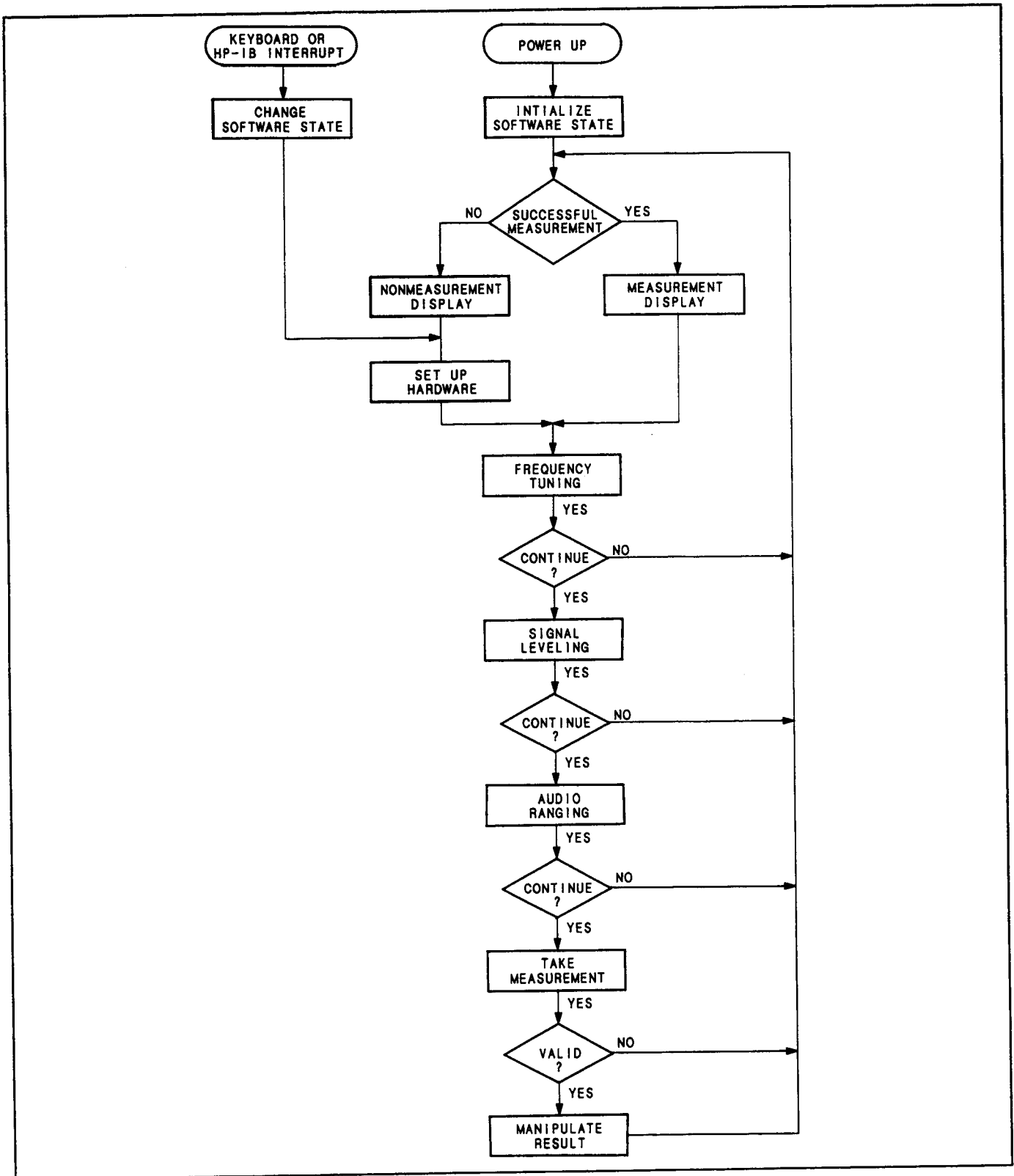

Figure 3-5. Software Supervisor Flowchart

Table 3-11. Measuring Receiver Function to Code Summary

Function	Code	Function	Code
MEASUREMENTS		CALIBRATION	
AM	M1	CALIBRATE Off	C0
FM	M2	CALIBRATE On	C1
ΦM	M3	% CAL FACTOR	CF
RF POWER	M4	SET REF	RF
FREQ	M5	ZERO	ZR
AUDIO FREQ	S1	SAVE CAL	SC
AUDIO DISTN	S2		
IF LEVEL	S3	MANUAL OPERATIONS	
TUNED RF LEVEL	S4	AUTO TUNING	AT
FREQ ERROR	S5	ENABLE ERRORS	B0
		DISABLE ERRORS	B1
DETECTORS		CLEAR (KEY)	CL
PEAK+	D1	DISPLAY FREQ	FR
PEAK-	D2	DISPLAY INCREMENT	FN
PEAK HOLD	D3	INPUT FREQUENCY (Hz)	HZ
AVG (RMS Calibrated)	D4	↑ Hz	HU
1 kHz DISTN	D5	↓ Hz	HD
400 Hz DISTN	D6	TRACK Mode Off (Lock Mode)	K0
RMS	D8	TRACK Mode On	K1
PEAK±/2	D9	↑ kHz	KU
		↓ kHz	KD
DISPLAYS		MHz (INPUT FREQ)	MZ
Display LOG Result	LG	RECALL	RC
Display LIN Result	LN	STORE	TR
dB EXT ATTEN off	N0	SPECIAL FUNCTION	SP
dB EXT ATTEN on	N1	SPECIAL, SPECIAL	SS
RATIO Off	R0	mV Units	MV
RATIO On	R1	μV Units	UV
PREVIOUS RATIO	R2	V Units	VL
		W Units	WT
FILTERS		MISCELLANEOUS	
HP (High-Pass) FILTERS Off	H0	MODULATION OUTPUT	A0
50 Hz FILTER On	H1	AUDIO INPUT	A1
300 Hz FILTER On	H2	AUTOMATIC OPERATION	AU
LP (Low-Pass) FILTERS Off	L0	Auto-Ranging (RANGE HOLD Off)	G0
3 kHz FILTER On	L1	RANGE HOLD	G1
15 kHz FILTER On	L2	Identify Instrument	ID
>20 kHz FILTER On	L3	INSTR PRESET (same as DCL)	IP
		Trigger Off	T0
FM DE-EMPHASIS		Hold	T1
PRE-DISPLAY Off and		Trigger Immediate	T2
FM DE-EMPHASIS Off	P0	Trigger with Settling	T3
PRE-DISPLAY On and		Hexadecimal A	X0
FM DE-EMPHASIS On	P1	Hexadecimal B	X1
25 μs DE-EMPHASIS	P2	Hexadecimal C	X2
50 μs DE-EMPHASIS	P3	Hexadecimal D	X3
75 μs DE-EMPHASIS	P4	Hexadecimal E	X4
750 μs DE-EMPHASIS	P5	Hexadecimal F	X5

Table 3-12. Code to Measuring Receiver Function Summary

Code	Function	Code	Function
A0	MODULATION OUTPUT	M1	AM
A1	AUDIO INPUT	M2	FM
AT	AUTO TUNING	M3	Φ M
AU	AUTOMATIC OPERATION	M4	RF POWER
B0	ENABLE ERRORS	M5	FREQ
B1	DISABLE ERRORS	MV	mV Units
C0	CALIBRATE Off	MZ	MHz (INPUT FREQ)
C1	CALIBRATE On	N0	dB EXT ATTEN Off
CF	% CAL FACTOR	N1	dB EXT ATTEN On
CL	CLEAR (KEY)	P0	PRE-DISPLAY Off and FM DE-EMPHASIS Off
D1	PEAK +	P1	PRE-DISPLAY On and DE-EMPHASIS On
D2	PEAK -	P2	25 μ s DE-EMPHASIS
D3	PEAK HOLD	P3	50 μ s DE-EMPHASIS
D4	AVG (RMS Calibrated)	P4	75 μ s DE-EMPHASIS
D5	1 kHz DISTN	P5	750 μ s DE-EMPHASIS
D6	400 Hz DISTN	R0	RATIO Off
D8	RMS	R1	RATIO On
D9	PEAK \pm /2	R2	PREVIOUS RATIO
FR	DISPLAY FREQ	RC	RECALL
FN	DISPLAY INCREMENT	RF	SET REF
G0	Auto-Ranging (RANGE HOLD Off)	S1	AUDIO FREQ
G1	RANGE HOLD	S2	AUDIO DISTN
H0	HP (High-Pass) FILTERS Off	S3	IF LEVEL
H1	50 Hz FILTER On	S4	TUNED RF LEVEL
H2	300 Hz FILTER On	S5	FREQ ERROR
HU	\uparrow Hz	SC	SAVE CAL
HD	\downarrow Hz	SP	SPECIAL FUNCTION
HZ	INPUT FREQUENCY (Hz)	SS	SPECIAL, SPECIAL
ID	Identify Instrument	T0	Trigger Off
IP	INSTR PRESET (same as DCL)	T1	Hold
K0	TRACK Mode Off (lock mode)	T2	Trigger Immediate
K1	TRACK Mode On	T3	Trigger with Settling
KU	\uparrow kHz	TR	STORE
KD	\downarrow kHz	UV	μ V Units
L0	LP (Low-Pass) FILTERS Off	VL	V Units
L1	3 kHz FILTER On	WT	W Units
L2	15 kHz FILTER On	X0	Hexadecimal A
L3	>20 kHz FILTER On	X1	Hexadecimal B
LG	Display LOG Result	X2	Hexadecimal C
LN	Display LIN Result	X3	Hexadecimal D
		X4	Hexadecimal E
		X5	Hexadecimal F
		ZR	ZERO

Table 3-13. Measurement Modes and Codes (1 of 2)

Measurement Mode	Program Code	Receiver Used?	Volatile?	Blanks Demod. Output?
AM	M1	Yes	No	No
AM Calibration	C0, C1	Yes	No	No
AM Calibration Actual	13.0SP	No	No	Yes
AM Residual Calibration	13.1SP	Yes	No	No
AM Peak Residual Calibration	13.2SP	Yes	No	No
Read AM Calibration Factor	16.2SP	No	Yes	No
FM	M2	Yes	No	No
FM Calibration	C0, C1	Yes	No	No
FM Calibration Actual	12.0SP	No	No	Yes
FM Residual Calibration	12.1SP	Yes	No	No
FM Peak Calibration	12.2SP	Yes	No	No
Read FM Calibration Factors	17.2SP	No	Yes	No
ΦM	M3	Yes	No	No
RF Power (Power Sensor)	M4	No	No	Yes
RF Power Zeroing	ZR	No	Yes	Yes
RF Power Calibration Factor Status	37.2SP	No	Yes	No
RF Power Calibration Factor Table Size	37.4SP	No	Yes	No
RF Level (RF Peak Detector)	35.XSP	No	No	Yes
Tuned RF Level	S4	Yes	No	Yes
Tuned RF Level (Synchronous and Average)	4.XSP	Yes	No	Yes
Peak Tuned RF Level	36.XSP	Yes	No	Yes
IF Level	S3	Yes	No	No
Frequency	M5	Yes	No	No
LO Frequency	33.XSP	Yes	No	No
IF Frequency	34.XSP	Yes	No	No
Frequency Error	S5	Yes	No	No
Audio				
Audio Frequency (External)*	S1 A2	No	No	Yes**
Audio Distortion (External)*	S2 A2	No	No	Yes**
Audio SINAD (External)*	29.0SP A2	No	No	Yes**
Audio RMS Level (External)	30.XSP	No	No	Yes**

* Use A1 to select internal audio measurements. Internal audio measurements use the Receiver.
 ** The demodulated Output is not blanked during internal Audio measurements.

Table 3-13. Measurement Modes and Codes (2 of 2)

Measurement Mode	Program Code	Receiver Used?	Volatile?	Blanks Demod. Output?
Other Measuring Capabilities				
Squelched Tone Receiver	18.XSP	Yes	Yes	No
Timebase Oven Hot/Cold	15.0SP	No	Yes	No
Timebase Internal/External	15.1SP	No	Yes	No
Reading Internal User Information				
HP-IB Address	21.XSP	No	Yes	No
Display Ext. LO Freq	27.2SP	No	Yes	No
Display Operator Selected Special Functions	SP	No	Yes	No
Display Instrument Selected Special Functions	SS	No	Yes	No
Display Ext. Atten.	25.2SP	No	Yes	No
HP-IB Identify (8901B or 8902A?)	ID	No	Yes	No
Display SRQ Mask	22.64SP	No	Yes	No
Software Date Code	42.XSP	No	Yes	No
Read Ratio Reference	11.2SP	No	Yes	No
Read Lower Limit	14.5SP	No	Yes	No
Read Upper Limit	14.6SP	No	Yes	No
Read Lower Limit Measurement Code	14.7SP	No	Yes	No
Read Upper Limit Measurement Code	14.8SP	No	Yes	No

Measurement and Code	Variable Parameters							
	Ranges	Detectors (D1-9)	Filters (H0-2 and L0-3)	De-emphasis (0-5)	Calibration Factors	Frequency Offset	dB Ext. Attenuator	Limit/ Ratio
AM Measurement (M1)	3 (2.XSP)	Peak (+ or -), Avg, or RMS	Yes	N/A	Yes	Tuning	N/A	Yes
AM Calibration (C0, C1 and CF)	N/A	Peak (+ or -)	N/A	N/A	Yes	N/A	N/A	N/A
AM Calibrator (13.XSP)	Fixes (2.XSP)	Peak (+ or -)	N/A	N/A	N/A	N/A	N/A	N/A
FM Measurement (M2)	4 (2.XSP)	Peak (+ or -), Avg, or RMS	Yes	Yes	Yes	Tuning	N/A	Yes
FM Calibration (C0, C1 and CF)	N/A	Peak (+ or -)	N/A	N/A	Yes	N/A	N/A	N/A
FM Calibrator (12.XSP)	Fixes (2.XSP)	Peak (+ or -)	N/A	N/A	N/A	N/A	N/A	N/A
ΦM Measurement (M3)	4 (2.XSP)	Peak (+ or -), Avg, or RMS	Yes	N/A	Yes (FM)	Tuning	N/A	Yes
RF Power Measurement (M4)	5* (10.XSP)	RF Power Sensor	N/A	N/A	Yes	Yes	Yes	Yes
Tuned RF Level Measurement (S4) (includes Synchronous and Average)	3 RF (1.XSP) + 1 (Power Sensor)	IF Synch., IF Avg. (4.XSP)	N/A	N/A	Yes	Tuning	Yes	Yes
Peak RF Level (35.XSP)	N/A	RF Peak	N/A	N/A	N/A	N/A	Yes	Yes
Peak Tuned RF Level (36.XSP)	N/A	IF Peak	N/A	N/A	N/A	Tuning	Yes	Yes
Set Reference (RF)	3 (1.XSP)	IF Synch., IF Avg. (4.XSP)	N/A	N/A	Yes	Tuning	Yes	Yes
IF Level Measurement (S3)	N/A	IF Avg	N/A	N/A	N/A	Tuning	N/A	Yes
* RF Power has two completely independent tables for calibration factors, one used in normal operation and one used when Frequency Offset mode is active.								
** 0.15-2.5 MHz, 2.5-10 MHz, and 10-1300 MHz.								

Table 3-14. Measurement Modifiers (1 of 2)

Table 3-14. Measurement Modifiers (2 of 2)

Measurement and Code	Variable Parameters							
	Ranges	Detectors (D1-9)	Filters (H0-2 and L0-3)	De-emphasis (0-5)	Calibration Factors	Frequency Offset	dB Ext. Attenuator	Limit/ Ratio
RF Frequency Measurement (M5)	3**	N/A	N/A	N/A	N/A	Yes	N/A	Yes
LO Frequency (33.XSP)	N/A	1	N/A	N/A	N/A	N/A	N/A	Yes
IF Frequency (34.XSP)	N/A	1	N/A	N/A	N/A	N/A	N/A	Yes
Frequency Error Measurement (S5)	3**	N/A	N/A	N/A	N/A	Tuning	N/A	Yes
Audio Measurements								
Audio Frequency (S1)	N/A	N/A	N/A	N/A	N/A	Tuning	N/A	Yes
Audio Distortion (S2)	N/A	RMS	Yes	Yes (FM)	N/A	Tuning	N/A	Yes
External Audio RMS Level (30.XSP)	N/A	RMS	N/A	N/A	N/A	N/A	N/A	Yes
SINAD (29.XSP)	N/A	RMS	Yes	Yes (FM)	N/A	Tuning	N/A	Yes
** 0.15-2.5 MHz, 2.5-10 MHz, and 10-1300 MHz.								

Table 3-15. Enabling/Disabling Variable Parameters (Front Panel)

Parameter and Code	Default Value	To See Value/s	To Re-enable	Dis-able	To See Status	To Enter Value and Enable	Misc.
Calibration Factors							
AM (16.XSP)	100%	16.2SP, or AM/ % Cal Factor *	16.1SP	16.0SP	AM % Cal Factor *	AM/ CAL/ SAVE CAL	N/A
FM (17.XSP)	100%	17.2SP, or FM/ % Cal Factor *	17.1SP	17.0SP	FM/ % Cal Factor *	FM/ CAL/ SAVE CAL	N/A
RF Power ** (37.XSP)	N/A	RF Power/ %Cal Factor *	37.0SP (Automatic) 37.1SP (Manual)	Auto Op, or 37.0SP	37.2SP	RF Power/ nnn/ % Cal Factor, or 37.1SP	37.3-6, 9SP (edit CF Tables)
Tuned RF Level (38.XSP and 39.XSP)	ROM Table	38.1-3SP/ or Tuned RF Level/ %Cal Factor *	Freq back to valid point (Valid) 39.9SP (Default)	Change freq.,	Uncal light, or Tuned RF Level/ % Cal Factor *	Tuned RF Level/ CAL or 39.1, 2, 3SP	N/A
Frequency Offset (27.XSP)	0 MHz	27.2SP	27.1SP	27.0SP	f OFS light	27.3SP/ nn/ MHz	N/A
dB External Attenuation (25.XSP)	0 dB	25.2SP	dB EXT ATTEN	dB EXT ATTEN	dB Ext Atten Light	nn/dB EXT ATTEN	N/A
Ratio (11.XSP)	100	11.2SP	Previous Ratio	Ratio Key	Ratio Key Light	Ratio Key/ or nnn/ Ratio Key	N/A
Limits (14.XSP)	0.15 and 1300 (Code 5=freq)	14.5SP, or 14.6SP	14.3SP, or 14.4SP	14.0SP	14.9SP	14.1SP, or 14.2SP (from Ratio)	14.7SP, or 14.8SP (measurement mode)
Set Reference (26.XSP)	0 dBm	N/A	26.1SP	Tuned RF Level, or 26.0SP	dB Annunciator	Tuned RF Level/ Set Ref.	N/A

* % Cal Factor alone shows the value currently being used. For AM, FM, and Synch. and Avg. Tuned RF Level, it also indicates enabled/disabled status by display resolution. 0.01% resolution indicates enabled and 1% resolution indicates disabled.

** Two tables of RF Power Calibration Factors are available. The table being used is determined by the status of the Frequency Offset Mode.

Table 3-16. Enabling/Disabling Variable Parameters (Remote)

Parameter and Code	Default Value	To See Value/s	To Re-enable	Dis-able	To See Status	To Enter Value and Enable	Misc.
Calibration Factors							
AM (16.XSP)	100%	16.2SP or M1 CF *	16.1SP	16.0SP	M1 CF *	M1 C1 SC	N/A
FM (17.XSP)	100%	17.2SP or M2 CF *	17.1SP	17.0SP	M2 CF *	M2 C1 SC	N/A
RF Power ** (37.XSP)	N/A	M4 CF *	37.0SP (Automatic) 37.1 (Manual)	AU or 37.0SP	37.2SP	M4 nnn CF or 37.1SP	37.3-6, 9SP (edit CF Tables)
Tuned RF Level (38.XSP and 39.XSP)	ROM Table	38.1-3SP or S4 CF *	Freq set to valid point (Valid) 39.9SP (Default)	Change freq.	Uncal light, or S4 CF *	S4 C1 or 39.1, 2, 3SP	N/A
Frequency Offset (27.XSP)	0 MHz	27.2SP	27.1SP	27.0SP	f OFS light	27.3SP nn MZ	N/A
dB External Attenuation (25.XSP)	0 dB	25.2SP	N1	N0	dB Ext Atten Light	nn N1	N/A
Ratio (11.XSP)	100	11.2SP	R2	R0	Ratio Key Light	R1 or nnn R1	N/A
Limits (14.XSP)	0.15 and 1300 (Code 5=freq)	14.5SP, or 14.6SP	14.3SP, or 14.4SP	14.0SP	14.9SP	14.1SP, or 14.2SP (from Ratio)	14.7SP, or 14.8SP (measurement mode code)
Set Reference (26.XSP)	0 dBm	N/A	26.1SP	S4 or 26.0SP	dB Annunciator	S4 RF	N/A

* % Cal Factor alone shows the value currently being used. For AM, FM, and Synch. and Avg. Tuned RF Level, it also indicates enabled/disabled status by display resolution. 0.01% resolution indicates enabled and 1% resolution indicates disabled.

** Two tables of RF Power Calibration Factors are available. The table being used is determined by the status of the Frequency Offset Mode.

Table 3-17. HP 8901A/02A Code Differences

HP 8901A	HP 8902A	Functions
A1 (or AU)	AU	AUTOMATIC OPERATION
F1 (or MZ)	MZ	MHz (INPUT FREQ)
F2 (or KU)	KU	↑ kHz
F3 (or KD)	KD	↓ kHz
F4 (or Z4 or SP)	SP	SPECIAL
F5 (or Z5 or SS)	SS	SPECIAL, SPECIAL
K1 (or CL)	CL	CLEAR
U1 (or D1)	D1	PEAK+
U2 (or D2)	D2	PEAK-
U3 (or D3)	D3	PEAK HOLD
U4 (or D4)	D4	Average Detector (RMS Calibrated)
Z1 (or HZ)	HZ	Hz INPUT FREQ
Z2 (or HU)	HU	↑ Hz
Z3 (or HD)	HD	↓ Hz
M4	35.0SP	Peak RF Level
S4	36.0SP	Peak Tuned RF Level
R1	LN, R1	% RATIO
R2	LG, R1	dB RATIO
4.0SP	AT, K0	Auto Tuning, low-noise lock mode
4.1SP	AT, K1	Auto Tuning, track mode
4.2SP	MZ, K0	Manual Tuning, low-noise lock mode
7.1SP	7.1SP	10 Hz frequency resolution
7.2SP	7.3SP	1000 Hz frequency resolution
9.0SP	G1	Hold Setting (RANGE HOLD)
10.0SP	34.0SP	IF Frequency
11.0SP	LN, R2	% PREVIOUS RATIO
11.1SP	LG, R2	dB PREVIOUS RATIO
11.3SP	use "-" key	Make Ratio Reference Negative
15.0SP	15.0SP	Oven Check (returns "0" if oven OK or not installed, rather than doing nothing as in the 8901A)
Status Byte	Status Byte	Status Byte Bits "Upper Limit" (weight 8) and "Lower Limit" (weight 16) are merged together into "Limit Reached" (weight 8)

3-12. BASIC FUNCTIONAL CHECKS OF THE MEASURING RECEIVER

Description

Using a signal generator, an oscilloscope, and a sensor module, the overall operation of the Measuring Receiver is verified.

Equipment

Oscilloscope	HP 1740A
Sensor Module	HP 11722A
Signal Generator	HP 8640B Option 001 and 002

The HP 8656B, HP 8662A, HP 8663A, HP 8654A or HP 8654B can also be used if an HP 8640B Option 001 and 002 is not available. However, with these other signal generators you will need to modify some tests.

Procedure

Preliminary Check

1. Connect the multi-conductor cable of the sensor module to the SENSOR input connector. Connect the RF coaxial cable of the sensor module to the INPUT 50Ω connector (see Figure 3-6). Select INSTR PRESET (Blue Key, AUTOMATIC OPERATION). Observe the front-panel LED annunciators, display segments and decimal points, and key lights. All LEDs should light for approximately 10 seconds at turn on and then all should momentarily turn off.
2. After the turn-on sequence, the instrument should display "--". The MHz annunciator, the FM annunciator under MODULATION OUTPUT, the AUTO TUNING annunciator (under the TRACK MODE key), and the FREQ key should be lighted.

RF Power Calibration Check

3. Connect the sensor module input to the RF POWER CALIBRATION OUTPUT connector. (See Figure 3-6.)

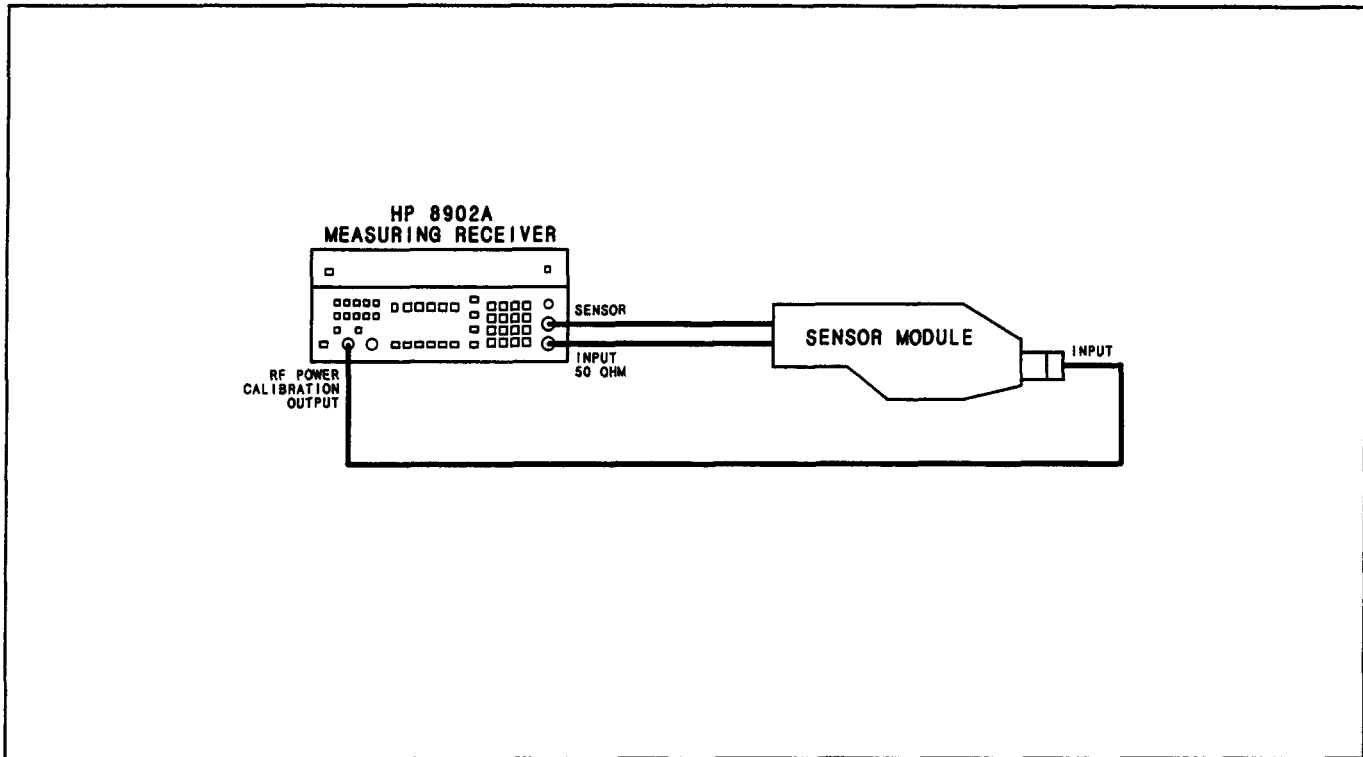

Figure 3-6. RF Power Calibration Setup

4. Press the RF POWER key. If the instrument does not display Error 15, proceed with step 6. If the instrument displays Error 15 (indicating the RF power calibration factors have not been entered), proceed with step 5.
5. If the instrument displays Error 15, enter the RF power calibration factors that are given on the cover of the sensor module. (Note that a software driven alternative is available. See *RF Power* for a program list in BASIC for the HP Series 200 computers.):
 - a. Enter the reference calibration factor by keying in 37.3 and pressing the SPCL key. Then, key in the value of the reference calibration factor and press the Blue key then the % CAL FACTOR key (the MHz key).
 - b. Enter each frequency/calibration factor pair by first keying in 37.3 and pressing the SPCL key. Next, key in the frequency (in MHz) and press the MHz key. Then, key in the value of the calibration factor and press the Blue key then the % CAL FACTOR key.

NOTE

Error 15 will continue to be displayed until the Measuring Receiver is able to interpolate between a frequency/calibration factor pair from those pairs entered. (For more information, refer to RF Power Calibration and RF Power Calibration Factors in the Detailed Operating Instructions in this section.)

6. Press the ZERO key. “— — — —” should be displayed for approximately 15 seconds, 0.0 00 W should then be displayed briefly, and then a value less than 3.0×10^{-6} W (that is, $3.0 \mu\text{W}$) should be displayed. (Ignore the RECAL and UNCAL annunciators if they are displayed.)
7. Press the CALIBRATE key. When a value appears in the display, press the Blue key and SAVE CAL key (the CALIBRATE key). The display should show between 0.999×10^{-3} and 1.000×10^{-3} W (that is, 0.999 and 1.000 mW) or between 999×10^{-6} and 1000×10^{-6} W (that is, 999 and 1000 μW). The RECAL and UNCAL annunciators should be off. Turn off the calibrator by pressing the CALIBRATE key again.

RF Power Check

8. Set the signal generator to 100 MHz CW at -10 dBm (as measured on its level meter).
9. Connect the input of the sensor module to the RF output of the signal generator. Connect the MODULATION OUTPUT/AUDIO INPUT to the vertical input of the oscilloscope. (See Figure 3-7.)

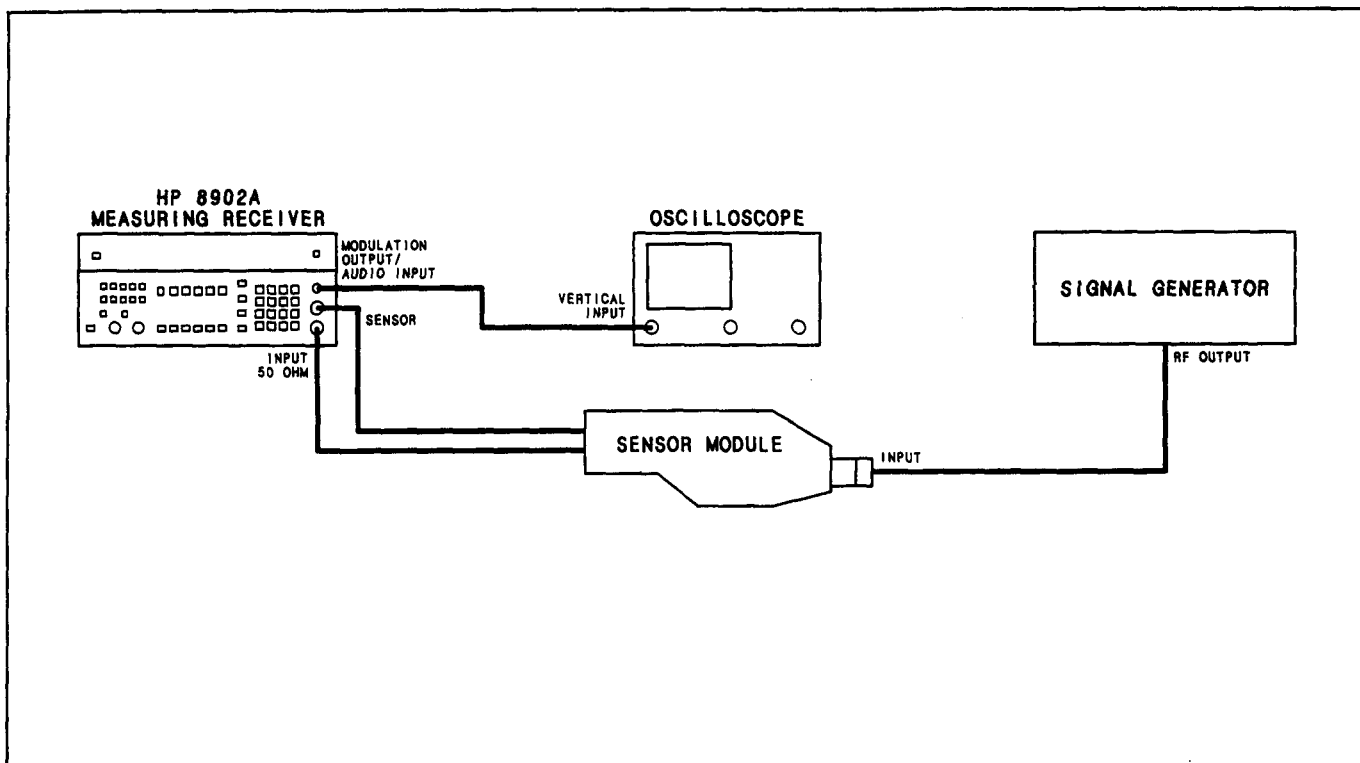

Figure 3-7. RF Power Check Setup

10. Press the LOG/LIN key to display power in dBm. The Measuring Receiver should display between -11.00 and -9.00 dBm.

RF Peak Level Check

11. Key in 35.0 and press the SPCL key (uses a peak detector to measure power). The Measuring Receiver should display between -16.00 and -6.00 dBm.

Frequency Check

12. Press the FREQ key. Key in 7.1 and press the SPCL key to set the RF frequency resolution to 10 Hz. Set the signal generator's frequency as shown in the following table. For each frequency, allow the Measuring Receiver to tune to the signal then compare the signal generator's frequency display with the Measuring Receiver's display. The two displays should agree within the limits indicated.

Signal Generator Frequency (MHz)	Frequency Difference Limits (\pm Hz)
2	40
4	50
8	70
16	100
25	130
50	230
100	430
200	830
400	1600
800	3200

13. Set the signal generator frequency to 50 MHz. When the Measuring Receiver has tuned to the signal, press the MHz key to disable the automatic tuning and enable manual tuning. Press the S (Shift) key and the FREQ ERROR key (the FREQ key). The Measuring Receiver should display between -1 and 1 kHz.
14. Key in 100 and press the \uparrow kHz key. The Measuring Receiver should display between -101 and -99 kHz. Key in 7.0 and press the SPCL key to return the RF frequency resolution to automatic selection.

Track Mode Tuning Check

15. Press the AUTOMATIC OPERATION key then the FREQ key. Press the TRACK MODE key. Manually sweep the signal generator's frequency to 64 MHz. The Measuring Receiver's frequency display should track the frequency as it changes. Press the TRACK MODE key again to turn off the function.

AM and FM Calibration Check

16. Connect the input of the sensor module to the AM/FM CALIBRATION OUTPUT connector. (See Figure 3-8.)

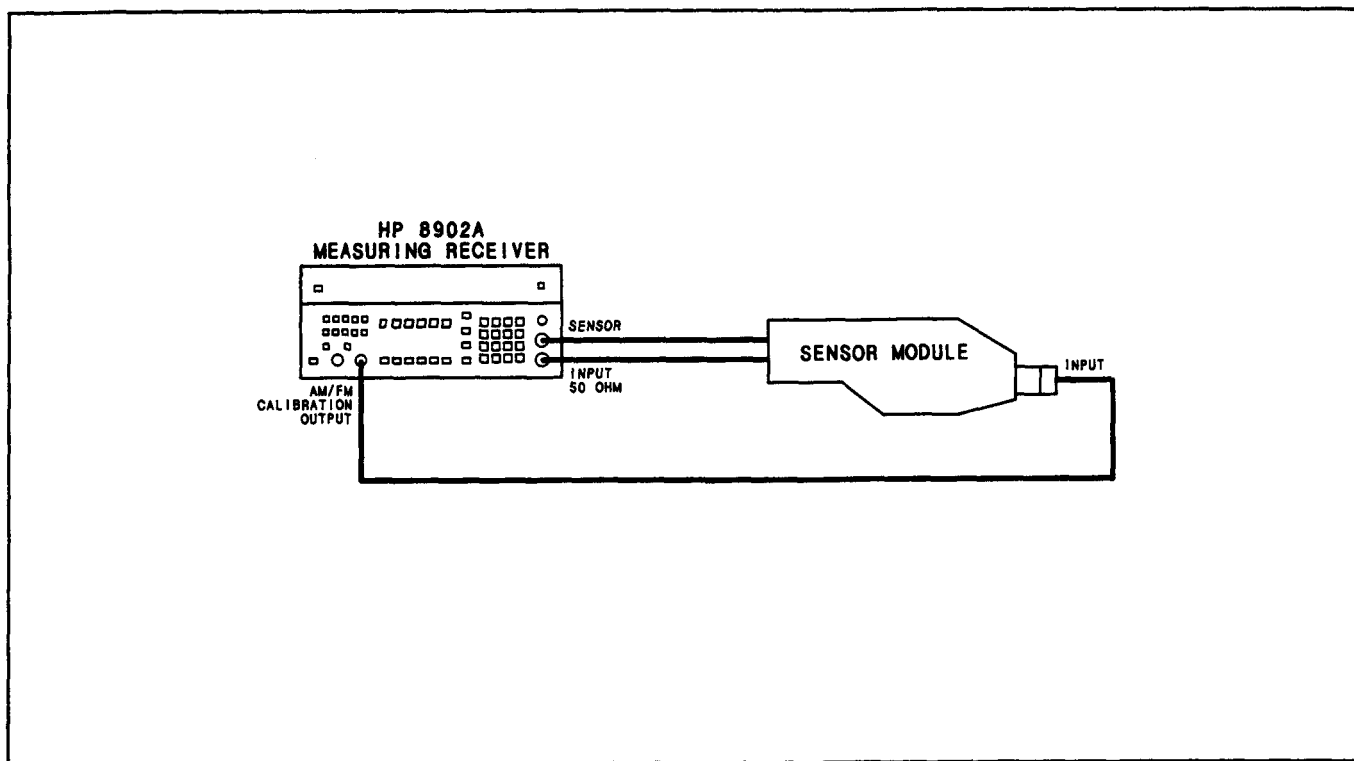

Figure 3-8. AM and FM Calibration Check Setup

17. Press the AM key then the CALIBRATE key. After approximately 20 seconds, the AM calibration factor should be displayed. The displayed value should be between 99.00 and 101.00%.
18. Press the FM key then CALIBRATE key. After approximately 20 seconds, the FM calibration factor should be displayed. The displayed value should be between 99.00 and 101.00%. Press the CALIBRATE key again to turn off FM calibration. (If you remove the sensor with the calibrator still on it might return Error 08.)

AM Check

19. Reconnect the sensor module input to the signal generator's output. (See Figure 3-9.)

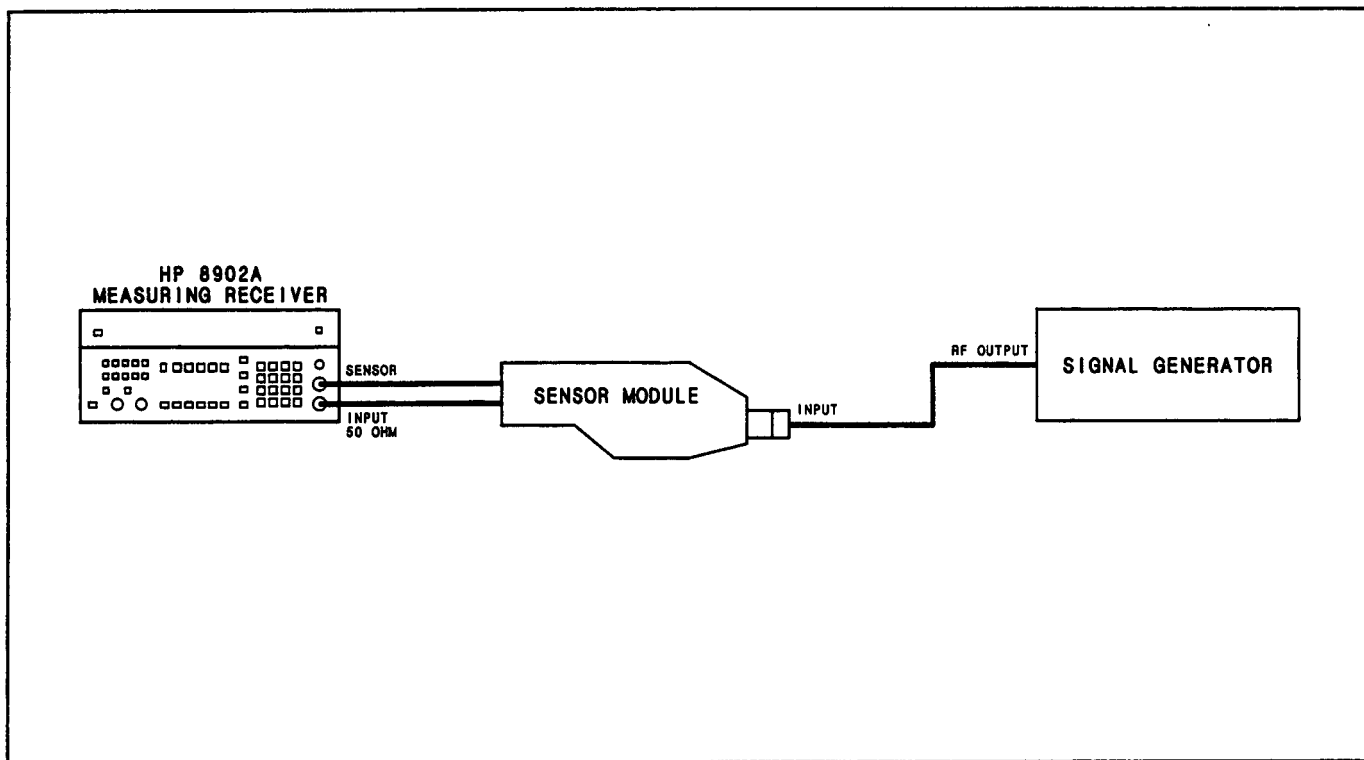

Figure 3-9. AM Check Setup

20. Press the Measuring Receiver's MHz key. Set the signal generator for 50% AM (as measured on its AM meter) at a 1 kHz rate.
21. Press the AM key. The Measuring Receiver should display between 46.0 and 54.0%.
22. Set the signal generator's AM to 25% (as measured on its AM meter). The Measuring Receiver should display between 22.00 and 28.00% with 0.01% resolution.

FM and Phase Modulation (Φ M) Checks

23. Set the signal generator's AM off and set FM to 50 kHz peak deviation (as measured on its FM meter) at a 1 kHz rate. Press the FM key. The Measuring Receiver should display between 45.0 and 55.0 kHz.
24. Adjust the signal generator's FM peak deviation for 50 kHz as displayed by the Measuring Receiver.
25. Press the Φ M key. The instrument should display between 45.0 and 55.0 rad.

FM De-emphasis Check

26. Press the FM key. Press the RATIO key. If the display is in dB, press the LOG/LIN key to display %. The instrument should display between 99.8 and 100.2% REL. The oscilloscope should show a sinusoidal waveform with a peak-to-peak amplitude between 0.9 and 1.1V and a period of 1 ms.
27. Press the LOG/LIN key. Press the RATIO key. Press the PRE-DISPLAY key. Set the FM rate as listed in the following table. For each setting, perform the following steps:
 - a. Set the FM DE-EMPHASIS off if it is on. (Leave PRE-DISPLAY on.)
 - b. Set the signal generator's FM modulation rate to a value approximate to that listed in the table.
 - c. Press the RATIO key to establish a reference of 0 dB.
 - d. Press the FM DE-EMPHASIS time constant key listed in the table.
 - e. Adjust the modulation rate (but not the level) until the displayed modulation is -3.0 dB.
 - f. Press the S (Shift) key then press the AUDIO FREQ key (the AM key). The Measuring Receiver should display a rate within the limits listed. Also, the oscilloscope waveform should change proportionately with the display. (Allow for a times 10 amplitude at the output of MODULATION OUTPUT/AUDIO INPUT when FM DE-EMPHASIS is set to 750 μ s.)

Approximate FM Modulation Rate (Hz)	FM DE-EMPHASIS Time Constant (μ s)	Frequency Limits (Hz)	
		Minimum	Maximum
6366	25	6175	6557
3183	50	3088	3278
2122	75	2058	2187
212	750	205.8	218.7

Audio Frequency and Audio Filters Check

28. Set FM DE-EMPHASIS and PRE-DISPLAY off. Set the FM rate as listed in the following table. For each setting, perform the following steps:
 - a. Set the HP FILTER and LP FILTER to ALL OFF.
 - b. Set the signal generator's FM rate as listed in the table.
 - c. Press the FM key then press the RATIO key to establish a reference of 0 dB.
 - d. Set the HP or LP FILTER as listed in the table, and fine adjust the FM rate for a reading of -3.0 dB REL.
 - e. Press the S (Shift) key then the AUDIO FREQ key and note the FM rate. The Measuring Receiver should display a rate within the limits listed.

Approximate FM Modulation Rate (Hz)	HP or LP Filter	Frequency Limits (Hz)	
		Minimum	Maximum
50	50 Hz HP	47.5	52.5
300	300 Hz HP	285	315
3 000	3 kHz LP	2 850	3 150
15 000	15 kHz LP	14 250	15 750
90 000	>20 kHz LP	80 000	140 750

Audio Distortion and SINAD Check

29. Press the AM key and set the LP FILTER to ALL OFF. Set the signal generator's FM off, and set the AM depth to 50% (as measured on the Measuring Receiver's display) at a 1 kHz rate. Press the S (Shift) key then the AUDIO DISTN key (the FM key). The displayed distortion should be less than 3%. (The display should also indicate 1 kHz. If 400 Hz is displayed, press the Blue key then the 400 Hz DISTN key (the PEAK- key).)
30. Set the signal generator's AM for a 400 Hz rate. Press the Blue key then the 400 Hz DISTN key (the PEAK- key). The displayed distortion should be less than 3%.
31. Press the LOG/LIN key to display the distortion in dB. Key in 29.0 and press the SPCL key. The displayed SINAD should be greater than 30 dB.

External Audio RMS Level Check

32. Connect the audio (AM or trigger) output of the signal generator to the input of the oscilloscope. (See Figure 3-10.) Set the signal generator's audio output level for 3 V_{pp} as read on the oscilloscope.

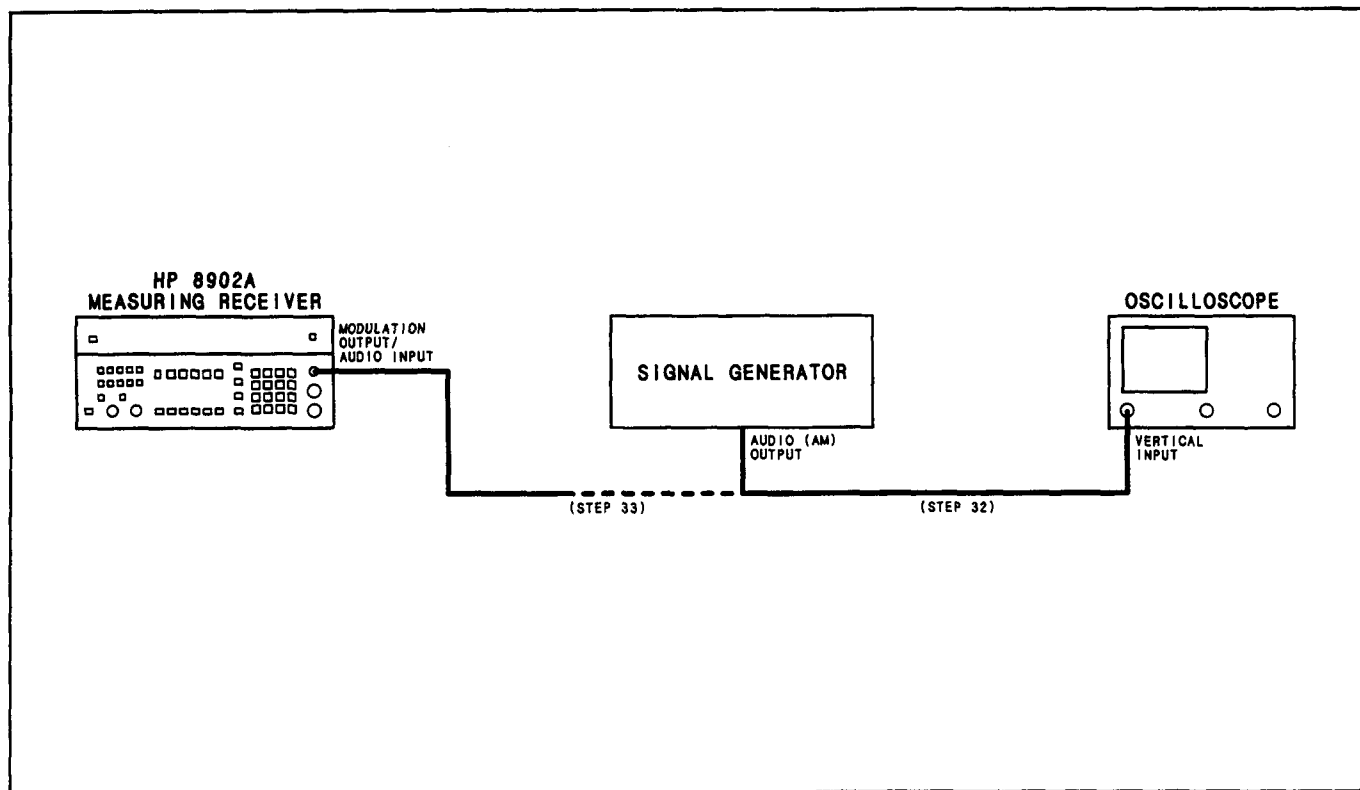

Figure 3-10. External Audio RMS Level Check Setup

33. Connect the audio output of the signal generator to the MODULATION OUTPUT/AUDIO INPUT of the Measuring Receiver. (See step 33 of Figure 3-10.) Key in 30.0 and press the SPCL key. If the display is in dB V, press the LOG/LIN key to display V. The Measuring Receiver's displayed level should be between 0.95 and 1.17V.

Audio Detector Check

34. Disconnect the signal generator's audio output. Press the FM key. Set the signal generator's AM off and set the FM on with a peak deviation of 50 kHz and a rate of 1 kHz. Press the RATIO key then the LOG/LIN key to % to establish a reference of 100%. Set DETECTOR to PEAK-. The Measuring Receiver should display between 95 and 105% REL depending upon the signal generator's FM distortion.
35. Set DETECTOR to PEAK±/2 by pressing both the PEAK+ and PEAK- keys simultaneously. The Measuring Receiver should display a value between 100% and the value read in step 34.
36. Press the AVG key. The instrument should display between 69.3 and 72.1% REL. Turn the ratio function off by pressing the RATIO key again.
37. Press the PEAK+ key then press the PEAK HOLD key. Switch the signal generator's FM off. The Measuring Receiver's display should retain the largest value obtained after pressing PEAK HOLD. Turn off the peak hold function by pressing the PEAK+ key.

IF Level Check

38. Press the S (Shift) key then the IF LEVEL key (the ΦM key). The Measuring Receiver should display between 99.9 and 100.1%.

IF Frequency and LO Frequency

39. Set the signal generator to 100.000 MHz CW at 0 dBm. (Accurately set its frequency.) Press the AUTOMATIC OPERATION key then key in 34.0 and press the SPCL key to display the IF frequency. The frequency displayed should be between 1.45 and 1.55 MHz.
40. Key in 33.0 and press the SPCL key to display the LO frequency. The frequency displayed should be between 101.45 and 101.55 MHz.
41. Key in 3.1 and press the SPCL key. (Special Function 3.1 switches the IF bandwidth back to 455 kHz.) The frequency displayed should be between 100.44 and 100.46 MHz.

Peak Tuned RF Level and RF High-Pass Filter Check

42. Set the signal generator to 5.25 MHz CW at 0 dBm. Key in 36.0 and press the SPCL key. The display should read between 0.500 and 2.000 -03 W (that is, between 0.5 and 2 mW).
43. Press the RATIO key. If the display is in % REL, press the LOG/LIN key to display dB REL. Key in 3.3 and press the SPCL key (to insert the RF high-pass filter). The Measuring Receiver should display between -2 and -8 dB REL. Turn off the ratio function by pressing the RATIO key again. Key in 3.0 and press the SPCL key to return the RF high-pass and IF filter selection to automatic.

Synchronous and Average Tuned RF Level Check

44. Set the signal generator for 20 MHz CW at 0 dBm. Press the S (Shift) key then the TUNED RF LEVEL key (the RF POWER key) to measure the signal using the IF synchronous detector. When the Measuring Receiver displays a reading, press the MHz key. Press the CALIBRATE key. Adjust the signal generator's level so the Measuring Receiver displays 0.00 dBm.

45. Step down the signal generator's level in 10 dB steps as listed in the following table. When the RECAL annunciator is displayed, press the CALIBRATE key while keeping the signal generator's level constant. At each step the Measuring Receiver's display should be within the limits indicated in the table.

Signal Generator Output Level (dBm)	Display Limits (dBm)	
	Minimum	Maximum
-10	-10.06	-9.94
-20	-20.12	-19.88
-30	-30.27	-29.73
-40	-40.48	-39.52
-50	-50.75	-49.25
-60	-61.08	-58.92
-70	-71.68	-68.53
-80	-81.92	-78.08
-90	-92.43	-87.57
-100	-103.00	-97.00

46. Return the level of the signal generator to 0.00 dBm. Key in 4.4 and press the SPCL key to measure the signal using the IF average detector. Press the CALIBRATE key. Set the signal generator's level so the Measuring Receiver displays 0.00 dBm.
47. Step down the level of the signal generator, in 10 dB steps, using the same measurement limits as in the previous table.

Error Check

48. Set the signal generator to 200 MHz CW at 0.0 dBm. On the Measuring Receiver, press the AUTOMATIC OPERATION key then press the FM key. Press the PEAK+ key. After the Measuring Receiver is tuned, press the RANGE HOLD key. Key in 100 then press the ↑ kHz key. The Measuring Receiver should display Error 01. Press the RANGE HOLD key again to turn off the function.
49. Press the ↓ kHz key. Key in 2.1 and press the SPCL key. Set the signal generator's FM on and adjust the peak deviation for 5 kHz (as read on its FM meter). The Measuring Receiver should display Error 04.
50. Key in 8.4 and press the SPCL key. The instrument should display Error 07.

High-Selectivity Level Check (Option Series 030)

51. Set the signal generator to 10 MHz CW at 0.0 dBm. On the Measuring Receiver, press the Blue key then press the INSTR PRESET key (the AUTOMATIC OPERATION key) to preset the instrument. Key in 24.0 then press the SPCL key to initialize the high-selectivity level measurement.
52. Key in 24.1 then press the SPCL key. Slowly fine tune the signal generator up and down until a maximum level is found. At that frequency key in 24.2 then press the SPCL key. (This establishes an IF level reference.)
53. Slowly fine tune the signal generator down until the Measuring Receiver displays -6.0 dB. Note the signal generator's frequency.

54. Slowly fine tune the signal generator up until the Measuring Receiver again displays -6.0 dB. Subtract the displayed frequency from the frequency of step 53. The difference should be between the limits shown in the following table for the option combination given.

Option Combination	Frequency Difference Limits (kHz)	
	Minimum	Maximum
032 and 035 033 and 035 035 and 037	25.0	35.0
032 and 033 033 and 037	12.4	16.9
032 and 037	6.4	10.4

55. On the Measuring Receiver, press the Blue key then press the INSTR PRESET key. Key in 24.0 then press the SPCL key.
56. Key in 24.3 then press the SPCL key. Slowly fine tune the signal generator up and down until a maximum level is found. At that frequency key in 24.4 then press the SPCL key. (This establishes an IF level reference.)
57. Slowly fine tune the signal generator down until the Measuring Receiver displays -6.0 dB. Note the signal generator's frequency.
58. Slowly fine tune the signal generator up until the Measuring Receiver again displays -6.0 dB. Note the signal generator's frequency. Subtract the displayed frequency from the frequency of step 57. The difference should be between the limits shown in the following table for the option combination given.

Option Combination	Frequency Difference Limits (kHz)	
	Minimum	Maximum
032 and 037 033 and 037 035 and 037	2.0	3.0
032 and 033 032 and 035	6.4	10.4
033 and 035	12.4	16.9

59. Fine tune the signal generator for a reading of 0.0 dB. Step down the signal generator's level in 10 dB steps as listed in the following table. At each step the Measuring Receiver's display should be within the limits indicated in the table.

Signal Generator Output Level (dBm)	Display Limits (dB)	
	Minimum	Maximum
-10	-11.0	-9.0
-20	-21.0	-19.0
-30	-31.0	-29.0
-40	-41.0	-39.0
-50	-51.0	-49.0
-60	-61.0	-59.0
-70	-71.0	-69.0
-80	-81.0	-79.0
-90	-91.0	-89.0

External LO Check (Option Series 030)

60. Set the signal generator to 51.50 MHz CW at 0 dBm. Connect the signal generator's output to the rear-panel LO INPUT connector. Connect the sensor module's input to CALIBRATION RF POWER OUTPUT connector. (See Figure 3-11.)

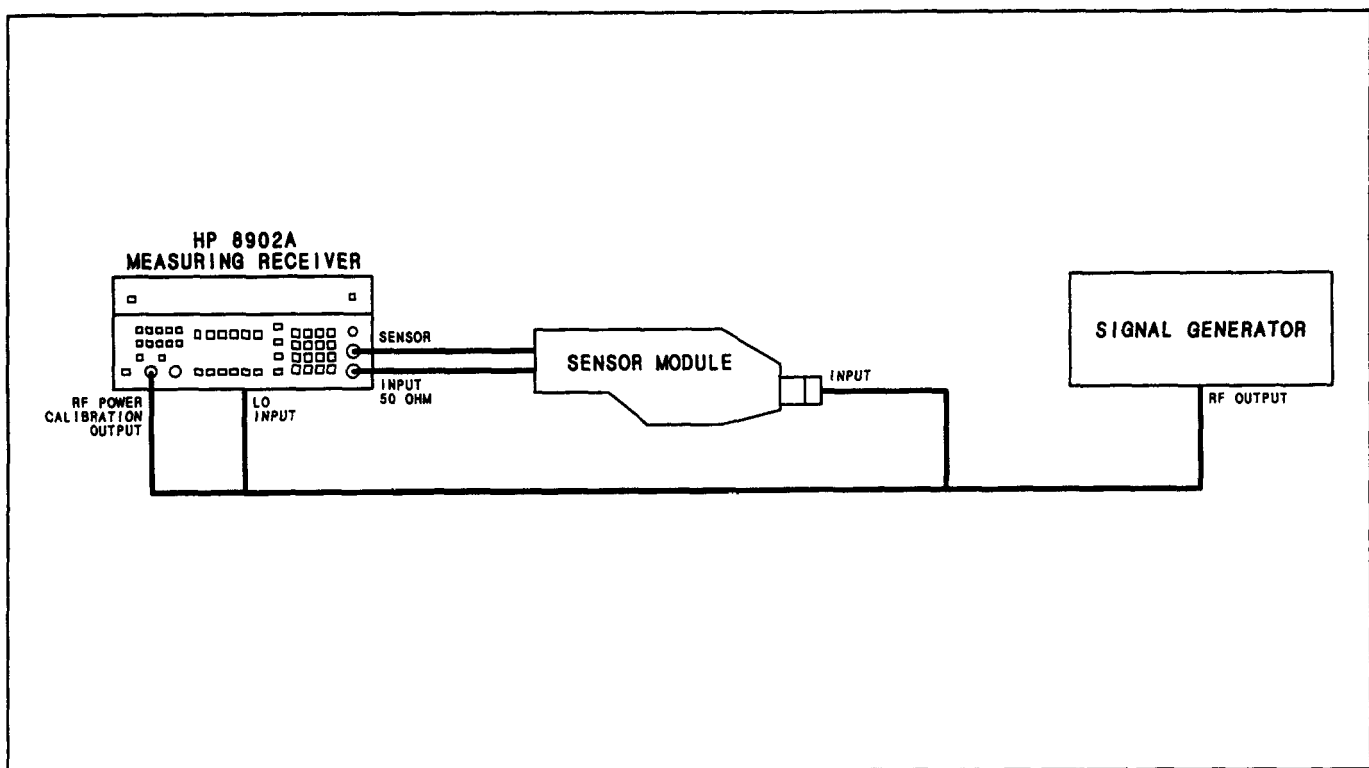

Figure 3-11. External Lo Check (Option 030) Setup

61. On the Measuring Receiver, key in 45.16 and press the SPCL key then key in 23.1 SPCL and press the SPCL key. (This turns on the RF power calibrator and switches the LO to external.) Key in 50 then press the MHz key. The display should read between 48 and 52 MHz.

3-13. BASIC FUNCTIONAL CHECKS OF THE HEWLETT-PACKARD INTERFACE BUS (HP-IB)

Description

The following ten procedures check the Measuring Receiver's ability to process or send all of the applicable HP-IB messages described in paragraphs 3-12 through 3-31. In addition, the Measuring Receiver's ability to recognize its HP-IB address is checked and all of the bus data, handshake and control lines except DIO8 (the most significant data line which is not used by the Measuring Receiver) are set to both their true and false states. These procedures do not check whether or not all Measuring Receiver program codes are being properly interpreted and executed by the instrument; however, if the front panel operates as expected, the program codes, in all likelihood, will be correctly implemented.

The validity of these checks is based on the following assumptions:

- The Measuring Receiver performs properly when operated via the front-panel keys (that is, in local mode). This can be verified with the preceding Basic Functional Checks of the Measuring Receiver in paragraph 3-11.
- The bus controller properly executes HP-IB operations.
- The bus controller's HP-IB interface properly executes the HP-IB operations.

If the Measuring Receiver appears to fail any of these HP-IB checks, the validity of the above assumptions should be confirmed before attempting to service the instrument.

The select code of the controller's HP-IB interface is assumed to be 7. The address of the Measuring Receiver is assumed to be 14 (its address as set at the factory). This select code-address combination (that is, 714) is not necessary for these checks to be valid. However, the program lines presented here would have to be modified for any other combination.

These checks are intended to be as independent of each other as possible. Nevertheless, the first four checks should be performed in order before other checks are selected. Any special initialization or requirements for a check are described at its beginning.

Initial Setup

The test setup is the same for all of the checks. Connect the Measuring Receiver to the bus controller via the HP-IB interface. Do not connect any equipment to any of the Measuring Receiver's input connectors.

Equipment

HP-IB Controller HP 9825A/98213A(General and Extended I/O ROM)
 or HP 9835A/98332A(I/O ROM)
 or HP 9845A(with HP-IB capability)
 HP-IB Interface.....HP 98034A (use "revised" version with 9835A and 9845A)

The HP 9825A uses HPL. The HP 9835A and HP 9845A use BASIC. You can also use HP Series 200 Controllers which use BASIC. (Code differences exist between the BASIC used by the HP 9835A and HP 9845A and the BASIC used by the HP Series 200 Controllers. These code differences are specified in the procedure.)

Procedures

Using the table of instructions under each function, read the description of the purpose of the commands and then enter the commands appropriate to your controller exactly as described. Check that the instrument responds correctly.

Address Recognition Check

This check determines whether or not the Measuring Receiver recognizes when it is being addressed and when it is not. This check assumes only that the Measuring Receiver can properly handshake on the bus. Before beginning this check, set the Measuring Receiver's POWER switch to STBY, then to ON.

Description	HPL	BASIC
Set the Remote Enable (REN) bus control line false.	lcl 7	LOCAL 7
Send the Measuring Receiver's listen address.	wrt 714	OUTPUT 714
Check that the Measuring Receiver's LISTEN annunciator is on.		
Unaddress the Measuring Receiver by sending a different address	wrt 715	OUTPUT 715
Check that the Measuring Receiver's LISTEN annunciator is turned off.		

Remote/Local Messages and the LOCAL Key Check

This check determines whether the Measuring Receiver properly switches from local to remote control, from remote to local control, and whether the LOCAL key returns the instrument to local control. This check assumes that the Measuring Receiver is able to both handshake and recognize its own address. Before beginning this check, select 40.0 SPCL.

Description	HPL	BASIC
<p>Send the Remote Message (by setting Remote Enable, REN, true and addressing the Measuring Receiver to Listen).</p> <p>Check that the Measuring Receiver's REMOTE and LISTEN annunciators are on.</p>	<p>rem 714</p>	<p>REMOTE 714</p>
<p>Send the Local Message to the Measuring Receiver</p> <p>Check that the Measuring Receiver's REMOTE annunciator is off but its LISTEN annunciator is on.</p>	<p>lcl 714</p>	<p>LOCAL 714</p>
<p>Send the Remote message to the Measuring Receiver.</p> <p>Check that the Measuring Receiver's REMOTE and LISTEN annunciators are on. Press the LOCAL key on the Measuring Receiver. Check that the Measuring Receiver's REMOTE annunciator is now off, but that its LISTEN annunciator remains on.</p>	<p>rem 714</p>	<p>REMOTE 714</p>

Sending the Data Message Check (Data Output)

This check determines whether or not the Measuring Receiver properly issues Data messages when addressed to talk. This check assumes that the Measuring Receiver is able to handshake and recognize its own address. Before beginning this check, select 40.0 SPCL.

Description	HPL	BASIC
Address the Measuring Receiver to talk and store its output data in variable V. (The output is Error 96 since there is no signal at its INPUT.)	red 714,V	ENTER 714;V
Display the value of V.	dsp V	PRINT V
Check that the Measuring Receiver's TALK annunciator is on. The controller's display should read 90000096000.00 (HP 9825A) or 90000096000 (HP 9835A and 9845A).		

Receiving the Data Message Check (Data Input)

This check determines whether or not the Measuring Receiver properly receives Data messages. The Data messages sent also cause the 7 least-significant HP-IB data lines to be placed in both their true and false states. This check assumes the Measuring Receiver is able to handshake, recognize its own address, and properly make the remote/local transitions. Before beginning this check, select 40.0 SPCL.

Description	HPL	BASIC
Send the first part of the Remote message (enabling the Measuring Receiver to remote).	rem 7	REMOTE 7
Address the Measuring Receiver to listen (complete the Remote message), then send a Data message (manually tuning the Measuring Receiver to 1 MHz.	wrt 714,"1MZ"	OUTPUT 714;"1MZ"
Check that the Measuring Receiver's REMOTE and LISTEN annunciators are on. Check also that its 15 kHz LP FILTER key light is on and the AUTO TUNING light is off.		

Local Lockout and Clear Lockout/Set Local Messages Check

This check determines whether or not the Measuring Receiver properly receives the Local Lockout message, disabling all front-panel keys. The check also determines whether or not the Clear Lockout/Set Local message is properly received and executed by the Measuring Receiver. This check assumes that the Measuring Receiver is able to handshake, recognize its own address, and properly make the remote/local transitions. Before beginning this check, select 40.0 SPCL.

Description	HPL	BASIC
Send the first part of the Remote message (enabling the Measuring Receiver to remote).	rem 7	REMOTE 7
Send the Local Lockout message	llo 7	LOCAL LOCKOUT 7
Address the Measuring Receiver to listen (completing the Remote message).	wrt 714	OUTPUT 714
Check that the Measuring Receiver's REMOTE and LISTEN annunciators are on. Press the Measuring Receiver's LOCAL key. Both its REMOTE and LISTEN annunciators remain on.		
Send the Clear Lockout/Set Local message.	lcl 7	LOCAL 7
Check that the Measuring Receiver's REMOTE annunciator is off but its LISTEN annunciator remains on.		

Clear Message Check

This check determines whether or not the Measuring Receiver properly responds to the Clear message. This check assumes that the Measuring Receiver is able to handshake, recognize its own address, make the remote/local changes, and receive Data messages. Before beginning this check, select 40.0 SPCL.

Description	HPL	BASIC
Send the first part of the Remote message (enabling the Measuring Receiver to remote).	rem 7	REMOTE 7
Address the Measuring Receiver to listen (completing the Remote message). Then send a Data message that sets the Measuring Receiver's tuning to manual.	wrt 714,"MZ"	OUTPUT 714;"MZ"
Check that the Measuring Receiver's REMOTE and LISTEN annunciators are on and that the AUTO TUNING light is off.		
Send the Clear message (setting the Measuring Receiver's tune mode back to automatic).	clr 714	RESET 714 For Series 200: CLEAR 714
Check that the Measuring Receiver's REMOTE and LISTEN annunciators are on and that the AUTO TUNING light is on.		

Abort Message Check

This check determines whether or not the Measuring Receiver becomes unaddressed when it receives the Abort message. This check assumes that the Measuring Receiver is able to handshake, recognize its own address, make the remote/local changes, and enter serial-poll mode. Before beginning this check, select 40.0 SPCL.

Description	HPL	BASIC
Send the Remote message to the Measuring Receiver.	rem 714	REMOTE 714 For Series 200: REMOTE 7 REMOTE 714
Check that the Measuring Receiver's REMOTE and LISTEN annunciators are on.		
Send the Abort message, unaddressing the Measuring Receiver.	cli 7	ABORTIO 7 For Series 200: ABORT 7
Check that the Measuring Receiver's LISTEN annunciator is off. Note that the HP 9835A and 9845A ABORTIO statement sends both the Abort message and the Local message. Thus, if the HP 9825A is being used, the Measuring Receiver's REMOTE annunciator should remain on. If the HP 9835A or 9845A is being used, the Measuring Receiver's REMOTE annunciator should turn off.		
Send the Local message (HP 9825A) only.	lcl 7	(The local message was already sent with the ABORTIO 7 statement above.)
Address the Measuring Receiver to talk and then store its output data in variable V.	red 714,V	ENTER 714;V
Check that the Measuring Receiver's LISTEN annunciator is off but that its TALK annunciator is on.		
Send the Abort message unaddressing the Measuring Receiver to talk.	cli 7	ABORTIO 7 For Series 200: ABORT 7

Abort Message Check (cont'd)

Description	HPL	BASIC
<p>Check that all the Measuring Receiver's HP-IB annunciators are off.</p> <p>Send the serial-poll-enable bus command (SPE) to place the Measuring Receiver in serial-poll mode.</p> <p>On the Measuring Receiver, key in 61.3 and then press the SPCL key. The display should show 1.0. This indicates the Measuring Receiver is in serial-poll mode (indicated by the "1").</p>	<p>wti 0,7;wti 6,24</p>	<p>SENBUS 714;1,24 For Series 200: SEND 7;CMD"?5X" &CHR\$(24)</p>
<p>Send the Abort message, removing the Measuring Receiver from serial-poll mode.</p> <p>Check that the Measuring Receiver's display shows 0.0. This indicates the Measuring Receiver properly left serial-poll mode upon receiving the Abort message.</p>	<p>cli 7</p>	<p>ABORTIO 7 For Series 200: ABORT 7</p>

Status Byte Message Check

This check determines whether or not the Measuring Receiver sends the Status Byte message in both the local and remote modes. This check assumes that the Measuring Receiver is able to handshake, recognize its own address, and make the remote/local changes. Before beginning this check, select 40.0 SPCL.

Description	HPL	BASIC
Place the Measuring Receiver in serial-poll mode and address it to talk (causing it to send the Status Byte message).	rds (714) → V	STATUS 714;V For Series 200: V =SPOLL(714)
Display the value of V.	dsp V	PRINT V
Depending on the vintage of the HP-IB interface (HP 98034A) used, the Measuring Receiver's TALK annunciator may be either on or off. The controller's display should read 0.00 (HP 9825A) or 0 (HP 9835A and HP 9845A).		
Send the Remote message	rem 714	REMOTE 714
Place the Measuring Receiver in serial-poll mode and address it to talk (causing it to send the Status Byte message).	rds (714) → V	STATUS 714;V For Series 200: V =SPOLL(714)
Display the value of V.	dsp V	PRINT V
Check that the Measuring Receiver's REMOTE annunciator is on. Depending upon the vintage of the HP-IB interface (HP 98034A) used, the Measuring Receiver's TALK annunciator may be either on or off. The controller's display should read 0.00 (HP 9825A) or 0 (HP 9835A and HP 9845A).		

Service Request Message Check

This check determines whether or not the Measuring Receiver can issue the Service Request message (set the SRQ bus control line true). This check assumes that the Measuring Receiver is able to handshake, recognize its own address, make the remote/local changes, and receive Data messages. Before beginning this check, select 40.0 SPCL.

Description	HPL	BASIC
Send the first part of the Remote message (enabling the Measuring Receiver to remote).	rem 7	REMOTE 7
Address the Measuring Receiver to listen (completing the Remote message) then send a Data message (enabling a Service Request to sent upon Instrument Error).	wrt714,"22.4SP"	OUTPUT 714;"22.4SP"
Make the controller wait 2 seconds to allow time for the Measuring Receiver message. (This step is not necessary if sufficient time is allowed.)	wait 2000	WAIT 2000
Read the binary status of the controller's HP-IB interface and store the data in variable V (in this step,7 is the interface's select code).	rds(7) → V	STATUS 7;V For Series 200: STATUS 7,7;V
Display the value of the SRQ bit.	dsp"SRQ =",bit (7,V)	PRINT "SRQ =";BIT (V,7) For Series 200: PRINT "SRQ =";BIT(V,10)
Check that the Measuring Receiver's REMOTE, LISTEN, and SRQ annunciators are on and that the controller's display reads an SRQ value of 1, indicating the Measuring Receiver issued the Require Service message.		

Trigger Message and Clear Key Triggering Check

This check determines whether or not the Measuring Receiver responds to the Trigger message and whether the CLEAR key serves as a manual trigger in remote. This check assumes that the Measuring Receiver is able to handshake, recognize its own address, make the remote/local changes, and send and receive Data messages. Before beginning this check, select 40.0 SPCL.

Description	HPL	BASIC
Send the first part of the Remote message (enabling the Measuring Receiver to remote).	rem 7	REMOTE 7
Address the Measuring Receiver to listen (completing the Remote message), then send a Data message (placing the Measuring Receiver in Hold mode).	wrt 714,"T1"	OUTPUT 714;"T1"
Send the Trigger message.	trg 7	TRIGGER 7
Address the Measuring Receiver to talk and store the data in variable V.	red 714,V	ENTER 714;V
Display the value of V.	dsp V	PRINT V
Check that both the Measuring Receiver's REMOTE and TALK annunciators are on. The controller's display should read 90000096000.00 (HP 9825A) or 90000096000 (HP 9835A and HP 9845A) or 9.00000 96E+10 (HP Series 200).		
Address the Measuring Receiver to talk and store the data in variable V.	red 714,V	ENTER 714;V
Check that the controller's "run" indicator is still on indicating that it has not received data from the Measuring Receiver. Press the Measuring Receiver's CLEAR key. The controller's "run" indicator should turn off.		

3-14. DETAILED OPERATING INSTRUCTIONS

Introduction to the Section

These Detailed Operating Instructions provide a complete operating reference for the Measuring Receiver user. As an operating reference, this section contains all relevant information regarding operating the Measuring Receiver. (If you intend to operate the Measuring Receiver remotely, the *Remote* section contains information about how the Measuring Receiver interacts with a controller.)

This section is intended to be a reference document for users who have already learned how to make basic measurements using the *HP 8902A Basic Operation and Application Guide* (part number 08902-90049) included with this documentation package. For your application, the Basic Operation and Application Guide may be all you need to make measurements. However, the Detailed Operating Instructions will enable you to use the full capabilities of the Measuring Receiver.

Section Organization

The section is organized into tabbed sections oriented toward specific measurement types. Each tabbed section contains all measurement capabilities and support functions involved in making that measurement type.

For example, the tabbed section, *Modulation*, contains all information about specific AM, FM, and Φ M measurements as well as:

- selecting an audio detector,
- selecting an audio filter,
- selecting an audio range,
- using the Modulation Output, and
- accounting for residual noise effects.

How To Find Information About a Specific Measurement

Behind most tabs is a table of contents for that tabbed section. Use this table of contents to find the Detailed Operating Instruction relevant to the measurement you are trying to make.

For example, if looking for information about making an FM measurement, find the tab "Modulation". Find the table of contents behind that tab. Then look up the Detailed Operating Instruction, *FM*. Turn to the page listed for that instruction. Within that Detailed Operating Instruction, you will find the following categories of information:

Functions lists all the Measuring Receiver functions to be discussed that pertain to FM.

Description introduces the FM measurement and any of the listed Functions.

Procedure provides specific instructions about making the FM measurement.

HP-IB lists all the Hewlett-Packard Interface Bus (HP-IB) codes relevant to making the FM measurement in remote operation.

Measurement Technique describes the basic circuitry used to make the measurement. Sometimes, this information can provide an experienced user with a basis for adapting the Measuring Receiver to varied measurement situations.

Comments provide miscellaneous information that is not essential to the basic measurement but could be valuable to an experienced user attempting to use the Measuring Receiver in measurement situations not explicitly described in the "Procedure".

RF Power and Level Contents

BROADBAND RF POWER

RF Power.....	3-75
<ul style="list-style-type: none"> • How to measure broadband RF power. • How to calibrate an RF power sensor (zero, calibrate, and save calibration) using the 1 mW reference. • How to enter the power sensor's calibration factors into the instrument. 	
RF Power Calibration Factor Entry (HP-IB).....	3-85
<ul style="list-style-type: none"> • How to enter the power sensor's calibration factors into the instrument using a program list in BASIC (for the the HP Series 200 computers.) 	
RF Level.....	3-89
<ul style="list-style-type: none"> • How to measure (uncalibrated) broadband RF power measurement without an RF power sensor. 	
Recorder Output.....	3-91
<ul style="list-style-type: none"> • How to use the rear-panel RECORDER OUTPUT to monitor measurements via a dc voltmeter. • How to use the rear-panel RECORDER OUTPUT to improve the accuracy of RF power measurements. 	

TUNED RF LEVEL

Tuned RF Level.....	3-95
<ul style="list-style-type: none"> • How to make low-level, tuned RF power measurements. • How to select the IF detector (synchronous or average). • How to select the optimum IF detector averaging time. • How to make Tuned RF Level measurements with Option 050. • How to calibrate the tuned RF level measurement when prompted by the UNCAL and RECAL annunciators). 	
IF Level.....	3-109
<ul style="list-style-type: none"> • How to measure the relative ALC level of AM demodulator. 	
Peak Tuned RF Level.....	3-113
<ul style="list-style-type: none"> • How to measure (uncalibrated) peak, tuned RF power. 	
Attenuator Measurements.....	3-115
<ul style="list-style-type: none"> • How to make relative, tuned RF level measurements. 	
Selective Power Measurements (Option Series 030).....	3-119
<ul style="list-style-type: none"> • How to make selective, off-channel power or noise measurements (Option Series 030). 	
IF Output.....	3-129
<ul style="list-style-type: none"> • How to use the rear-panel IF OUTPUT to obtain the 455 kHz or 1.5 MHz IF signal. 	

GENERAL LEVEL MEASUREMENT FUNCTIONS

External Attenuation.....	3-131
<ul style="list-style-type: none"> • How to obtain a direct reading of the RF level into an externally connected input attenuator. 	
Remote Control RF Switch.....	3-133
<ul style="list-style-type: none"> • How to use the rear-panel REMOTE CONTROL connectors to control a remote RF switch similar to the way the RF switch is controlled in the HP 11722A Sensor Module. 	

RF Power

FUNCTIONS

RF POWER, % CAL FACTOR, ZERO, CALIBRATE, SAVE CAL, DISPLAY FREQ, Special Function 37 (Calibration Factors:RF Power)

DESCRIPTION

The Measuring Receiver can make calibrated measurements of RF and microwave power levels when used with a power sensor or sensor module.¹ (Refer to Table 1-1, *Specifications* for a list of compatible power sensors. Note that the Measuring Receiver automatically determines the type and sensitivity of the sensor.) Absolute level accuracy and sensitivity are determined by the particular power sensor selected and the SWR of the signal source.

Calibration. Specified measurement accuracy is ensured if calibration is performed with each power sensor. Calibration consists of four steps:

1. Entering the 1 mW, 50 MHz reference calibration factor and the frequency-dependent calibration factors from the power sensor's calibration label.

Calibration factors (cal factors) are used to compensate the external power sensor's frequency response relative to a 1 mW reference calibration made at 50 MHz using the Power Reference Oscillator. The cal factors, including a reference cal factor, are usually printed on the power sensor or sensor module.

Cal factors can be entered and stored in an internal table (Automatic Cal Factors) in the instrument's non-volatile memory. The table is automatically accessed during RF power measurements (after the Measuring Receiver has tuned to the frequency) to correct for the non-linear frequency response of the power sensor. If no entry in the table directly corresponds to the frequency being measured, the Measuring Receiver derives a cal factor through linear interpolation using the nearest calibration points in the table (on either side of the frequency being measured). Up to sixteen frequency/calibration-factor pairs can be entered (plus the reference cal factor).

You can enter, review, and manually alter cal factors. Also, you can manually override the selection of automatic cal factors without altering the table.

2. Zeroing the power sensor.

The zeroing process cancels any inherent dc offset that may be present within the power sensor under zero power condition.

3. Configuring the Measuring Receiver to measure the power from the 1 mW RF power reference (the 1 mW Power Reference Oscillator).

The internal 1 mW Power Reference Oscillator, used in RF power calibration is an extremely amplitude-stable RF power source that has been set to 1 mW (0 dBm) into 50 Ω , traceable to the National Bureau of Standards (NBS). This power reference enables the Measuring Receiver to precisely determine the sensitivity of the external power sensor at 50 MHz (voltage out vs. power in).

4. Scaling subsequent power measurements to the 1 mW calibration.

In scaling, the Measuring Receiver equates the output from the power meter to 1 mW.

A sensor module contains a power sensor path and a through path for RF measurements as well as an RF switch to switch between the two paths. The Measuring Receiver controls the switching of the input signal depending on the measurement selected.

PROCEDURE

Determine Cal Factor Status. Determine the status of the calibration factors and enter new calibration factors if necessary. Connect the power sensor or sensor module to the Measuring Receiver's SENSOR input. (The power sensor cable need not be connected to the source at this time.)

1. Select RF POWER. If Error 15 is displayed, no calibration factors have been entered. Enter calibration factors as described in steps a and b below. If Error 15 is not displayed, proceed to step 4.
2. Enter the reference cal factor (the reference cal factor is the cal factor for 50 MHz; all other cal factors are relative to it):
 37.3 SPCL, reference cal factor value (printed on a label on the power sensor),
 % CAL FACTOR (Blue Key, MHz).
 Example: Enter a reference cal factor of 98.5% into the Automatic Cal Factor table.

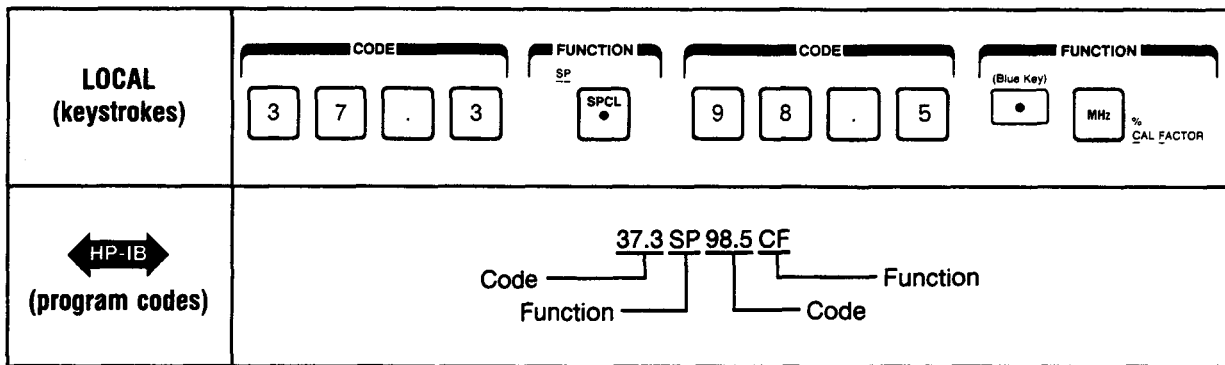

3. Enter each frequency/cal-factor pair:
 37.3 SPCL, frequency value (in MHz), cal-factor value, %CAL FACTOR (Blue Key, MHz).
 Repeat this step until all frequency/cal-factor pairs have been entered.
 - Disregard Error 15 if it is displayed during cal factor entry.
 - If an error is made during entry of any value, select CLEAR and immediately re-enter the correct value.
 Example: Enter a cal factor of 99.0% at a frequency of 1 MHz.

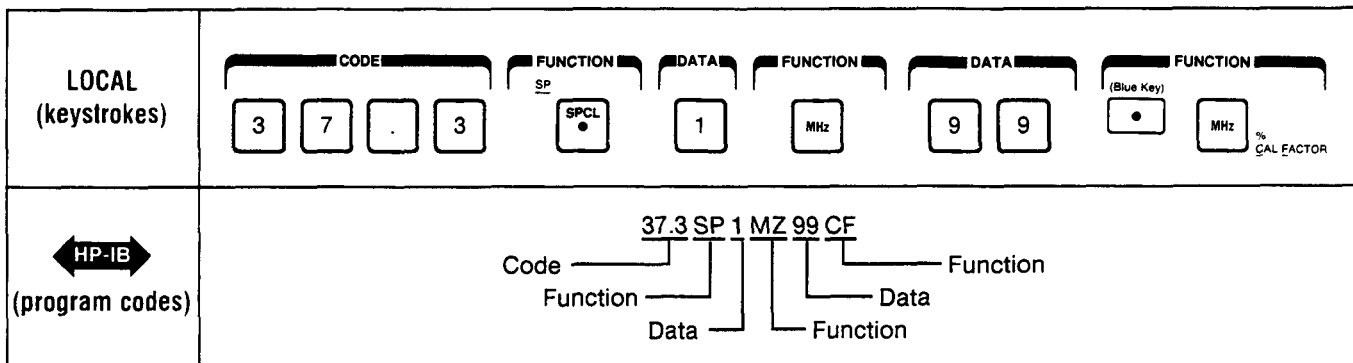

4. Verify that the Automatic Cal-Factor table was entered correctly.
Recall the reference cal factor and compare the value to that on the label on the power sensor:
37.5 SPCL, % CAL FACTOR (Blue Key, MHz)
5. Recall each frequency/cal-factor pair and compare each value to its counterpart on the power sensor:
37.6 SPCL;
DISPLAY FREQ (Blue Key, \uparrow) to display the frequency value,
% CAL FACTOR (Blue Key, MHz) to display the cal factor value.
Repeat this step until all frequency/cal-factor pairs have been verified.
 - Attempting to read beyond the end of the table results in Error 26.
 - To replace an existing cal-factor entry, enter the new cal factor at the frequency previously used in the entry (refer to step 1).
 - To remove an existing cal factor from the table in memory, enter 0% as the cal factor at the frequency previously used in the entry (refer to step 1).
6. To re-enter the Automatic Cal Factor mode, select AUTOMATIC OPERATION, then reselect RF POWER.

Zero the Sensor. If the instrument has just been turned on, allow at least a half-hour continuous operation. Connect the sensor between the Measuring Receiver's SENSOR input and CALIBRATION RF POWER OUTPUT.

7. Select ZERO. If a power sensor is being used (rather than a sensor module) the CALIBRATE key light must be off for proper zeroing. (A sensor module has an internal switch that will automatically switch out any input signal.) After a few seconds, 0.0 00 W is displayed, then a measurement result of near zero power is displayed.

Configure the 1 mW RF Power Reference

8. Select CALIBRATE. The instrument displays the power from the RF power reference using the last calibration scaling.

Enable Calibration Scaling

9. Select SAVE CAL (Blue Key, CALIBRATE). Read 1.000 mW. The calibration scaling stays in effect until another SAVE CAL operation is done. Select CALIBRATE again to turn off the calibrator (CALIBRATE key light off). (If the calibrator is not turned off, the RF power measurements will not range properly.)

THE MEASURING RECEIVER IS NOW CALIBRATED.

Measure power levels by selecting RF POWER.

(Note that when calibrating the Measuring Receiver over HP-IB, use T3 settling time code between the CALIBRATE (C1) and SAVE CAL (SC) codes. For example: C1T3SC.)

Additional Recommendations:

- Re-calibrate the sensor when ambient conditions change or approximately every eight hours.
- Whenever the source frequency is changed, either select the new frequency manually (in MHz) or select FREQ to let the instrument automatically tune to the signal, then re-enter the RF Power measurement mode. Also, if the tuned frequency moves more than ± 5 kHz from the frequency at which the power sensor reference was taken, the instrument must be retuned.
- Use the table on the following page, "Summary of Special Function 37" for a quick overview of all the codes that manipulate the RF power cal factors.

Summary of Special Function 37

SPCL	Special Function Description	Comments
37.0	Selects the Automatic Cal Factor mode. This enables the Measuring Receiver to automatically select cal factors based on those entered using Special Function 37.3.	<ul style="list-style-type: none"> • This mode is selected upon instrument power-up and with Automatic Operation. • Can be keyed from any Measurement mode.
37.1	Selects the Manual Cal Factor Mode. This enables the user to override the automatic selection of cal factors. Procedure: To enter a manual cal factor, select: 37.1 SPCL, cal factor value, % CAL FACTOR (Blue Key, MHz)	<ul style="list-style-type: none"> • If no cal factor is entered, the Measuring Receiver uses the cal factor recalled last from the table as the manual entry. • The manual cal factor remains in effect when the Measuring Receiver is returned. • The automatic cal factor table is not affected by any manual cal factor entries. • Can be keyed only after selecting RF POWER.
37.2	Displays the status of the cal factor mode (0 = Automatic, 1 = Manual).	<ul style="list-style-type: none"> • Can be keyed from any Measurement mode.
37.3	Prepares to enter a reference cal factor or a frequency/cal-factor pair into the appropriate table in memory. Procedures: To enter the reference cal factor, select: 37.3 SPCL, cal factor value, % CAL FACTOR (Blue Key, MHz). To enter each frequency/cal-factor pair, select: 37.3 SPCL, frequency value (in MHz), MHz key, cal factor value, % CAL FACTOR (Blue Key, MHz). (It's unnecessary to wait until the values are displayed before continuing with subsequent entries.) (See examples in this section.)	<ul style="list-style-type: none"> • If an error is made during entry of any value, select CLEAR and immediately re-enter the correct value. • To replace an existing cal factor entry, enter the new cal factor at the frequency previously used in the entry. The Measuring Receiver will automatically save the entry in the correct order in the table. • To remove an existing cal factor from the table in memory, enter 0% as the cal factor at the frequency previously used in the entry. • Can be keyed from any Measurement mode.
37.4	Displays the number of entries in the table.	<ul style="list-style-type: none"> • The number of table entries displayed also includes the reference calibration factor. • Can be keyed from any Measurement mode.
37.5	Prepares to recall the reference cal factor from the table. Procedure: To display the reference cal factor, select: 37.5 SPCL, % CAL FACTOR (Blue Key, MHz).	<ul style="list-style-type: none"> • This special function configures the Measuring Receiver to use manual cal factors with the reference cal factor from the table as the manual entry. To re-enter the Automatic Cal Factor mode, select AUTOMATIC OPERATION or 37.0 SPCL. • Can be keyed only after selecting RF POWER.
37.6	Prepares to recall the next frequency/cal-factor pair from the table. Procedure: To display the frequency, select: 37.6 SPCL, DISPLAY FREQ (Blue Key, kHz). To display the cal factor, select: % CAL FACTOR (Blue Key, MHz). 37.6 SPCL sequentially accesses frequency/cal-factor pairs. (See example in this section.)	<ul style="list-style-type: none"> • The table in memory is accessed sequentially (the lowest frequency accessed first). To access the lowest frequency in the table, select 37.5 SPCL before selecting 37.6 SPCL. • This special function configures the Measuring Receiver to use manual cal factors with the cal factor recalled last from the table as the manual entry. To re-enter the Automatic Cal Factor mode, select AUTOMATIC OPERATION, then reselect RF POWER. • An attempt to read beyond the end of the table results in Error 26.
37.9	Clears the table of cal factors from memory. To enter a manual cal factor, use 37.1 SPCL. To enter a new table of calibration factors, use 37.3 SPCL.	<ul style="list-style-type: none"> • Displays Error 15 if automatic cal factors were being used. • Can be keyed from any Measurement mode.

HP-IB PROGRAM CODES

% CAL FACTOR = CF
 CALIBRATE on = C1
 CALIBRATE off = C0
 DISPLAY FREQ = FR

Hz = HZ
 LIN results = LN
 LOG results = LG
 MHz = MZ

RF POWER = M4
 SAVE CAL = SC
 WATTS Units = WT
 ZERO = ZR

MEASUREMENT TECHNIQUE

The RF Power Measurement

The power sensor produces a small dc voltage which is proportional to the power dissipated in the sensor's input load. The dc voltage is then converted to ac, amplified, and converted back to dc. The Measuring Receiver's internal dc voltmeter measures the voltage and displays the reading in terms of power.

Five ranges of amplification are used to encompass the power sensor's wide dynamic range. Special Function 10 permits manual selection of the five ranges: Range 1 (10.1 SPCL) has the most amplification (the most sensitivity), while Range 5 (10.5 SPCL) has the least amplification (the least sensitivity). The ranges are not specified in terms of absolute power because the sensor type determines the sensitivity.

The chopper in the power sensor converts the dc voltage (generated by the power sensing element) to a 220 Hz, chopped, ac signal. The ac signal is then amplified and rectified by a synchronous detector whose configuration alternates between a non-inverting and an inverting amplifier in step with the chopper. (The 220 Hz Multivibrator is the source for both chopping signals.) The result is a rechopped, dc level proportional to the dc output of the RF power sensing element of the power sensor. This chopping and rechopping method reduces the power meter's susceptibility to dc drift and noise.

The dc level from the Synchronous Detector is filtered, to reduce noise then measured by the Voltmeter. On the more sensitive ranges, filtering is increased to smooth out the large noise component on the signal and thus stabilize the displayed reading.

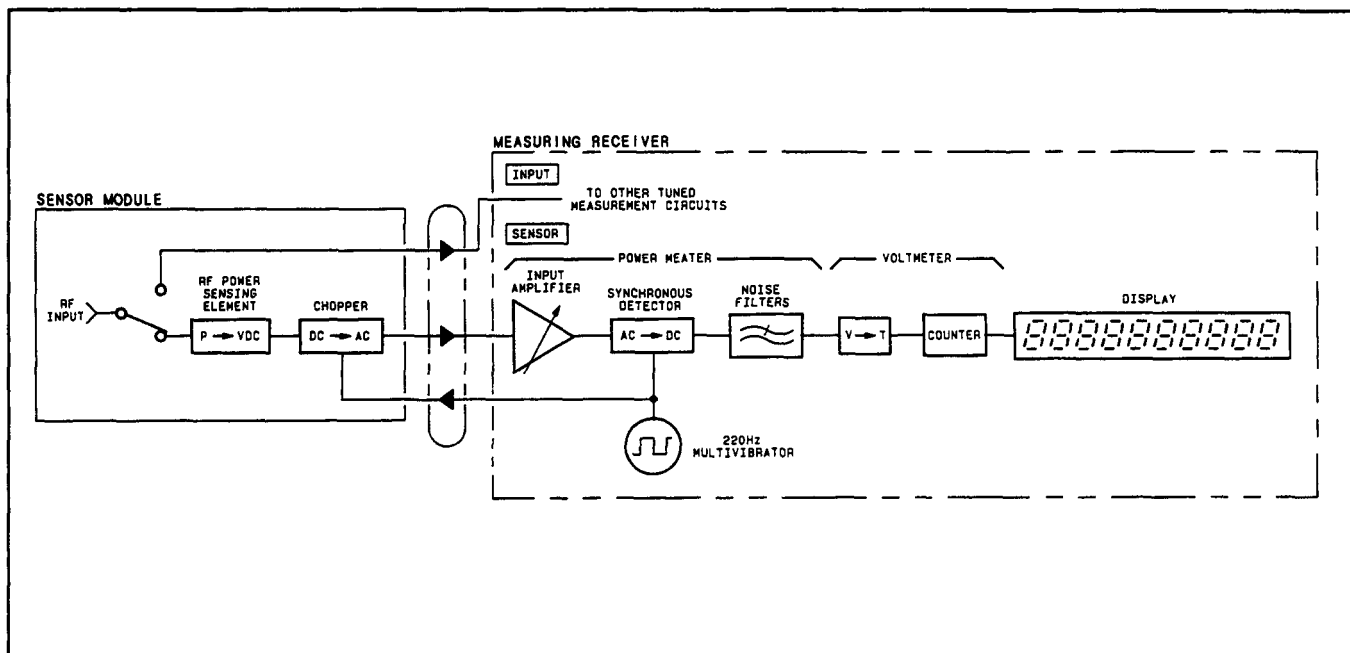

RF Power Block Diagram

RF Power Calibration

With the external power sensor properly connected to the Measuring Receiver, and the sensor's RF input connected to the CALIBRATION RF POWER OUTPUT, calibration begins by first determining the sensor type. (See the Simplified Block Diagram of RF Power Calibration.) A switch at the input of the Voltmeter connects the power sensor's resistor to the Voltmeter. The voltage across the resistor indicates, to the Measuring Receiver, the type of power sensor being used. UNCAL and RECAL annunciators are displayed if the sensor type differs from that used in a previous calibration.

When the ZERO key is pressed, the internal controller sends out a signal to the sensor module to switch out the RF input to the power sensor and directs the power meter to make a power measurement. (The Measuring Receiver assumes that 0W is at the power sensor input. If the Calibrate function is on, the 1 mW RF Power Reference stays on. If power sensor with no RF switch is connected to the calibrator output, the instrument will not zero properly.) The controller uses the zeroing digital-to-analog converter (DAC) in the power meter to output a dc voltage to cancel any dc offset that may be present at the power sensor. The zeroing process persists until the reading is zero, which may take several seconds to complete.

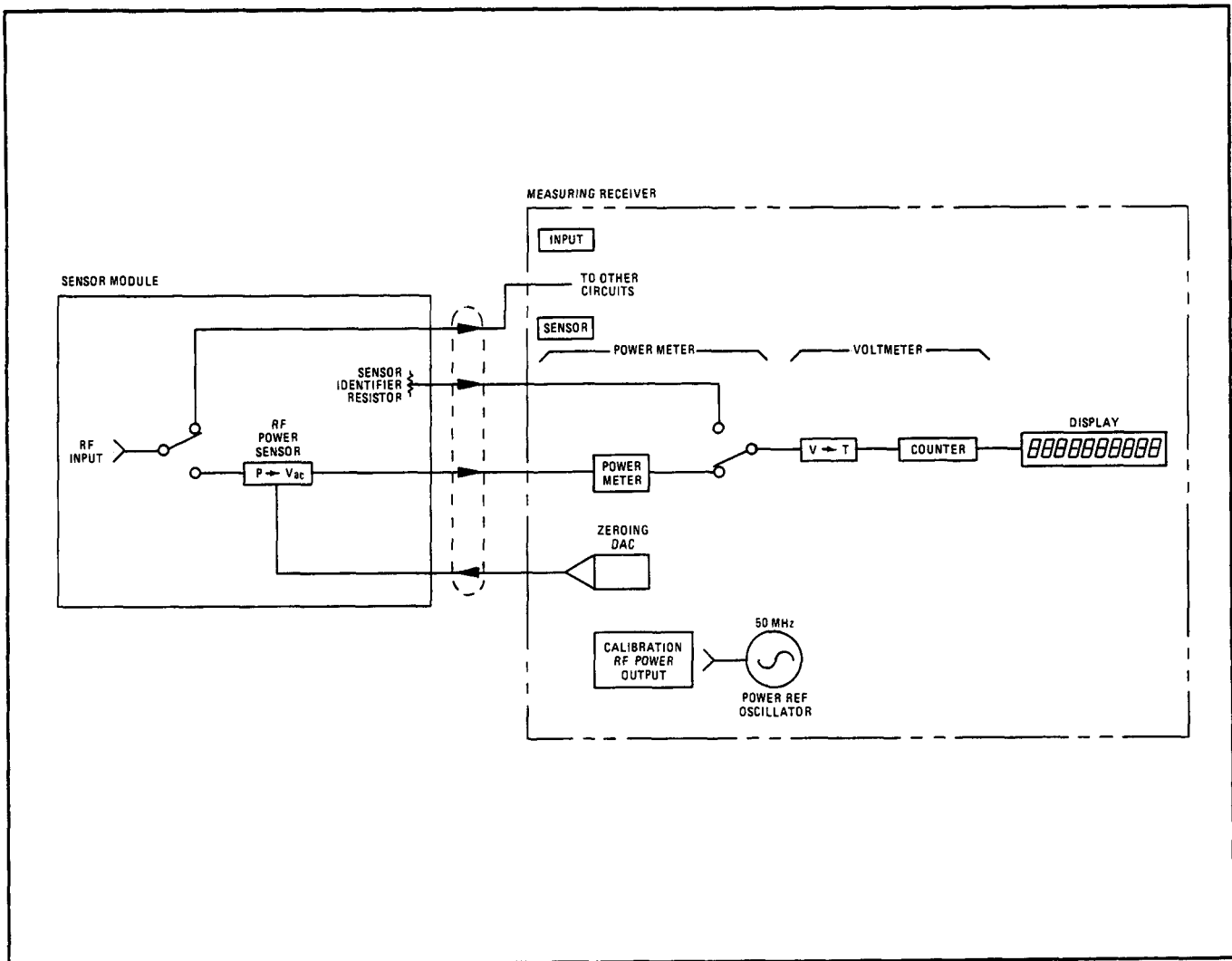

Simplified Block Diagram of RF Power Calibration

When CALIBRATE is selected, the power reference oscillator outputs a calibrated, 1 mW signal at 50 MHz. When SAVE CAL is selected, the controller equates the output from the power meter to 1 mW.

The calibration procedure allows the instrument to set the power-measurement transfer function so the displayed power correctly represents the actual power. This procedure can be visualized as a process that adjusts the intercept and slope of the sensor's transfer function. The ZERO key sets the zero crossing (intercept), and the SAVE CAL key sets the gain (slope). (See the following figure.) The displayed power is given by the equation:

$$P_{dis} = mP_{act} + b$$

where;

- P_{dis} is the Displayed Power,
- P_{act} is the Actual Power,
- b is the zero crossing, and
- m is the slope.

The calibration routine forces $b = 0$ and $m = 1$.

The following example shows the different responses that occur during calibration:

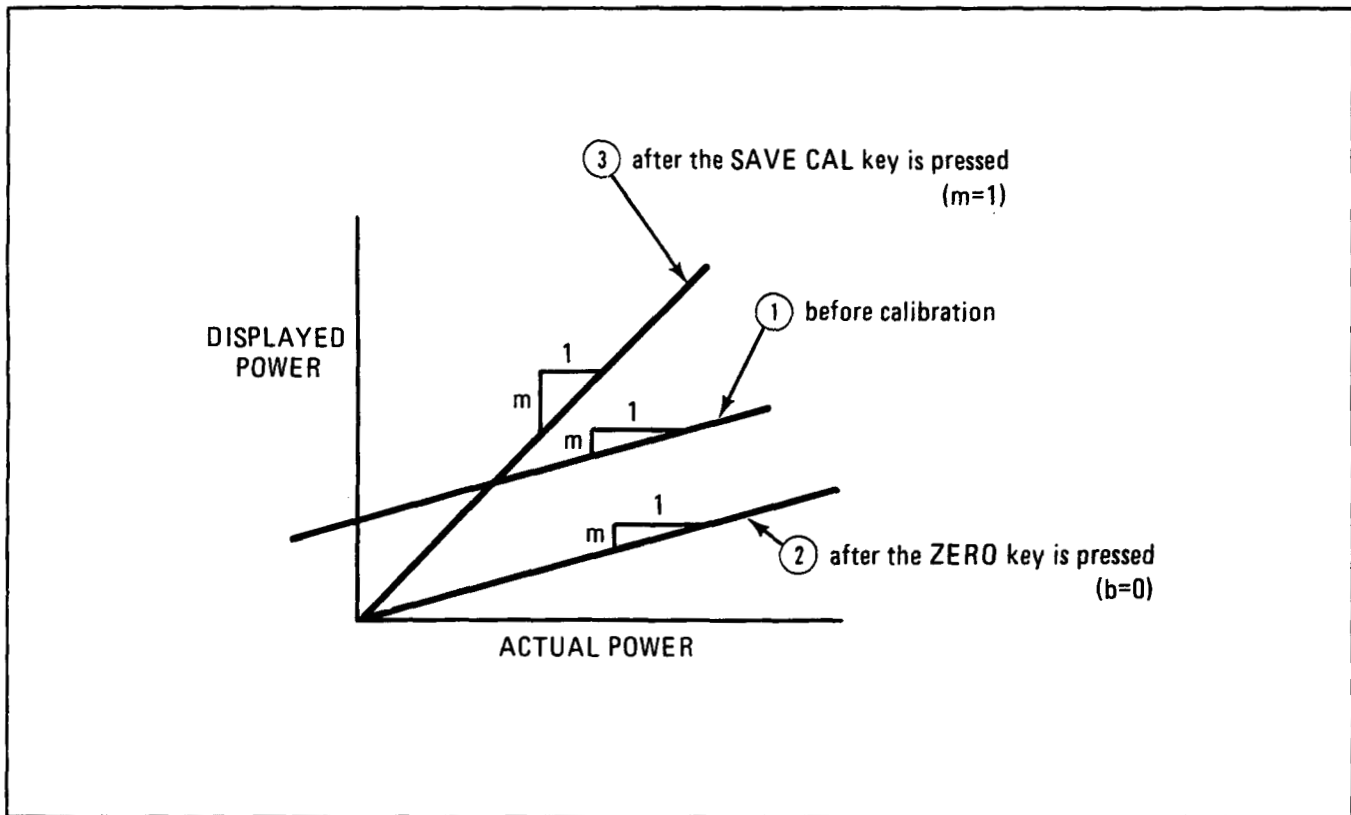

Minor adjustments in the slope are made by the controller, based on the calibration factors, to correct for variations in the power sensor's sensitivity due to frequency and mismatch.

COMMENTS

Reasons to Recalibrate.

Any time the power-sensor type is changed (for example, from an HP 8482A to an HP 8484A), and RF POWER is selected, the Measuring Receiver displays the need for recalibration by lighting the RECAL annunciator.

Any time power sensors of the same type are exchanged (for example, from one HP 11722A to another), and RF POWER is selected, the Measuring Receiver DOES NOT recognize the need for recalibration. When in doubt about whether the calibration factors match the power sensor, use Special Function 37 to display the calibration factors as described in *Procedure step #4* in this operating instruction.

Calibration information is retained in the Measuring Receiver's non-volatile memory even when the Measuring Receiver is disconnected from its power source.

Finer Resolution for dB Measurements ²

Special Function 32.1 enables a resolution of 0.001 dB. For audio frequency measurements, this special function enables a resolution of 0.1 Hz for frequencies from 100 to 250 kHz instead of the normally displayed resolution of 1 Hz. The selection of Special Function 32.0 or 32.1 is maintained through instrument power down.

32.0 Power is displayed with the normal measurement resolution of 0.01 dB.

32.1 Power is displayed with a measurement resolution of 0.001 dB.

32.2 Displays 0 if the normal measurement resolution is enabled (32.0 SPCL) and displays 1 if a finer resolution is enabled (32.1).

Error 15.

Error 15 is displayed until all necessary cal factor entries are made. Two calibration factors must be available for the Measuring Receiver to make RF power measurements; a reference calibration factor, and a calibration factor at the signal frequency (entered manually or derived automatically from the Automatic Calibration Factor table). Also, if RF power measurements are attempted at frequencies higher or lower than any frequency in the table, interpolation is not possible and Error 15 is displayed.

Specifications for Cal-Factor Entry

RF Frequency Range:	0-42 GHz RF Frequency
Resolution:	50 kHz
Calibration Factor Range:	40-120%
Calibration Factor Resolution:	0.1%
Maximum number of entries/table:	17 for first table, 23 for second table

² This special function is not available with firmware date codes 234.1985 and below. (To display the firmware date code, select 42.0 SPCL.) To order a ROM set that contains this special function, contact the nearest HP sales office.

A Second Cal-Factor Table for High-Frequency Measurements.

A second table having up to 22 pairs of frequency/cal-factor pairs (plus a reference cal factor), is available for use with an external down-converter in the Frequency Offset mode. (Refer to *Frequency Offset Control* on page 3-255 for more information about this mode.)

When measuring power levels at high frequencies using a high-frequency power sensor or sensor module (such as the HP 11792A), enter the reference cal factor as an entry in the table at 50 MHz. If this frequency/cal factor pair is not entered, the instrument will not measure power at frequencies less than the lowest frequency entered in the cal factor table (2 GHz in the case of the HP 11792A).

Storing of Calibration Factor Tables.

The Store/Recall function cannot store a cal-factor table. However, to avoid re-entering tables when frequent interchanging of power sensors is necessary, either use Manual Calibration Factors, or use the second table for the second power sensor. Select 27.3 SPCL and use 0 Hz as the external, Local Oscillator (LO) value. (Refer to *Frequency Offset Control* on page 3-255 for a procedure on entering an external LO value.)

These two Automatic Calibration Factor tables are retained in the instrument's non-volatile memory for use in all subsequent RF power measurements. Every time you use the second table, you must enter the external LO value.

User-Built Sensor Module.

Any compatible power sensor can be configured as a sensor module using an external RF switch wired to the remote control connectors on the Measuring Receiver's rear panel. (Refer to *Remote Control RF Switch* on page 3-133.)

Calibration Factor Resolution.

Calibration factors have a resolution of 0.1%.

HP-IB: Interaction Between Calibration On and Zero.

C0 aborts ZR, but when ZR is timed out, C1 is not aborted.

HP-IB: Using Save Cal.

When calibrating the Measuring Receiver over HP-IB, use T3 settling time code between the Calibrate and Save Cal codes. For example:

```
C1T3SC
```

Input/Output Status.

MODULATION OUTPUT/AUDIO INPUT is disabled during RF power measurements.

Relative Measurements.

If RF power is to be displayed relative to a reference, enter the value as a ratio reference using the RATIO key. (Refer to *Ratio* on page 3-245.)

Frequency-Selective Level Measurements.

Use the Tuned RF Level function to make frequency-selective, absolute level measurements.

Source Impedance.

All measurement units assume a source impedance of 50Ω.

Power Measurements Alter Some Instrument States.

The instrument exits the automatic tuning mode when the RF Power function is selected. The RF, LO, and IF sections are inactive since power is being measured at the external sensor.

Reference Cal Factor Not Affected by Changing the Cal Factor Mode.

The SAVE CAL key, used in conjunction with RF Power Calibration, scales subsequent RF power measurements to the 1 mW RF Power Reference and saves the Scaling Factor in non-volatile memory. Changing the calibration factor mode does not change the reference calibration factor in use; for example, if the Measuring Receiver is calibrated from the manual cal factor mode and then the Automatic Cal Factor mode is selected, the instrument will continue to use the manually-entered reference calibration factor until another SAVE CAL operation is initiated from the Automatic Calibration Factor mode.

Manual Cal Factors

Manual Cal Factors are not frequency selective; that is, as frequency is changed, the instrument will continue to use the calibration factor entered last. To obtain accurate measurements when using Manual Cal Factors, a new calibration factor should be entered each time the frequency is changed.

The Manual Calibration Factor is not retained in the Measuring Receiver's non-volatile memory and therefore, must be re-entered after AUTOMATIC OPERATION or INSTR PRESET is selected.

RF Power Calibration Factor Entry Example Program

3-2. DESCRIPTION

The program list can be used to enter the RF power calibration factor (cal factor) table using an HP series 200 controller loaded with BASIC 3.0. (Cal factors are entered and stored in an internal table in the Measuring Receiver's non-volatile memory—refer to *RF Power*.) It might be useful to use this program to enter the cal factor table rather than entering the cal factors manually.

You may want to modify this program. For example, to increase the number of cal factors that can be entered into the table, change program lines 220, 300, and 500 to specify to 16 rather than to 10. When running this program, softkeys are set up with the following labels:

Address

Allows you to enter the HP-IB address of the Measuring Receiver.

Display Table

Displays the table of cal factors just entered. These are not necessarily the cal factors being used by the Measuring Receiver.

Enter Table

Enables you to enter individual cal factors into the cal factor table.

Read Cal

Displays the calibration factor table currently being used by the Measuring Receiver.

Send

Loads the calibration factor table into the Measuring Receiver that was entered with Enter Table.

3-3. PROCEDURE

Enter the program into an HP series 200 controller and connect the Measuring Receiver (via HP-IB) to the controller. Connect the power sensor or sensor module to the Measuring Receiver's SENSOR input. (The power sensor cable need not be connected to the source at this time.)

Follow the steps below to use the program. (Note that words that have brackets around them like this: **<RUN>**, are keys on the controller. Words in boxes like this: Address, are softkeys displayed on the controller's screen.)

1. Select **<Run>**.
2. Select softkey, Address and enter the three-digit code that comprises the controller's select code (for example, 7) and the Measuring Receiver's address (for example, 14). (Display the Measuring Receiver's address by selecting BUS ADRS—Blue Key, LOCAL—on the Measuring Receiver.) For these examples, you would type in:

7 1 4 **<ENTER>**

3. If you want to display the cal factors currently being used by the measuring receiver, go to step 7.

4. Enter the new frequency/cal factor pairs by selecting .

a. The controller will prompt:

"New Cal Factor for REF position cal factor?"

Enter the reference calibration factor. For example, enter 100% as:

1 0 0 <ENTER>

b. The controller will prompt:

"New Frequency for number '1' cal factor?"

Enter the frequency (in MHz) for the first frequency/cal factor pair. For example, enter 100 kHz as:

. 1 <ENTER>

c. The controller will prompt:

"New Cal Factor for number '1' frequency?"

Enter the cal factor for the first frequency/cal factor pair, for example, enter 99.0% as:

9 9 . 0 <ENTER>

d. Continue entering the nine other frequency/cal factor pairs until the table is complete.

Note that selecting **ENTER** as a response to a prompt without specifying a value will automatically select the value currently in the table.

5. Select to see the cal factors that you have entered.

6. Select to put those cal factors into the cal factor table in the Measuring Receiver.

7. To display the cal factors currently used by the Measuring Receiver, select . The controller will query the Measuring Receiver and then display a list of frequency/cal-factor pairs currently in the table. The cal factors are listed in the format:

50	98.9
.1	99.0
.3	97.2
1.0	99.8
3.0	99.5
10	98.7
30	99.3
100	97.9
300	98.1
1000	99.1
2600	99.7

The first column lists each frequency (in MHz) of the frequency/cal factor pair. The second column lists each cal factor (in %) of the frequency/cal factor pair. (The first frequency/cal factor pair listed is the reference cal factor that is measured at 50 MHz. This frequency cannot be changed.) To enter new frequency/cal factor pairs, go to step 4.

3-3. PROGRAM LISTING

```

10      COM /Cal_factor/ Freq(0:16),Cal(0:16),Hpib
20      DIM A$(40)
30 Relabel:CALL Clearscreen
40      PRINT
50      PRINT "Use the softkeys below to ENTER, READ, or SEND cal factors."
60      PRINT "-----"
70      ON KEY 5 LABEL "Address" GOTO Address
80      ON KEY 6 LABEL "Display Table" GOTO Print
90      ON KEY 7 LABEL "Enter Table" GOTO Enter
100     ON KEY 8 LABEL "Read Cal" GOTO Read
110     ON KEY 9 LABEL "Send" GOTO Send
120 Idle: DISP "Waiting for command . ."
130     GOTO Idle
140 Address:DISP "What is the 8901B/8902A HP-IB address";
150     LINPUT Hpib$
160     Hpib=VAL(Hpib$)
170     GOTO Relabel
180 Print: CALL Clearscreen
190     PRINT
200     PRINT " CAL FACTORS"
210     PRINT "-----"
220     FOR I=0 TO 10
230         PRINT Freq(I),Cal(I)      ! Print out cal factors.
240     NEXT I
250     GOTO Idle
260 Enter: OFF KEY
270     DISP "New Cal Factor for REF position cal factor";
280     INPUT Cal(0)
290     Freq(0)=50
300     FOR I=1 TO 10
310         DISP "New Frequency for number";I;" cal factor";
320         INPUT Freq(I)
330         DISP "New Cal Factor for number";I;" frequency";
340         INPUT Cal(I)
350     NEXT I
360     GOTO Relabel
370 Read:  CALL Clearscreen
380     OUTPUT Hpib;"41.SPM4TO"      ! Set to RF POWER mode.
390     OUTPUT Hpib;"37.4SP"        ! Ask how many cal factors there are.
400     ENTER Hpib;Pairs           ! Enter the number of cal factors.
410     OUTPUT Hpib;"37.5SP CF"    ! Ask for reference cal factor-50 MHz.
420     ENTER Hpib;Cal(0)         ! Enter reference cal factor.
430     Freq(0)=50                ! Ref cal is always 50 MHz.
440     FOR I=1 TO Pairs
450         OUTPUT Hpib;"37.6SP FR" ! Ask for next frequency.
460         ENTER Hpib;Frequency   ! Enter next frequency.
470         Freq(I)=Frequency/1.E+6 ! Divide by 1 million to get MHz.
480         OUTPUT Hpib;"CF"      ! Ask for next cal factor
490         ENTER Hpib;Cal(I)     ! Enter next cal factor.
500     NEXT I
510     GOTO Print
520 Send:  OUTPUT Hpib;"41.SPM4TO37.9SP" ! Clears the current cal factors.
530     IMAGE "37.3SP",4D.2D,"CF"

```

```
540     OUTPUT Hpib USING 530;Cal(0)  ! Send reference cal factor.
550     FOR I=1 TO 10
560         IMAGE "37.3SP",8D.2D,"MZ",4D.2D,"CF"
570         OUTPUT Hpib USING 560;Freq(I),Cal(I)  ! sending new cal factors.
580     NEXT I
590     BEEP
600     GOTO Relabel
610     END
620     !!
630     Clearscreen:SUB Clearscreen
640     !!
650         OUTPUT 1 USING "#,@"
660         DISP
670     SUBEND
```

RF Level

FUNCTIONS

Special Function 35 (RF Level)

DESCRIPTION

The RF Level function enables the Measuring Receiver to measure and display the peak, RF power. RF level measurements are initiated with Special Function 35 or with the RF POWER key when there is no sensor at the Measuring Receiver's SENSOR input.

RF level measurements are not calibrated, so they are not as accurate as measurements made with an external power sensor as with RF Power measurements. (Refer to *RF Power* on page 3-75.)

PROCEDURE

To make a broadband RF power measurement with an RF cable connected from the signal source to RF INPUT (rather than a power sensor connection), select RF POWER.

To make the measurement with the power sensor connected, key in 35.0 SPCL.

HP-IB PROGRAM CODES

LIN = LN
LOG = LG
RF POWER = M4
SPCL = SP

MEASUREMENT TECHNIQUE

The broadband RF power at RF INPUT is detected by an RF peak detector. The output of the detector is measured and displayed.

When RF Level is selected, the Measuring Receiver sets its RF input attenuation to 50 dB to minimize SWR. Any manual setting of RF input attenuation/gain (Special Function 1) is overridden.

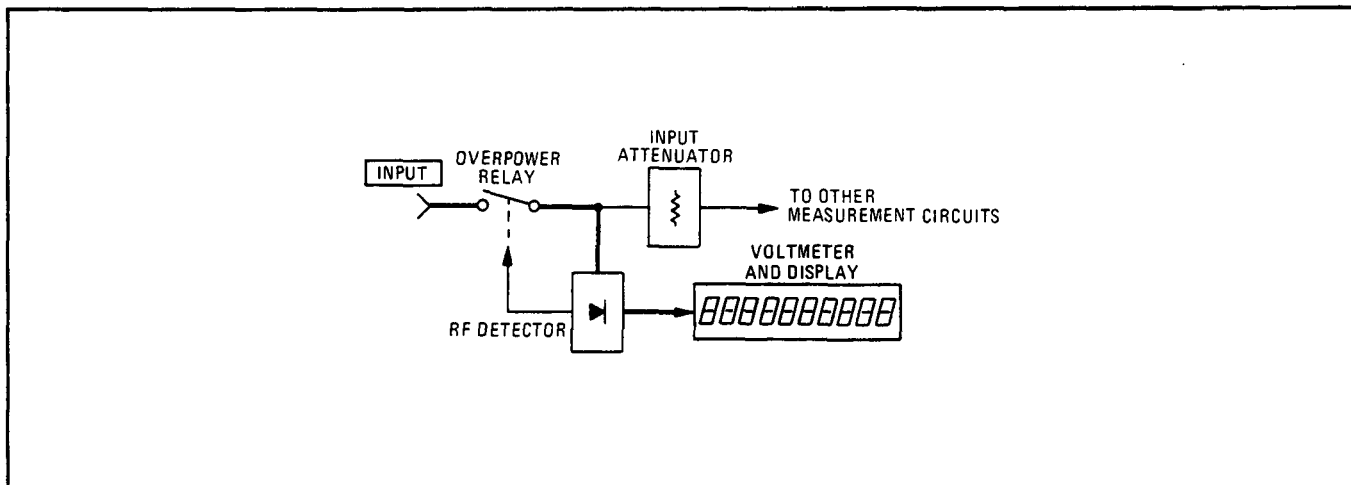

RF Level Measurement Block Diagram

COMMENTS

Input/Output Status.

MODULATION OUTPUT/AUDIO INPUT is turned off during this measurement. However, AM OUTPUT and FM OUTPUT (rear panel) remain active but uncalibrated. The tuning of the instrument remains unchanged.

Relative Measurements.

If RF level is to be displayed relative to a reference, enter the value as a ratio reference using the RATIO key. (Refer to *Ratio* on page 3-245.)

Measuring RF Level on Signals with AM.

If the RF input signal has AM, the peak envelope power is measured.

Previous Input High-Pass Filter Selection.

The input high-pass filter (Special Function 3) remains inserted if previously selected.

Error 06.

The maximum allowable input level is 1W into 50Ω. Input levels greater than 1W cause the overpower relay to open and the display to show Error 06. To reset the relay, remove the input signal and select any measurement key.

Recorder Output

FUNCTIONS

Special Functions 49 and 50 (Display Internal Voltages)

CAUTION

Voltages greater than 10 Vdc applied to the RECORDER OUTPUT could cause damage to the internal circuitry.

DESCRIPTION

The RECORDER OUTPUT makes available the voltage that is being read by the instrument's internal dc voltmeter. Accuracy can be improved for some measurements by connecting to the RECORDER OUTPUT a dc voltmeter that has greater accuracy, linearity, offset, and resolution than the internal voltmeter. This procedure significantly improves the accuracy of the RF Power and Tuned RF Level measurements.

In normal operation, the internal voltmeter is constantly taking readings at various points throughout the instrument as part of its measurement process. The signal at the RECORDER OUTPUT then, is a random series of pulses of varying level. When Special Function 49 or 50 is not enabled, the RECORDER OUTPUT is useful mostly as a troubleshooting aid.

However, Special Functions 49 and 50 can set the internal voltmeter to suspend normal operation and to measure one input only. The voltmeter's input is displayed and delivered to the RECORDER OUTPUT. This feature has two general applications: data logging (for example on a stripchart recorder) and accuracy improvement.

Special Functions 49 and 50 are Service Special Functions which are documented more fully in *Section 8 of the Service Manual*. Use the following partial list of Special Functions to "freeze" the instrument (no ranging, retuning, etc.) and deliver to the RECORDER OUTPUT a dc voltage equal to the level being read by the internal dc voltmeter:

Special Function	Measurement Voltage Displayed and Delivered to RECORDER OUTPUT
49.00 SPCL	Ground
49.01 SPCL	RF Peak Detector Ground
49.02 SPCL	RF Peak Detector (divide by 3)
49.03 SPCL	RF Peak Detector
49.04 SPCL	x10 AM Calibrator
49.05 SPCL	x1 AM Calibrator
49.06 SPCL	Audio Range Detector
49.07 SPCL	RMS-to-DC Converter
49.09 SPCL	Audio Average Detector
49.0A SPCL*	Audio Peak Detector
49.0B SPCL*	IF Average Detector
49.0D SPCL*	IF Peak Detector
49.0E SPCL*	ALC Current
49.0F SPCL*	RF Average Power**
50.06 SPCL	IF Synchronous Detector(without DC-to-RMS Converter)
50.07 SPCL	IF Synchronous Detector(with DC-to-RMS Converter)

* A is Gold Shift, 0; B is Gold Shift, 1; D is Gold Shift, 3; E is Gold Shift, 4; and F is Gold Shift, 5; "B" is displayed as "b" and "D" as "d". For HP-IB programming use "X" in place of the Gold Shift Key.

** For this Special Function, precede with Special Function 0.212. Ignore the display after keying in Special Function 0.212.

PROCEDURE

To do analog data logging with the Measuring Receiver:

1. Connect the logging device to the RECORDER OUTPUT.
2. Select the desired measurement. Since the instrument will not be safeguarded (no ranging, retuning, error messages, etc.), be sure the instrument is set up properly for worst-case expected signal conditions.
3. Key in the appropriate special function using the preceding table as a guide.

NOTE

The measurement unit is volts. Readings in excess of 4 are not valid. Most measurements satisfy calibration requirements since the measured voltage is directly proportional to the normal measurement display. For example, if a normal FM reading is 35.0 kHz, a RECORDER OUTPUT of 3.50, using Special Function 49.0A, corresponds to 35.0 kHz peak FM deviation.

For data logging RF power, use the following procedure.

To increase accuracy of RF Power measurements:

1. Connect an accurate dc voltmeter to the RECORDER OUTPUT. The voltmeter should have at least a 1 MΩ input impedance. Let the instruments warm up for at least one-half hour.
2. Connect a compatible power sensor or sensor module to the SENSOR input. Connect the power sensor's input to the CALIBRATION RF POWER OUTPUT.
3. Select RF POWER, then ZERO. Wait for the ZERO key light to go out.

- Key in the following Special Functions in order and record the external dc voltmeter readings. (The "S" in the Special Function code is the Gold Shift key. After keying in S 5, an "F" is displayed.)

Special Function	Variable Name	Voltmeter Reading in V
10.3, 0.212, 49.0 S 5	V_{z3}, V_{z4}, V_{z5}	_____
10.2, 0.212, 49.0 S 5	V_{z2}	_____
10.1, 0.212, 49.0 S 5	V_{z1}	_____

NOTE

For best accuracy on the most sensitive range (range 1), the zero offset voltage (V_{z1}) should be averaged for many voltmeter measurement cycles. This is most easily done via a programmable voltmeter under HP-IB control.

- Key in 10.0 SPCL then CALIBRATE. Key in 49.0, S, 5, SPCL. Record the voltmeter reading (V_c). Select SAVE CAL (Blue Key and CALIBRATE key) to calibrate the Measuring Receiver's display. The display should read 1 mW.

$$V_c = \text{_____} V$$

- Select SPCL twice. Record the least-significant digit (the tenth digit) on the display (R_c). (This digit indicates the RF Power range for the calibration.)

$$R_c = \text{_____}$$

- Select AUTOMATIC OPERATION. Select CALIBRATE to turn off the Recorder Output Mode.

- Connect the signal source to the power sensor's input. Allow the Measuring Receiver to make a normal RF power measurement.

- Key in 0.212 SPCL. Key in 49.0 S 5 and record the voltmeter reading (V_p).

$$V_p = \text{_____} V$$

- Select SPCL twice. Record the least-significant digit (the tenth digit) on the display (R_p). (This digit indicates the RF Power range.)

$$R_p = \text{_____}$$

- Compute the RF power (P , in mW) from the following formula:

$$P = \frac{CF_c}{CF_p} \times \frac{V_p - V_z R_p}{V_c - V_z R_p} \times 10(R_p - R_c)$$

where

CF_c is the reference (50 MHz) calibration factor from the chart on the power sensor;

CF_p is the calibration factor at the signal frequency from the chart on the power sensor;

$V_z R_c$ is the voltage from step 4 for range R_c ;

$V_z R_p$ is the voltage from step 4 for range R_p .

- Begin subsequent RF power measurements at step 2 as long as the results of step 4 exhibit drift; otherwise, begin at step 9.

COMMENTS

For further details on Special Functions 49 and 50, refer to Service Special Functions in *Section 8*.

Internal Voltmeter Offset.

The RF power circuits do not zero to 0V. Instead they “zero” to between 0.5V and 0.8V which permits the internal dc voltmeter to operate over its most linear range. The internal controller subtracts this offset from subsequent power readings.

Tuned RF Level

FUNCTIONS

Synchronous and Average TUNED RF LEVEL, CALIBRATE, SET REF, Special Functions 38 and 39 (Display and Enter Tuned RF Level Calibration Factors), Special Function 4 (Tuned RF Level Selection and Display Averaging)

DESCRIPTION

The Measuring Receiver can accurately measure the absolute or relative level of extremely low-level, continuous wave (CW), RF signals. At each measurement frequency, the instrument must be calibrated to correct for frequency-dependent measurement variations. Calibration over the full dynamic range requires calibration at three different levels. The calibration remains valid for any CW signal at that frequency $\pm 5\%$ (or ± 10 MHz, whichever is smaller).

Requirements for the Tuned RF Level Measurement

Before an absolute Tuned RF Level measurement can be made, the following 3 requirements must be met. Before a relative Tuned RF Level measurement can be made, only requirements 2 and 3 must be met (since no power sensor is used during relative measurements):

1. The RF Power measurement must be calibrated.

The accuracy of the Tuned RF Level measurement depends on a calibrated RF Power measurement made with an external power sensor. (RF Power calibration is discussed in detail in *RF Power* on page 3-75.)

2. The Measuring Receiver must be properly tuned.

The Measuring Receiver can be tuned manually or automatically. When manually tuning, enter a frequency value into the Measuring Receiver within ± 2.5 kHz for frequencies ≤ 2.5 MHz, within ± 2 kHz for frequencies between 2.5 MHz and 10 MHz, and within ± 50 kHz for frequencies ≥ 10 MHz. When automatically tuning, select **FREQ** and ensure that the initial input signal level is greater than -20 dBm. (*RF Frequency Tuning* on page 3-141 has more details on the different types of tuning available.)

3. The Tuned RF Level calibration factors for the frequency being measured must be in place.

To calibrate the Tuned RF Level measurement (and allow the Measuring Receiver to create calibration factors), step the input signal down and select the **CALIBRATE** key (while keeping the signal level constant) each time **RECAL** is displayed. Each time the **CALIBRATE** key is pressed, the Measuring Receiver creates a calibration factor from a comparison of the two measured levels.

Up to three calibration factors will be created. These three Tuned RF Level calibration factors remain valid regardless of power level as long as the signal frequency is the same.

Each individual calibration factor is tagged with the frequency at which it is valid, and the status of the first three filters in the front of the instrument (Special Function 3 and Special Functions 1.0 and 1.9). If any of these conditions change, the calibration factor becomes invalid.

The Tuned RF Level measurement must be recalibrated if the frequency is changed.

Tuned RF Level calibration can be performed during the actual measurement. Tuned RF Level calibration factors can be entered (using the Store/Recall function or Special Functions 38 and 39) if you have measured that frequency before.

Sensitivity vs. Selectivity; Special Function 4

Tuned RF level measurements can be made with one of two internal detectors: a narrow-band, tracking IF synchronous detector (4.0 SPCL) or a wider-band IF average detector (4.4 SPCL). The IF synchronous detector is more sensitive (it measures to -127 dBm) than the average detector (it measures to -113 dBm). Although the IF synchronous detector can track a drifting input signal over a ± 5 kHz range, it is less tolerant of signal drift and residual FM than the IF average detector. When measuring noisy signals, use the IF average detector (4.4 SPCL). The IF synchronous detector (4.0 SPCL) is automatically selected on power-up.

If the signal drifts too much even for the IF average detector, use track mode tuning with this detector (not available with the IF synchronous detector). Refer to *Comments*, "Special Function 32.9; Tuned RF Level Measurements Using Track Mode Tuning" on page 3-105.

Storing Calibration Factors for the Tuned RF Level Measurement

Calibration at every frequency of interest is time consuming. So, when making repetitive Tuned RF Level measurements at many different frequencies, use the Store/Recall function to recall the calibration factor for each frequency of interest. Eight storage registers are available. If more than eight frequencies are to be measured, use Special Functions 38 and 39 to display and enter the calibration factors for each frequency of interest. A procedure below explains how to use these special functions.

PROCEDURE

The following procedures are provided in this *Procedure* section:

1. Calibration for Absolute Measurements
 - a. Using a Sensor Module³: Calibrating a Tuned RF Level Measurement.
 - b. Using a Power Sensor: Calibrating a Tuned RF Level Measurement.
2. Calibration for Relative Measurements.
3. Using Special Function 4 To Select the IF Detector.
4. Using Special Functions 38 and 39 to Display and Enter Tuned RF Level Calibration Factors.
 - a. Special Function 38; Display Tuned RF Level Calibration Factors.
 - b. Special Function 39; Enter Tuned RF Level Calibration Factors.
 - c. Considerations When Using Special Functions 38.

CALIBRATION FOR ABSOLUTE MEASUREMENTS

Before attempting one of these procedures, be sure that 1) the RF Power measurement is calibrated, 2) the input signal is within the range required by the power sensor but not greater than 0 dBm (for example, 0 to -20 dBm for the HP 11722A), and 3) the Measuring Receiver is properly tuned. The following procedures enable the Measuring Receiver to obtain its calibration factors for the frequency being measured.

Two procedures are provided. If a sensor module is used, use the first procedure. If a power sensor only is used, use the second procedure.

³ A sensor module contains a power sensor path and a through path for RF measurements as well as an RF switch to switch between the two paths. The Measuring Receiver controls the switching of the input signal depending on the measurement selected. Examples of sensor modules are the HP 11722A and the HP 11792A.

Using a Sensor Module: Calibrating a Tuned RF Level Measurement

1. Select INSTR PRESET (Blue Key, AUTOMATIC OPERATION). (Since the Frequency measurement is automatically selected with INSTR PRESET, the instrument tunes to the signal at this time.)
2. Connect the sensor module to the RF source. The signal level should be greater than -20 dBm.
3. If the measurement can be made and the display is stable, go to the next step. (You will be using the IF synchronous detector.) If the input signal is noisy or has display jitter, select 4.4 SPCL. (You will be using the IF average detector.) The Measuring Receiver will not be able to make a measurement on a signal that has too much noise.
4. Select TUNED RF LEVEL (S, RF POWER); wait for the measurement result to be displayed. Observe the RECAL annunciator in the display. (If RECAL is not displayed and the sensor module has not been changed since the last calibration, go to step 7.)
5. the LOG/LIN key enables the Measuring Receiver to display the result in either logarithmic or linear units. If desired, select LOG/LIN to change the displayed units.
6. Do not change the input signal while pressing the CALIBRATE key to enable the Measuring Receiver to create a calibration factor for the first range. Wait for the CALIBRATE light to go out before stepping the input signal further.
7. Tuned RF level measurements can now be made, but as the signal level is stepped down its full range, the RECAL annunciator will be displayed up to two more times when recalibration is required. (When the RECAL annunciator lights, do not change the source level.) Select CALIBRATE. Then wait until the light in the CALIBRATE key goes out before stepping the input signal further. Selecting the CALIBRATE key enables the Measuring Receiver to create a second and third calibration factor.

(If the RECAL annunciator is no longer displayed, but the UNCAL annunciator is displayed, re-adjust the source level until the RECAL annunciator lights, then select CALIBRATE.)

Using a Power Sensor: Calibrating a Tuned RF Level Measurement

1. Select INSTR PRESET (Blue Key, AUTOMATIC OPERATION).
2. Connect a power sensor between the output of the RF source and the SENSOR input of the Measuring Receiver. Input a signal with an amplitude value within the range of the power sensor.
3. Manually tune the Measuring Receiver by entering the frequency of the RF source into the Measuring Receiver. The display should read “- -”.
4. Select AUTO TUNING (Blue Key, TRACK MODE). The display will again read “- -”.
5. Select TUNED RF LEVEL (S, RF POWER). Wait for a display of “- -”.
6. Select CALIBRATE. Again wait for the “- -”.
7. Disconnect the power sensor from the signal source. Connect the signal source to the Measuring Receiver's RF INPUT. Wait for the CALIBRATE key to go out and a valid measurement result to be displayed.
8. If the measurement can be made and the display is stable, go to the next step. (You will be using the IF synchronous detector.) If the input signal is noisy or has display jitter, select 4.4 SPCL. (You will be using the IF average detector.) The Measuring Receiver will not be able to make a measurement on a signal that has too much noise.

NOTE

If a valid measurement result is not displayed, manually tune the Measuring Receiver again by entering the frequency of the RF source into the Measuring Receiver. If manually tuning the signal does not display a valid measurement result, start the procedure from the beginning.

9. The LOG/LIN key enables the Measuring Receiver to display the result in either logarithmic or linear units. If desired, select LOG/LIN to change the displayed units.
10. Tuned RF level measurements can now be made, but as the signal level is stepped down its full range, the RECAL annunciator will be displayed up to two more times when recalibration is required. When the RECAL annunciator lights, hold the source level steady, select CALIBRATE, and wait until the light in the CALIBRATE key goes out. Selecting the CALIBRATE key enables the Measuring Receiver to create a second and third calibration factor.

(If the RECAL annunciator is no longer displayed, but the UNCAL annunciator is displayed, re-adjust the source level until the RECAL annunciator lights, then select CALIBRATE.)

CALIBRATION FOR RELATIVE MEASUREMENTS ⁴

Even though no power sensor is used, the Measuring Receiver still makes a reference measurement (the value you set to be 0 dB) and calibrates subsequent ranges to that value. Use the following procedure for relative Tuned RF Level measurements:

1. Select INSTR PRESET (Blue Key, AUTOMATIC OPERATION). (Since the Frequency measurement is automatically selected with INSTR PRESET, the instrument tunes to the signal at this time.)
2. Connect an RF cable between the output of the RF source and the RF INPUT of the Measuring Receiver. The signal level should be greater than -20 dBm.
3. If the input signal is stable, go to the next step. (You will be using the IF synchronous detector.) If the input signal is noisy or has display jitter, select 4.4 SPCL. (You will be using the IF average detector.)
4. Select TUNED RF LEVEL (S, RF POWER); wait for the uncalibrated display.
5. Tuned RF level measurements can now be made, but as the signal level is stepped down its full range, the RECAL annunciator will be displayed up to two more times when recalibration is required. When the RECAL annunciator lights, hold the source level steady, select CALIBRATE, and wait until the light in the CALIBRATE key goes out. Selecting the CALIBRATE key enables the Measuring Receiver to create a second and third calibration factor.

(If the RECAL annunciator is no longer displayed, but the UNCAL annunciator is displayed, re-adjust the source level until the RECAL annunciator lights, then select CALIBRATE.)
6. Set the RF level of the source to the level that is to be used as a reference. (Select the LOG/LIN key to change the display to the preferred display of % or dB.)
7. Select SET REF (Blue Key, ZERO). The display should read approximately 100% or 0 dB. Subsequent measurements will be made relative to this level.

⁴ More information about relative Tuned RF Level measurements can be found in *Attenuator Measurements*.

USING SPECIAL FUNCTION 4 TO SELECT THE IF DETECTOR

Special Functions 4.0 through 4.3 select the IF synchronous detector. Special Functions 4.4 through 4.7 the IF average detector.

Special Functions 4.1 through 4.3 and 4.5 through 4.7 enable manual selection of the measurement display averaging time for each detector. The Measuring Receiver automatically selects these if Special Function 4.0 or 4.4 is selected. It is usually unnecessary to manually select these times. (Refer to *Comments*, "Special Function 4 Also Controls Selection of Measurement Display Averaging".)

To select the IF synchronous detector, select 4.0 SPCL. (This detector is selected on power-up or after INSTRUMENT PRESET or AUTOMATIC OPERATION is selected.)

To select the IF average detector, select 4.4 SPCL.

To manually select the display averaging time refer to *Comments*, "Special Function 4 Also Controls Selection of Measurement Display Averaging".

MAKING TUNED RF LEVEL MEASUREMENTS WITH OPTION 050

Instruments equipped with Option 050, Increased Power Measurement Accuracy, provide tuned RF level measurement accuracy of ± 0.012 dB ± 0.005 dB per 10 dB for absolute power measurements, and ± 0.014 dB ± 0.005 dB per 10 dB step for relative power measurements. These instruments have been calibrated to -120 dBm in compliance with MIL-STD-45662 using calibration standards traceable to the National Bureau of Standards.

Requirements for Option 050 Measurements. The accuracy specifications provided by Option 050 are warranted when using an HP synthesized signal source with less than 100 Hz peak residual FM measured in a 3 kHz post-detection bandwidth over a 30 second period. This allows the HP 8902A to use its narrow band IF synchronous detector.

Procedure for Making Option 050 Measurements.

1. Select Special Function 32.1 to increase the HP 8902A's display resolution to 0.001.
2. Select Special Function 4.1 to increase the averaging time to 10 seconds. (The increased averaging minimizes any digit flicker.)
3. Adjust the source level to between -10 dBm and 0 dBm for absolute measurements, or set the reference within ± 0.003 dB for relative power measurements.
4. Perform the calibration procedures described in this section for the type of Tuned RF Level measurement you wish to make (absolute or relative).

Considerations When Making Option 050 Measurements

Making Relative Level Measurements. The closer the reference source level is set to 0 dBm when performing the initial tuned RF level calibration the greater your calibration certainty will be when starting your relative measurements.

To achieve the greatest resolution, adjust the source level to the top of the IF synchronous detector's range. To do this, select the Tuned RF Level measurement and then key in Special Function 50.05 (or 48.0). The HP 8902A will display the rms voltage level at the detector. Increase the voltage level to approximately 3 Vrms to optimize measurement resolution.

Residual Noise Level. The residual noise level of the HP 8902A increases in its lowest tuned RF level range.

Minimizing Mismatch Uncertainty. The accuracy specifications for Option 050 do not include mismatch uncertainty. A 10 dB pad positioned at the HP 8902A's input and a 10 dB pad at the source's output can help minimize mismatch uncertainty. Also, using well shielded cables can help reduce leakage.

USING SPECIAL FUNCTIONS 38 AND 39 TO DISPLAY AND ENTER TUNED RF LEVEL CALIBRATION FACTORS

These functions are especially useful in remote operation when making repetitive Tuned RF Level measurements at many different frequencies. After a measurement is calibrated, you can display the calibration factors for that frequency using Special Function 38. These values can then be re-entered using Special Function 39. When operating the instrument remotely, measurement time is decreased when it is not necessary to perform calibration. (Note: if the number of test frequencies is less than or equal to eight, consider using the Store/Recall function.)

To display and then re-use Tuned RF Level calibration factors, perform calibration at the frequency of interest; read the calibration factors using Special Function 38 (and record the values somewhere; for example, in a test program).

Then re-enter the calibration factors using Special Function 39 before making measurements at that frequency. (Before using Special Function 39, ensure that the instrument is tuned to the same frequency as calibrated at before.)

Special Function 38; Display Tuned RF Level Calibration Factors.

38.1 Display the calibration factor for Range #1.

38.2 Display the calibration factor for Range #2.

38.3 Display the calibration factor for Range #3.

38.4⁵ Display the SET REF reference calibration value. (This value is displayed with a maximum of eight digits and a resolution of 0.01%.)

To display Tuned RF Level calibration factors:

- a. Select the TUNED RF LEVEL mode.
- b. Perform calibration for either absolute or relative Tuned RF Level measurements as described in the previous paragraphs.
- c. Select 38.N SPCL (where N is the desired suffix)
- d. Select % CAL FACTOR (Blue Key, MHz).
- e. Record the displayed value.

⁵ This special function is not available with firmware date codes 234.1985 and below (To display the firmware date code, select 42.0 SPCL.) To order a ROM set that contains this special function, contact the nearest HP sales office.

Special Function 39; Enter Tuned RF Level Calibration Factors.

- 39.1 Enter the calibration factor for Range #1.
- 39.2 Enter the calibration factor for Range #2.
- 39.3 Enter the calibration factor for Range #3.
- 39.4⁶ Enter the SET REF calibration reference value.
- 39.9 Clear all calibration factors.

To enter Tuned RF Level calibration factors:

- a. Select the TUNED RF LEVEL mode.
- b. Select 39.N SPCL (when N is the desired suffix). The input signal level will be displayed.
- c. Key in the desired calibration factor value (for example, 120).
- d. Select % CAL FACTOR (Blue key, MHz).

Considerations When Using Special Functions 38 and 39.

- Since different Tuned RF Level calibration factors are created depending on the IF detector being used (4.0 SPCL or 4.4 SPCL), the first calibration factor (38.1 SPCL) should be reselected when re-entering the first calibration factor (391 SPCL). The second and third calibration factors do not depend on the IF detector being used. (for more information about this consideration, refer to *Comments*, “4.0 SPCL, 4.4 SPCL, and SET REF affect the First Calibration”)
- The state of Special Function 3 must remain the same when re-entering Tuned RF Level calibration factors.
- The state of Special Function 1.0 or 1.9 must remain the same when re-entering Tuned RF Level calibration factors.

EXAMPLE

To enter a Tuned RF Level Calibration Factor of 120 % for the RF power range 1:

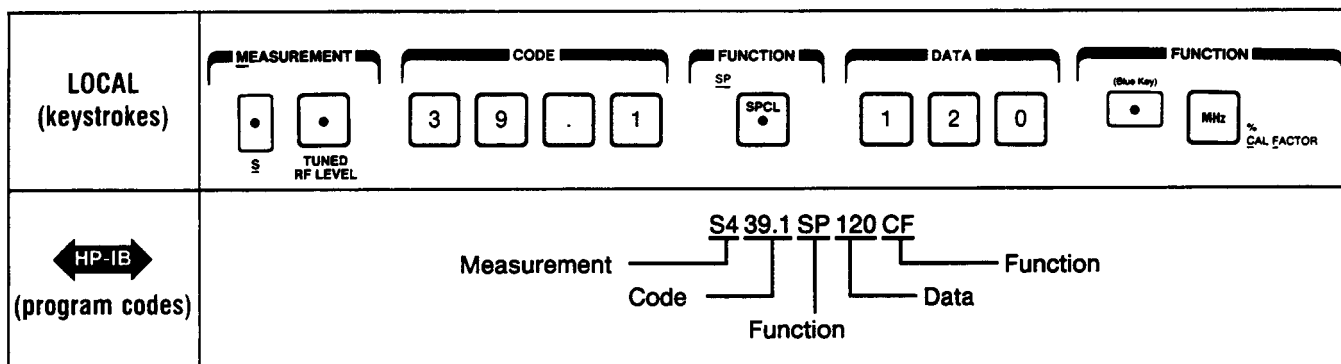

⁶ This special function is not available with firmware date codes 234.1985 and below. (To display the firmware date code, select 42.0 SPCL.) To order a ROM set that contains this special function, contact the nearest HP sales office.

HP-IB PROGRAM CODES

CALIBRATE on = C1	VOLTS units = VL
CALIBRATE off = C0	mV units = MV
% CAL FACTOR = CF	μ V units = UV
LIN results = LN	WATTS units = WT
LOG results = LG	
TUNED RF LEVEL = S4	

INDICATIONS

During routine measurement:

When TUNED RF LEVEL is selected, the following responses are displayed: four dashes (----) to indicate the signal has been found, then six dashes (-----) to indicate the instrument is fine tuning to the signal, then four again (----) to indicate settling. If two dashes (--) are displayed, no signal can be found.

Six dashes (-----) will not be displayed if the Average Tuned RF Level measurement is selected.

MEASUREMENT TECHNIQUE

The tuned RF level measurements use an IF substitution technique to attain high measurement accuracy over a wide range of signal levels. The basic measurement technique is discussed in Tuned RF Level. The discussion that follows focuses on calibration details.

Power Calibration

An initial absolute power level calibration is made by applying a signal to the Measuring Receiver via a calibrated power sensor. The signal must be within both the sensor's and Measuring Receiver's power and frequency range. (Power should not exceed 0 dBm.) An initial relative power level calibration is made by applying a signal to the Measuring Receiver's RF INPUT and selecting SET REF.

The absolute power is first measured with the calibrated power sensor. The signal is then routed to the RF INPUT connector of the instrument where the level is measured by the IF detector. (If using a sensor module with an internal switch, such as the HP 11722A, the switching is automatic. If using a power sensor alone, the signal source must be reconnected to the instrument's RF INPUT connector.) The signal level must be held steady during calibration.

The first time the CALIBRATE key is selected, the Measuring Receiver compares the level read by the Tuned RF Level IF detector to the reference level. The ratio of the two measurements is stored as a calibration factor. (The reference level for absolute measurements is the RF Power measurement, the reference level for relative measurements is the set by the user with the SET REF key.)

The calibration factors are used to compensate for the non-linearity of the RF input gain steps (Special Function 1).

RF Input Ranging Calibration

As the power level of the input signal is varied, the IF amplifier gain is stepped to keep the IF level within the linear range of the IF detector. When the IF level approaches the lower limit of the IF range, the RF input attenuation is reduced to nominally 10 dB. The IF gain then compensates for the change in RF input attenuation.

The Calibrate function enables the Measuring Receiver to create a second calibration factor by equating the power level measured before the RF range change with the power level after the change. (The input signal level must not change during this recalibration.) This new calibration

factor is multiplied by the calibration factor made previously (with the reference) to be used in all subsequent measurements for that RF range and frequency.

A third recalibration is required if the input signal level approaches the lower limit of the IF detector in the second IF range. This time, RF input gain (24 dB) is added and IF gain is reduced and a third calibration factor is created for that RF range and frequency. The three calibration factors remain in effect as long as the frequency of the input signal is within $\pm 5\%$ of the initial frequency.

Calibration Limitations

The approximate limits of the three RF ranges for both the IF synchronous and average detectors are shown in the following graphs. The ranging points used in Automatic Operation are also indicated. (The range can be held manually. Refer to *Range Hold* on page 3-243.) The range limits listed for the Power Reference Range apply only for power sensors with the same sensitivity as the HP 11722A Sensor Module. Other sensors might shift the Power Reference Range up or down (but 0 dBm is the overall maximum level).

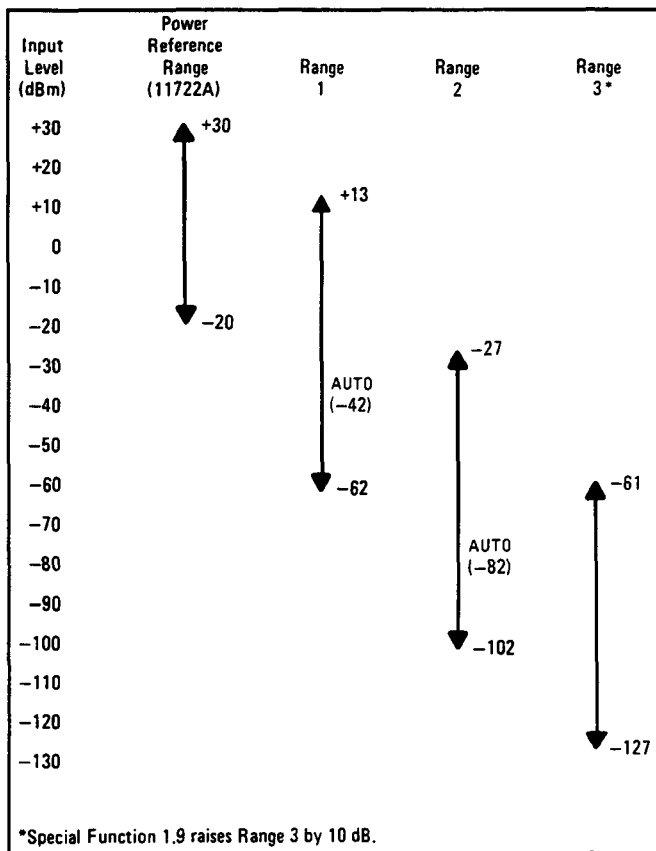

Synchronous Tuned RF Level Ranges

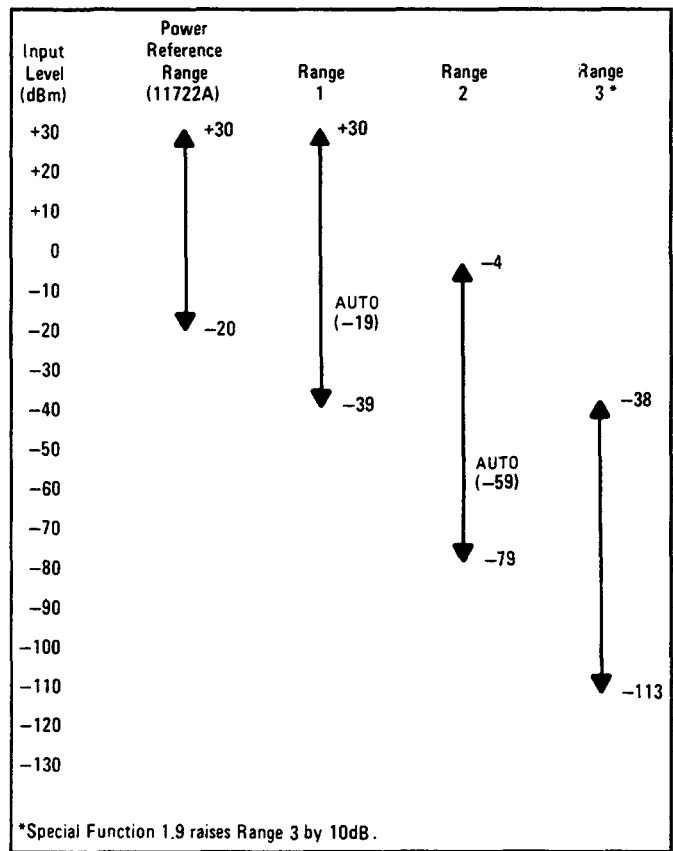

Average Tuned RF Level Ranges

The absolute power reference for many power sensors may overlap ranges other than the top range, it is possible to make the initial calibration against the power sensor on Range 2 or 3 (or even in the overlap region of two ranges) instead of Range 1.

IF Detectors and Filters After the IF signal has been detected, the dc output from the detector is filtered and read by the internal voltmeter. Filtering combines a 10 Hz, low-pass filter in hardware

with digital averaging of successive voltmeter readings in software. Measurements can be averaged for 0.1, 1, and 10s. The equivalent noise bandwidths are 10, 1, and 0.1 Hz respectively. The 10 Hz low-pass filter is always in.

A narrow 455 kHz IF bandpass filter (30 kHz passband) improves sensitivity to enable the instrument to measure low-level signals (where the signal-to-noise ratio is very poor). This filter primarily determines the frequency response for the 455 kHz IF and is bypassed when not needed.

Measurement sensitivity is further improved by the IF synchronous detector which locks onto and tracks the IF signal. Tracking is maintained over a 10 kHz range. Phase locking, coupled with the synchronous detection technique, reduces the measurement bandwidth to 150 Hz—giving a corresponding increase in sensitivity.

The phase lock loop locks a 455 kHz voltage-controlled oscillator (VCO, not shown in the block diagram) to the IF signal. The locked VCO then becomes the synchronized drive to the detector. As the IF signal drifts, the VCO drifts with it to maintain synchronism.

The instrument's controller monitors the detector output to determine if lock has been acquired. If no signal is sensed, the controller initiates a search routine that sweeps the VCO over the IF bandwidth. During this search, six dashes (-----) are displayed. If four dashes (----) are displayed after the search, the signal has been found. If two dashes (--) are displayed, no signal has been found. The sweep can take up to 20s.

Tuned RF Level measurements made with the IF average detector are similar to those made with the IF synchronous detector except that the AM detector, operating with its ALC loop open, is used to measure the IF level. (Refer to AM on page 3-162 for the block diagram.) The IF average detector does not phase lock to the signal as the IF synchronous detector does, so the measurement bandwidth is much wider and enables measurement of less pure signals.

The wide 455 kHz bandpass filter (200 kHz passband) primarily determines the frequency response for the 455 kHz IF.

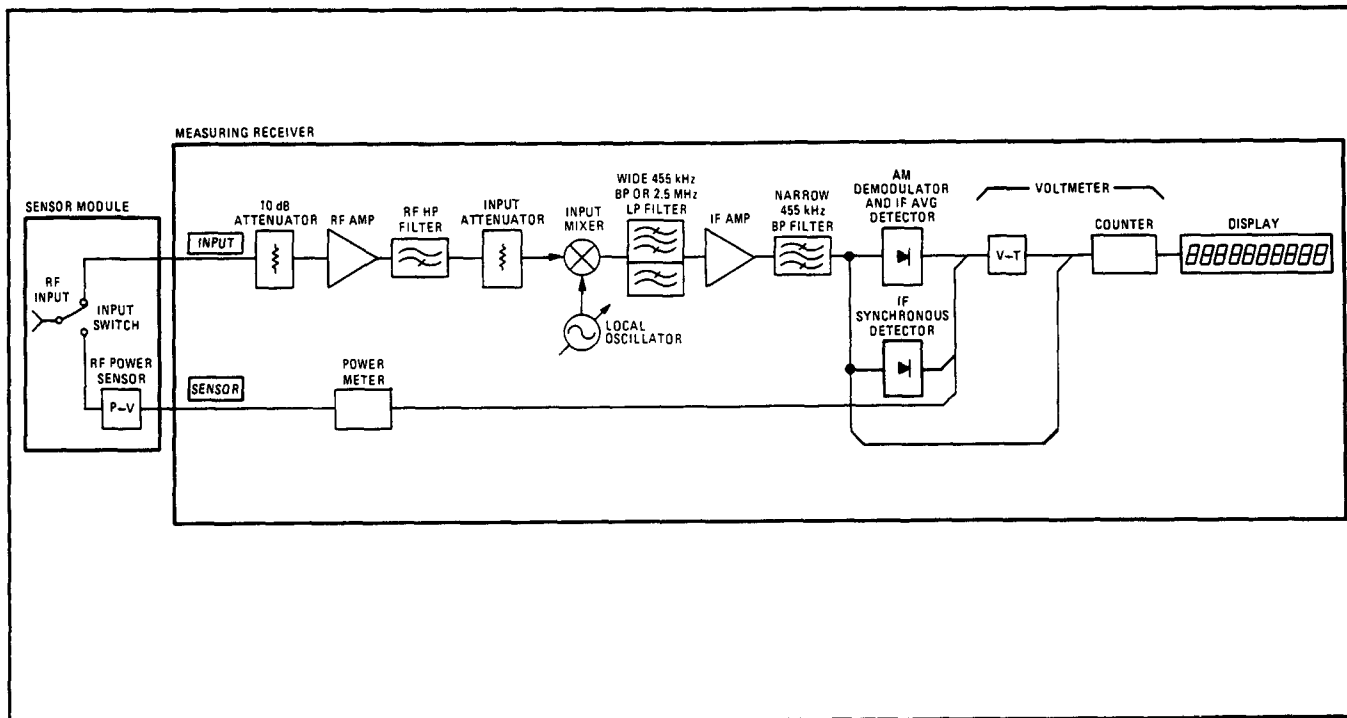

Tuned RF Level Simplified Block Diagram

Calibration Factors

An individual calibration factor is computed for each RF range-to-range change by comparing the level measured during the initial power sensor calibration to the level measured for each RF range. This individual level measurements are ratioed to determine the relative, range-to-range calibration factors actually used in tuned RF level measurements. Display the individual calibration factors with Special Function 38. Display the ratioed calibration factors with the % CAL FACTOR key.

The following table describes the equations used to calculate the ratioed calibration factors using individual calibration factors.

In this table, the Power Reference Range is the range used for initial calibration to the power sensor, and CF_1 , CF_2 , and CF_3 are the "individual" calibration factor values for the range reference to 1, to 2, or 3 (respectively)

Power Reference Range	Current Range		
	1	2	3
1	CF_1	CF_1CF_2	$CF_1CF_2CF_3$
2	$\frac{CF_2}{CF_1}$	CF_2	CF_2CF_3
3	$\frac{CF_3}{\frac{CF_2}{CF_1}}$	$\frac{CF_3}{CF_2}$	CF_3

Only four calibration factors are retained in the instrument's non-volatile memory. Separate calibration factors are maintained for the Power Reference Range of both the IF synchronous and IF average detectors; the calibration factors for subsequent ranges are shared by both detectors.

If no actual calibration factors are available, an approximate calibration factor (accurate within a few dB) is derived.

COMMENTS

If the Tuned RF Level Calibration Is Not Possible.

If the Measuring Receiver is not making the measurement, it is probably because calibration is not possible. Following the guidelines below may enable the Measuring Receiver to complete a Tuned RF Level measurement:

- Change the level of the input signal until only the RECAL annunciator is displayed.
- Calibrate the power sensor. (Refer to *RF Power* on page 3-75.)
- Change the IF Gain to automatic selection (9.0 SPCL).
- Change the RF Input Attenuation and Gain to automatic selection (1.0 or 1.9 SPCL).
- Ensure that the input-signal level does not change when the CALIBRATE key is pressed.

Recovering from Mistakes in Entering Calibration Factor Values.

If an error is made in entering any calibration factor value with Special Function 39, selecting CLEAR allows the user to immediately re-entering the Special Function Code.

Calibration Factors Valid for a Frequency Change of $\pm 5\%$ or ± 5 MHz When Track-Mode Tuning Is Not Used.

The calibration factors obtained during calibration are valid and are used by the instrument as long as the signal frequency remains within $\pm 5\%$ of the frequency of the signal at calibration (or ± 5 MHz, whichever frequency is less). However, because of tuning limitations, a frequency change of ± 5 MHz necessitates retuning, but the previous calibration factors will be retained unless the $\pm 5\%$ or ± 5 MHz limit has been exceeded.

Finer Resolution for dB Measurements ⁷

Special Function 32.1 enables a resolution of 0.001 dB. (For audio frequency measurements, this special function also enables a resolution of 0.1 Hz for frequencies for 100 to 250 kHz instead of the normally displayed resolution of 1 Hz.) The selection of Special Function 32.0 or 32.1 is maintained through instrument power down.

32.0 Power is displayed with the normal measurement resolution of 0.01 dB.

32.1 Power is displayed with a measurement resolution of 0.001 dB.

32.2 Displays 0 if the normal measurement resolution is enabled (32.0 SPCL) and displays 1 if a finer resolution is enabled (32.1)

Special Function 32.9; Tuned RF Level Measurements Using Track-Mode Tuning. ⁸ Use this special function when making level measurements on low-level signals (greater than 40 MHz into the HP 8902A) that tend to drift. The track mode tuning is available only with the IF average detector (Special Functions 4.4 through 4.7) which can measure levels to -110 dBm. (Note that Special Functions 32.1 and 32.9 can be enabled simultaneously.)

To select track-mode tuning for a low-level Tuned RF Level measurement:

- a. Instrument Preset the HP 8902A (blue key, green key).
- b. If using a down converter to measure microwave signals, key in 27.3 SPCL. Key in the external L.O. frequency. Make sure that the L.O. frequency results in an IF frequency to the HP 8902A of greater than 40 MHz when mixed with the RF signal.
- c. Set the RF signal to a level greater than -10 dBm.
- d. Allow the HP 8902A to tune to the signal. (Wait for a frequency display.)
- e. Select 32.9 SPCL. (This is the same as entering 4.4 SPCL, 8.1 SPCL, Log units, Track Mode and 27.3 SPCL.) The light in the TRACK MODE key should be on at this point.
- f. Press the MHz key to enter the manual tune mode.
- g. Select Tuned RF Level (yellow shift key, RF Power key).
- h. If using an HP 11722A or HP 11792A sensor module, press the CALIBRATE key to make an absolute level measurement or set a relative reference by pressing the blue key and the ZERO key.
- i. Step the signal level down in amplitude and press the CALIBRATE key whenever the RECAL annunciator is displayed.

⁷ This special function is not available with firmware date codes 234.1985 and below. (to display the firmware date code, select 42.0 SPCL.) To order a ROM set that contains this special function, contact the nearest HP sales office.

⁸ Instrument serial-number prefix 2305A to 2530A do not contain this feature. For retrofit information, contact the nearest HP sales office.

Comments About Special Function 32.9.

If the signal appears to be lost, set the signal level of the device-under-test to greater than -90 dBm. Then select Blue Key, CLEAR (HP-IB code: BC). This key sequence forces a retune of the VCO during Tuned RF Level measurements and should recapture the signal if it has not drifted more than 5 MHz. Once the signal has been recaptured, step the signal down for low-level measurements.

If the signal frequency into the HP 8902A drifts past one of the following frequency boundaries, the Measuring Receiver will lose the signal and the measurement process must be restarted.

Frequency Boundaries:

40MHz, 80 MHz, 160MHz, 320 MHz, and 640 MHz.

Special Function 31. Tuned RF Level Noise Correction. ⁹ Use this special function in conjunction with the IF Average Detector (Special Functions 4.4 through 4.7) when making Tuned RF Level measurements on low-level signals. The selection of Special Function 31 is maintained through instrument power down (the Measuring Receiver being turned off and then on).

The Tuned RF Level measurement calibrated three RF input attenuation ranges to achieve accurate low-level measurements. (the *Operating Information Pull-Out Card* illustrates these.) When Special Function 31.1 is enabled, the normal Tuned RF Level measurement procedure is followed (that is, stepping down in level and pressing the CALIBRATE key whenever the RECAL annunciator is displayed.) However, when the Measuring Receiver calibrates the third RF range, it causes the sensor module to switch out the signal from the device-under-test momentarily (placing 50Ω at the output). Then the Hp 8902A measures the noise between the RF input and the IF Synchronous Detector circuitry. In subsequent measurements (in this third range), the Measuring Receiver subtracts the measured noise from the total signal-plus-noise to display the measured signal level.

31.0 Turn off noise correction.

31.1 Turn on noise correction.

31.2 Display 0 if noise correction is off and display 1 if it is on.

Comments About Special Function 31.**NOTE**

Special Function 31.1 (for noise correction) should be entered once before making level measurements. To clear Special Function 31.1 you MUST enter 31.0.

Special Function 31 can be especially useful when making measurements on down-converted signals.

Special Functions 31.0 and 31.1 can be toggled once the Tuned RF Level calibration has been done with 31.1 enabled. That is, the signal can be measured alternately with the noise added to the signal and without the noise.

The Measuring Receiver uses a default noise value (that might be invalid) in its measurement response if Special Function 31.1 is enabled after (instead of before) completing the Tuned RF Level calibration sequence. (The default noise value is the last value that was measured. This value is saved through Instrument Preset and power down.)

⁹ This special function is not available with firmware date codes 234.1985 and below. (To display the firmware date code, select 42.0 SPCL.) To order a ROM set that contains this special function, contact the nearest HP sales office.

CAUTION

Do not use 31.1 SPCL when making any uncalibrated, or relative signal level measurement in Tuned RF Level mode without a power sensor. The Sensor Module must be used when making Tuned RF Level range-to-range calibrations with the AVG Detector.

If You Prefer Manually-Entered RF Power Calibration Factors.

Not to be confused with Tuned RF Level calibration factors. RF power calibration factors are used during the RF Power measurement and during the first Tuned RF Level absolute calibration to compensate the external power sensor's frequency response relative to a 1 mW reference calibration. Selecting AUTOMATIC OPERATION or INSTRUMENT PRESET causes the Measuring Receiver to use Automatic Cal Factors. Any Manual Cal Factor used during RF power calibration is erased when these functions are initiated, and will not be used in the first Tuned RF Level calibration. (Refer to RF Power on page 3-75.)

4.0 SPCL, 4.4 SPCL, and SET REF Affect the First Calibration.

- **For Absolute Measurements.** Different detectors are used by 4.0 SPCL and 4.14 SPCL. (These detectors are described in previous paragraphs.) This means that the first calibration factor will be different depending on the detector used when CALIBRATE is selected the first time. So if the test signal is unstable enough at low levels to require measurement with the average detector, you will need to make a first calibration for both 4.0 SPCL and 4.4 SPCL at the tuned frequency.
- **For Relative Measurements.** Relative Measurements are made with the SET REF key. When you use SET REF, you do not use a power sensor. (If you use a sensor module, the power sensor within it will be bypassed for SET REF measurements.) This means that the first calibration compares the level measured by either detector to the level that you set to be 0 dB when you select the SET REF key. As with absolute measurements, the first calibration factor will be different for each detector.
- **For Both Absolute and Relative Measurements.** Because of these four variables (absolute measurement with either detector and relative measurement with either detector), the first calibration factor can be four different values. However, the second and third calibration factor will be the same for each of these four cases.

Special Function 4 Also Controls Selection of Measurement Display Averaging.

Measurement averaging time is automatically selected by the Measuring Receiver during the Tuned RF Level measurement. Measurement averaging time is automatically selected by the Measuring Receiver during the Tuned RF Level measurement. The Measuring Receiver chooses these times based on the requirements of its internal circuitry. However, experienced operators may want to increase or decrease the measurement time using Special Function 4:

High Residual FM Can Affect Accuracy.

Tuned RF Level measurement accuracy can be affected by residual FM on the input signal. If the residual FM is too high (refer to Table 1-1 for Measuring Receiver specifications), the Average Tuned RF Level Measurement mode can be used

Approximate Measurement When UNCAL is Displayed.

Approximate calibration factors enable the Tuned RF Level measurement until the Calibrate function is used. The UNCAL annunciator indicates that approximate calibration factors are being used.

Attenuator/Gain Automatic Ranging.

The instrument automatically ranges as shown in the "Measurement Technique". Refer to *Range Hold* on page 3-243 for ways to avoid automatic ranging.

High Residual FM Can Affect Accuracy.

Tuned RF Level measurement accuracy can be affected by residual FM on the input signal. If the residual FM is too high (refer to Table 1-1 for Measuring Receiver specifications), the Average Tuned RF Level Measurement mode can be used

Approximate Measurement When UNCAL is Displayed.

Approximate calibration factors enable the Tuned RF Level measurement until the Calibrate function is used. The UNCAL annunciator indicates that approximate calibration factors are being used.

Attenuator/Gain Automatic Ranging.

The instrument automatically ranges as shown in the "Measurement Technique". Refer to *Range Hold* on page 3-243 for ways to avoid automatic ranging.

IF Level

FUNCTIONS

IF LEVEL

DESCRIPTION

The signal level in the Measuring Receiver's IF can be measured and displayed as a percent of the optimum level. An IF level display of 100% indicates sufficient signal strength to guarantee accurate modulation measurements. AM accuracy is directly affected by the IF level. FM and Φ M accuracy is affected only if the IF level is very low.

PROCEDURE

To display the IF level as a percent of optimum, select IF LEVEL (Shift, Φ M).

HP-IB PROGRAM CODE

IF LEVEL = S3

MEASUREMENT TECHNIQUE

Once the instrument is tuned and the IF Level function is selected, the automatic level control (ALC) loop of the AM Demodulator detects the average level of the IF. If the ALC loop is closed and there is sufficient IF signal available, the ALC loop automatically adjusts the IF gain within the loop to force the detected IF to equal the ALC reference. When the instrument is running in automatic operation, the input attenuation is adjusted to keep the IF level within range of the ALC loop.

In the IF Level measurement mode, the detected IF level is compared to the ALC reference and the ratio of the two levels is expressed as a ratio in %. If the ALC loop is closed and if there is sufficient IF level, the display will read 100%. If the ALC loop is open (Special Function 6.2) or if there is insufficient IF level, the display will not read 100%. If the IF level is too high the display will read greater than 100%. If the IF level is too low, the display will read less than 100%.

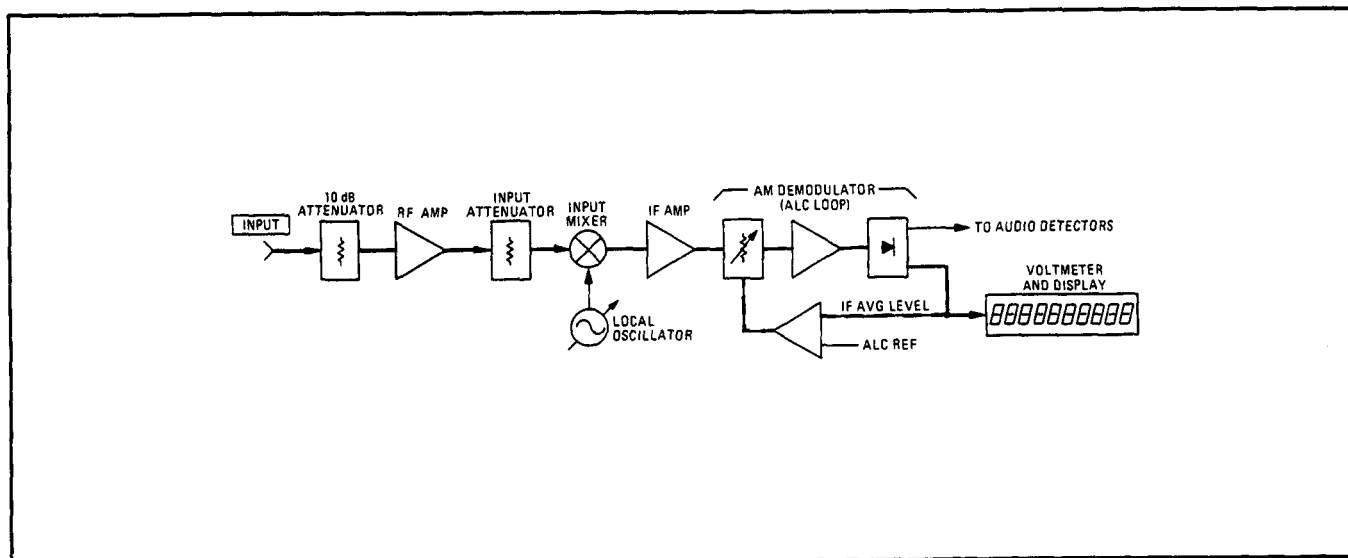
BLOCK DIAGRAM*IF Level Measurement Block Diagram***COMMENTS****Acceptable IF Level Display.**

An IF level display between 99.9% and 100.1% is considered acceptable for all measurements.

Input/Output Status.

When IF LEVEL is selected, the output at MODULATION OUTPUT/AUDIO INPUT continues to output the demodulated signal corresponding to the last modulation measurement selected as indicated by the MODULATION OUTPUT annunciator. If the IF level is not 100%, the calibration of the output is directly affected for AM and degraded for FM and Φ M if the IF level is very low.

Relative Measurements.

If IF level is to be displayed relative to a reference level, enter the ratio reference using the RATIO key. (Refer to *Ratio* on page 3-245.)

IF Levels Less Than 100%.

Error 03 (input circuits underdriven) is generated whenever the IF level is less than 100% unless the ALC loop is open. Override this Error Message using Special Function 8. (Refer to *Error Message Disable Control* on page 3-267.)

AM Depth When IF Level is Insufficient.

When operating with the AM ALC loop open or when the IF level is insufficient, the displayed AM is proportional to the actual AM depth, and the displayed IF level is proportional to the average carrier level. The actual AM depth can be computed as the ratio of the two readings with the following formula:

$$AM \text{ in } \% = \frac{\text{demodulated ac}}{\text{average carrier level}} \times 100\% = \frac{\text{displayed AM}}{\text{displayed IF level}} \times 100\%$$

The Ratio feature can be used to simplify this calculation: First, measure the IF level, then press the AM key and enter the IF level on the numeric keys. Then press the RATIO key. AM is now displayed although the IF level is not optimum.

Guidelines for Measurements when AM ALC is Off.

In most circumstances, when the AM ALC is off (loop open), use IF levels greater than or equal to 100% for FM measurements and less than or equal to 100% for AM measurements.

Peak Tuned RF Level

FUNCTIONS

Special Function 36 (Peak Tuned RF Level)

DESCRIPTION

Another method the Measuring Receiver can use to measure level is Special Function 36. The average power measured in this case is actually the peak level of the down-converted RF input falling in the IF. The term "peak level" refers to the fact that a peak-responding IF detector is used to measure the signal level. The internal controller converts this level to average power and displays the result. (See the block diagram in "MEASUREMENT TECHNIQUE".) The Peak Tuned RF Level function is not calibrated, and so it is not as accurate or sensitive as the Tuned RF Level function (initiated with the TUNED RF LEVEL key) that must be specifically calibrated for each frequency. The Peak Tuned RF Level function enables the instrument to measure the level of frequencies that are drifting, or to determine flatness as a function of carrier frequency. This function is more sensitive than the RF Power or RF Level (Special Function 35) measurement modes.

PROCEDURE

To make a peak tuned RF level measurement, first tune the instrument to the input signal by selecting AUTOMATIC OPERATION. Key in 36.0 SPCL.

HP-IB PROGRAM CODES

LIN results = LN
LOG results = LG
SPCL = SP
VOLTS units = VL
mV units = MV
uV units = UV
WATTS units = WT

MEASUREMENT TECHNIQUE

When the Measuring Receiver is tuned, all the power falling within the IF bandpass filter is amplified and peak detected. The detected power is then measured by the voltmeter and displayed in the selected measurement units.

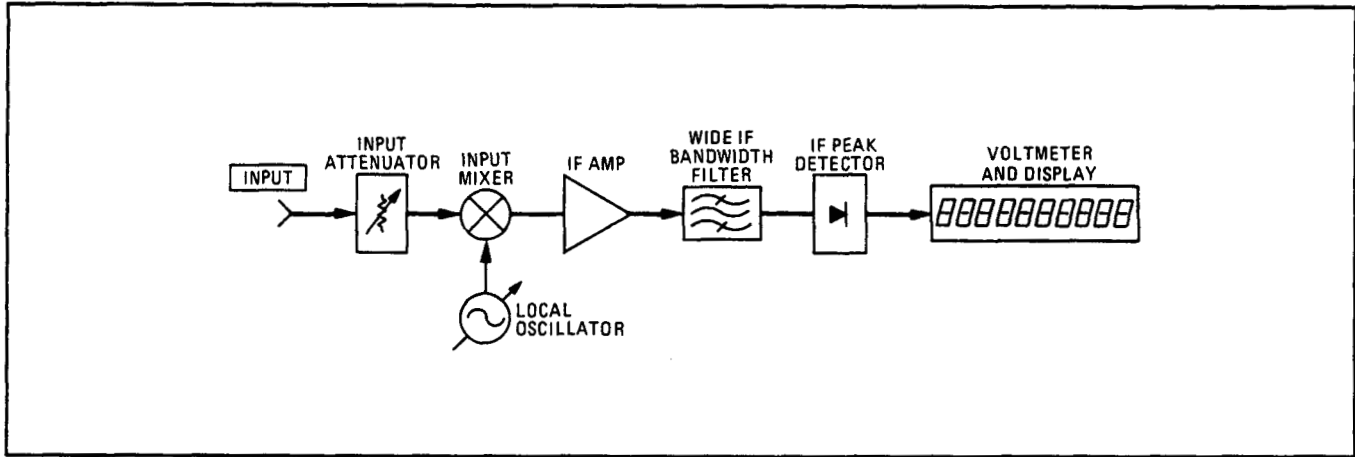

Peak Tuned RF Level Measurement Block Diagram

COMMENTS

Input/Output Status.

When the peak tuned RF level measurement is selected, MODULATION OUTPUT/AUDIO INPUT is blanked. AM OUTPUT and FM OUTPUT (rear panel) remain active during this measurement.

Relative Measurements.

If the peak tuned RF level is to be displayed relative to a reference, enter the value as a ratio reference using the RATIO key. (Refer to *Ratio* on page 3-245.)

Accurate Power Measurements.

Use an external power sensor to make accurate, absolute power measurements. (Refer to *RF Power* on page 3-75 or to *Tuned RF Level* on page 3-95.)

Attenuator Measurements

FUNCTIONS

SET REF, Special Function 26 (Set Reference)

DESCRIPTION

By setting a zero-reference at the current measurement level, the gain of linear devices (such as attenuators and amplifiers) can be measured directly and accurately. The current RF level then becomes the reference for all subsequent tuned RF level measurements made at that frequency.

Special Function 26 enables the Measuring Receiver to exit or to re-enter (using the previous reference) the Attenuator Measurement mode.

The SET REF key should be used instead of the RATIO key for relative power measurements. (The Ratio function is still available but with restrictions. Refer to "COMMENTS" for an elaboration of the restrictions.)

PROCEDURE

To make relative power measurements in the Attenuator Measurement mode, connect an RF signal through an RF cable (or sensor module) to the RF INPUT connector of the Measuring Receiver. Tune the RF source to the frequency of interest by selecting FREQ.

Select TUNED RF LEVEL (Shift, RF POWER) and wait for the measurement result to be displayed.

Select SET REF (Blue Key, ZERO) to set the initial reference for subsequent relative measurements. Select LOG/LIN to change the display to read in % or dB units. As the input level changes, the level relative to the initial reference is displayed.

As the input signal level approaches a maximum or minimum limit, the RF input circuits must re-range to accommodate the new level. If the input circuits are re-ranging for the first time at the signal frequency, the instrument must recalibrate. If RECAL is displayed, press the CALIBRATE key and hold the signal level steady until a valid measurement is displayed. If UNCAL is displayed, set the input signal to a level at which RECAL is displayed and press the CALIBRATE key. (Two input range-to-range calibration factors are stored for each of the two IF detectors. Refer to Tuned RF Level Calibration and Calibration Factors for a description of calibration factors and their derivation.)

Key in 26.0 SPCL or TUNED RF LEVEL to exit the Attenuator Measurement mode and re-enter the absolute Tuned RF Level mode. (Refer to Special Functions for a more specific selection procedure.)

Key in 26.1 SPCL to re-enter the Attenuator Measurement mode using the previous reference.

HP-IB PROGRAM CODES

CALIBRATE on = C1
LIN results = LN
LOG results = LG
SET REF = RF
SPCL = SP
TUNED RF LEVEL = S4

INDICATIONS

Selecting TUNED RF LEVEL might elicit all of the following responses:

Two dashes (--) indicate that the instrument is searching for the input signal but has not found it. This is the normal automatic tune mode.

Four dashes (----) indicate that the signal has been found and the instrument is awaiting a settled measurement.

Six dashes (-----) indicate that the instrument is fine tuning the IF synchronous detector's VCO to locate the signal in its narrow IF filter. (This indication is used only with the IF synchronous detector.)

When entering Tuned RF Level for the first time, the normal display sequence is: ----, -----, ----, then the measurement result.

If the signal level approaches a maximum or minimum limit of the RF input circuits and if the next input range has not been previously calibrated at that signal frequency, the RECAL annunciator lights to indicate the need for range calibration. Hold the signal level steady and select CALIBRATE.

If the signal level goes beyond a maximum or minimum limit of the RF input circuits, and it cannot be calibrated at that level, the UNCAL annunciator lights. Re-adjust the signal level until the UNCAL annunciator goes off and the RECAL annunciator lights, then hold the signal level steady and select CALIBRATE.

If both the UNCAL and RECAL annunciators are lighted, the instrument can still be calibrated, but the displayed reading is not yet calibrated.

The LED within the SET REF key (the ZERO key) will not light when pressed.

MEASUREMENT TECHNIQUE

The SET REF key sets the Measuring Receiver to make tuned RF level measurements relative to an initially-set reference. Measurement restrictions that apply are the same as for the normal Tuned RF Level measurement mode.

The major difference between absolute and relative tuned RF level measurements is the way the initial reference is obtained. For absolute measurements, the initial level measurement made with the IF detector is equated to a measurement made on the same signal with a power sensor (essentially the RF Power measurement). For relative measurements, the initial level measurement made with the IF detector is equated to 100%.

Since the relative measurement uses the same IF detectors and RF input ranges as the absolute measurement, the absolute and relative measurements share the calibration factors for the two internal RF input range changes. Thus relative level measurements can be made on signal levels ranging from 0 to -127 dBm. Also, when measurement modes are switched between relative and absolute, the only recalibration necessary is for the initial reference.

(Refer to *Tuned RF Level* on page 3-95 for a more detailed description of all aspects of tuned RF level measurement technique.

COMMENTS

Input/Output Status

Accurate level measurements can be made only on cw signals. The MODULATION OUTPUT/AUDIO INPUT is blanked during tuned RF level measurements.

Measurement Limits

Relative measurements cannot be made on RF signals with absolute levels outside the range 0 to -127 dBm.

Valid Measurements Can Only Be Made on Tuned Signals

The Measuring Receiver must be tuned to the input frequency before valid tuned RF level measurements can be made. The instrument can be manually tuned to the frequency of interest either before or after the TUNED RF LEVEL Key is pressed. (Refer to *RF Frequency Tuning* on page 3-141.)

If the tuned frequency moves more than ± 5 kHz from the frequency at which the power sensor reference was taken, the instrument must be retuned.

Using Ratio with Tuned RF Level Measurements

For most measurement modes, when the Ratio feature is used, a known reference is first established either by keying in the desired reference or by using the displayed measurement as the reference. Furthermore, the established reference can always be recalled (using PREVIOUS RATIO or Special Function 11.2). In the Attenuator Measurement mode the initial SET REF reference cannot be recalled.

Also, when using the Ratio feature with Tuned RF Level, the input RF range recalibration data is ignored.

CAUTION

Do not use 31.1 SPCL when making any uncalibrated, or relative signal level measurement in Tuned RF Level mode without a power sensor. The Sensor Module must be used when making Tuned RF Level range-to-range calibrations with the AVG Detector.

Selective Power Measurements (Option 030)

FUNCTIONS

Special Functions 23 (External LO) and 24 (Selective Power Measurements)

DESCRIPTION

The Series 030, Selective Power Measurement Options enable the Measuring Receiver to measure adjacent-channel power and single-sideband noise on continuous wave (CW) RF signals.¹ Both measurements basically consist of tuning the instrument to the RF signal, measuring the IF level in the passband of a selected IF filter, then offsetting the signal onto the skirt of the IF filter and re-measuring the IF level. Offsetting the signal places a portion of the sideband noise of the carrier in the passband of the IF filter. The ratio of the out-of-band IF level to the in-band IF level is the desired measurement result (expressed in dB).

The measurement procedure requires that the operator step through a sequence of special functions and increment either the local oscillator (LO) or the signal source. For RF signal frequencies above 300 MHz, an external LO is recommended for greatest sensitivity and accuracy. Special Function 23 switches the LO between internal and external. The external LO connects to a rear-panel connector. (Since Option Series 030 provide rear-panel LO input and output connectors, Option 003 is not available in conjunction with the 030 Series Options.)

The 030 Series Options include the choice of two IF bandpass filters installed. The bandwidths of these IF filters match the requirements of specific industry standards for measuring adjacent-channel power. The following table lists the optional filters and their bandwidths.

Filters	Options
12.5 kHz Adjacent Channel Filter	Option 032
25 kHz Adjacent Channel Filter	Option 033
30 kHz (Cellular Radio) Filter	Option 035
Carrier Noise Filter	Option 037

All selective power measurements consist of three processes. The first two are identical for either adjacent channel power or single-sideband noise measurements. However, the third step is different depending on the measurement being made:

1. Setting up the LO:

Put the Measuring Receiver in its selective power measurement mode. If using an external LO, enter an LO value into the Measuring Receiver that is offset 455 kHz from the incoming signal. If using the Measuring Receiver's internal LO, just tune to the input signal.

2. Setting the reference:

Measure the voltage reference and set that reference to be 0 dB. (Adjust the LO frequency to ensure that the peak value is being measured.) Then measure the peak voltage reference and set it to be 0 dB.

3a. Measuring the adjacent channel power:

Tune the LO to the 6 dB point of the filter and move the LO the spacing required for the appropriate adjacent channel filter.

3b. Measuring the single-sideband noise:

Choose whether to display the data as total power in the 2.5 kHz filter bandwidth or as dBc in a 1 Hz bandwidth. Tune the Measuring Receiver (or the external LO) to the offset frequency desired and measure the noise.

¹This option can be retrofitted to instruments with serial-number prefixes 2535A and above. For retrofit information, contact the nearest HP sales office.

PROCEDURE

The following procedures are examples of typical measurement applications. These procedures describe the steps for measuring adjacent-channel power and single-sideband noise.

ADJACENT CHANNEL POWER MEASUREMENTS

Two procedures are available. The first procedure measures the lower adjacent channel power. The second procedure measures the upper adjacent channel power.

To Measure the Lower Adjacent Channel Power

Setting Up the LO

1. Tune to the input frequency. (Selecting the **FREQ** key automatically tunes the Measuring Receiver to the input frequency. Keying in the input frequency value (in MHz) followed by the **MHz** key manually tunes the Measuring Receiver to the frequency value keyed in. For more information about tuning, refer to *RF Frequency Tuning* on page 3-141.)
2. Press the **MHz** key to manually tune and center the IF.
3. Select **24.0 SPCL** to enter the Selective Power Measurement mode.
4. Select whether an external LO or the Measuring Receiver's internal LO will be used. If the internal LO will be used, go to step 7. If an external LO will be used, connect the LO signal source to the **LO INPUT** connector on the rear panel of the Measuring Receiver. (More information about the **LO INPUT** is available in *LO Input and LO Output* on page 3-155.)
5. Set the external LO source frequency to 455 kHz greater than the input frequency, and its amplitude to 0 dBm.
6. Key in **23.1 SPCL** to set the LO to external.

Setting the Reference

7. Select **24.1 SPCL** to establish the IF reference value (in volts).
8. Select **24.2 SPCL** to set the reference to 0 dB.
9. Adjust the LO frequency until the maximum value is displayed. The Measuring Receiver's automatic tuning capability measures an IF value close to the peak, but the internal circuitry does not specifically check for a peak. This step enables you to fine tune to the peak of the signal.
 - a. If using an external LO, step the LO frequency in small increments until the peak value is measured.
 - b. If using the internal LO, set the desired increment value (in kHz) and step the LO using the \uparrow kHz and \downarrow kHz keys until the maximum value is displayed. (It is possible to tune the input signal instead of the LO. Refer to *Comments, "Frequency Offsetting"* on page 3-127.)
10. Reselect **24.1 SPCL** to establish the IF reference value (since that value has now been peaked).
11. Reselect **24.2 SPCL** to set the reference to 0 dB.

Measuring the Lower Adjacent Channel Power

12. Decrease the LO frequency value until -6 dB is displayed. Note the frequency difference between the source and the LO. This frequency difference is relative to the 6 dB corner of the IF bandpass filter. (Once the 6 dB corner frequency has been determined, the corner need not be remeasured when new measurements are made with that filter.)

13. Decrease the LO frequency by an offset of either 8.25 kHz, 13 kHz, or 17 kHz depending on the adjacent channel being measured (refer to the table below).

Channel Spacing in kHz	Displacement of the 6 dB Point per CEPT (in kHz)
12.5 kHz	8.25 kHz
20 kHz	13 kHz
25 kHz	17 kHz

14. The value displayed is the adjacent channel power measurement result.

To Measure the Upper Adjacent Channel Power

Setting Up the LO

1. Tune to the input frequency. (Selecting the FREQ key automatically tunes the Measuring Receiver to the input frequency. Keying in the input frequency value (in MHz) followed by the MHz key manually tunes the Measuring Receiver to the frequency value keyed in. For more information about tuning, refer to *RF Frequency Tuning* on page 3-141.)
2. Press the MHz key to manually tune and center the IF.
3. Select 24.0 SPCL to enter the Selective Power Measurement mode.
4. Select whether an external LO or the Measuring Receiver's internal LO will be used. If the internal LO will be used, go to step 7. If an external LO will be used, connect the LO signal source to the LO INPUT connector on the rear panel of the Measuring Receiver. (More information about the LO INPUT is available in *LO Input and LO Output* on page 3-155.)
5. Set the external LO source frequency to 455 kHz less than than the input frequency, and it's amplitude to 0 dBm.
 - a. If using the internal LO, on the Measuring Receiver select 910 \downarrow kHz. This tunes the Measuring Receiver to the image frequency of the LO. At this time, the RF frequency display will not match the input frequency value.
6. Key in 23.1 SPCL to set the LO to external.

Setting the Reference

7. Select 24.1 SPCL to establish the IF reference value (in volts).
8. Select 24.2 SPCL to set the reference to 0 dB.
9. Adjust the LO frequency until the maximum value is displayed. The Measuring Receiver's automatic tuning capability measures an IF value close to the peak, but the internal circuitry does not specifically check for a peak. This step enables you to fine tune to the peak of the signal.
 - a. If using an external LO, step the LO frequency in small increments until the peak value is measured.
 - b. If using the internal LO, set the desired increment value (in kHz) and step the LO using the \uparrow kHz and \downarrow kHz keys until the maximum value is displayed. (It is possible to tune the input signal instead of the LO. Refer to *Comments, "Frequency Offsetting"* on page 3-127.)
10. Reselect 24.1 SPCL to establish the IF reference value (since that value has now been peaked).
11. Reselect 24.2 SPCL to set the reference to 0 dB.

Measuring the Upper Adjacent Channel Power

12. Increase the LO frequency value until -6 dB is displayed. Note the frequency difference between the source and the LO. This frequency difference is relative to the 6 dB corner of the IF bandpass filter. (Once the 6 dB corner frequency has been determined, the corner need not be remeasured when new measurements are made with that filter.)
13. Increase the LO frequency by an offset of either 8.25 kHz, 13 kHz or 17 kHz depending on the adjacent channel being measured (refer to the table below).

Channel Spacing in kHz	Displacement of the 6 dB Point per CEPT (in kHz)
12.5 kHz	8.25 kHz
20 kHz	13 kHz
25 kHz	17 kHz

14. The value displayed is the adjacent channel power measurement result.

SINGLE-SIDEBAND NOISE MEASUREMENTS

Use this procedure only when Option 037 has been installed.

Setting Up the LO

1. Tune to the input frequency. (Selecting the FREQ key automatically tunes the Measuring Receiver to the input frequency. Keying in the input frequency value (in MHz) followed by the MHz key manually tunes the Measuring Receiver to the frequency value keyed in. For more information about tuning, refer to *RF Frequency Tuning* on page 3-141.)
2. Press the MHz key to manually tune and center the IF.
3. Select 24.0 SPCL to enter the Selective Power Measurement mode.
4. Select whether an external LO or the Measuring Receiver's internal LO will be used. If the internal LO will be used, go to step 7. If an external LO will be used, connect the LO signal source to the LO INPUT connector on the rear panel of the Measuring Receiver. (More information about the LO INPUT is available in *LO Input and LO Output* on page 3-155.)
5. Set the external LO source frequency to 455 kHz greater than the input frequency, and its amplitude to 0 dBm.
6. Key in 23.1 SPCL to set the LO to external.

Setting the Reference

7. Select 24.5 SPCL to establish the IF reference value (in volts).
8. Select 24.6 SPCL to set the reference to 0 dB.
9. Adjust the LO frequency until the maximum value is displayed. The Measuring Receiver's automatic tuning capability measures an IF value close to the peak, but the internal circuitry does not specifically check for a peak. This step enables you to fine tune to the peak of the signal.
 - a. If using an external LO, step the LO frequency in small increments until the peak value is measured.
 - b. If using the internal LO, set the desired increment value (in kHz) and step the LO using the \uparrow kHz and \downarrow kHz keys until the maximum value is displayed. (It is possible to tune the input signal instead of the LO. Refer to *Comments*, "Frequency Offsetting" on page 3-127.)
10. Reselect 24.5 SPCL to establish the IF reference value (since that value has now been peaked).
11. Reselect 24.6 SPCL to set the reference to 0 dB.

Making the Single-Sideband Noise Measurement

11. If you want the measurement to be displayed as total power in the 2.5 kHz bandwidth, go to the next step. If you want the measurement to be normalized to 1 Hz, select 24.7 SPCL.
12. Adjust the LO frequency by the desired offset to display the noise value. The value displayed is the single-sideband noise measurement result.

Additional Special Functions for Single-Sideband Noise

These special functions enable you to change and display the noise measurement bandwidth. The noise measurement bandwidth is measured and entered at the factory and probably does not need to be remeasured unless operating conditions for the Measuring Receiver change radically.

1. **Special Function 24.8** Changes the noise measurement bandwidth used in single-sideband noise measurements. The value entered (in units of MHz) must be between 100 Hz and 20 kHz (0.0001 and 0.02 MHz). To enter a noise measurement bandwidth key in 24.8 SPCL then key in the bandwidth expressed in MHz and press the MHz key. This factor is stored in non-volatile memory. Determination of the noise measurement bandwidth is usually done by numerical integration of the IF filter response.
2. **Special Function 24.9** Displays the value of the noise measurement bandwidth used in conjunction with Special Function 24.7. The displayed value times out after a few seconds.

Summary of Special Functions 23 and 24

SPCL	Special Function Description	Comments
23.0	Sets the LO to internal.	
23.1	Sets the LO to external.	
23.2	Displays the status of the LO: (0=Internal, 1=External).	The display times out after a few seconds.
24.0	Sets the Measuring Receiver to the Selective Power Measurement Mode.	This special function must be selected before any selective power measurements can be made.
24.1	Selects the wide-bandwidth IF filter for adjacent-channel or cellular radio power measurements. Displays the IF level (in volts).	Used with 24.2 SPCL. The bandwidth of the IF is determined by the Option Series 030 Filter installed.
24.2	Establishes the level measured with 24.1 SPCL as the 0 dB reference.	
24.3	Selects a narrower bandwidth IF filter than 24.1 SPCL for adjacent channel power measurements. Displays the IF level (in volts).	Used with 24.4 SPCL.
24.4	Establishes the level measured with 24.3 SPCL as the 0 dB reference.	
24.5	Selects a very narrow bandwidth IF filter (2.5 kHz) for the single-sideband noise measurement. Displays the IF level (in volts).	Used with 24.6 SPCL. Can only be used with Option 037.
24.6	Establishes the level measured with 24.5 SPCL as the 0 dB reference.	Can only be used with Option 037.
24.7	Displays the noise measurement as normalized to a 1 Hz bandwidth.	Can only be used with Option 037.
24.8	Enables setting of the value of the noise measurement bandwidth.	Can only be used with Option 037.
24.9	Displays the value of the noise measurement bandwidth.	Can only be used with Option 037.

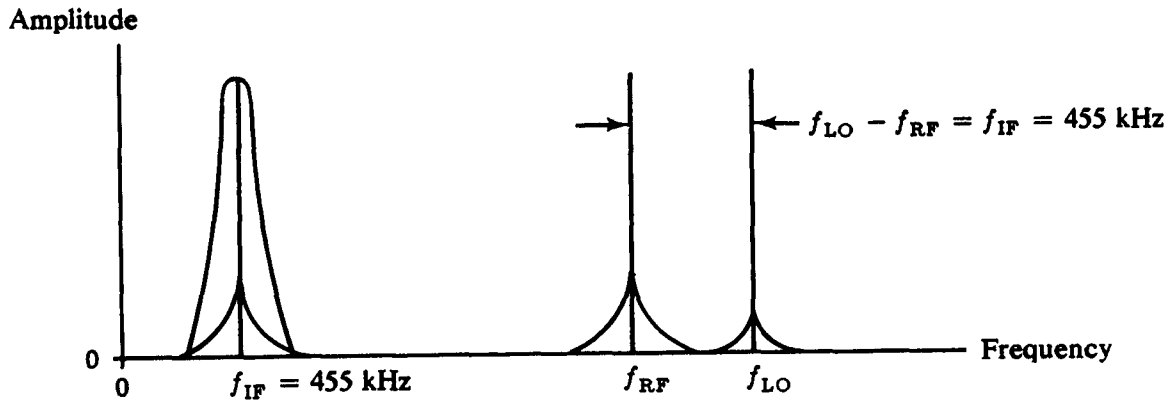

(a.) No Frequency Offset

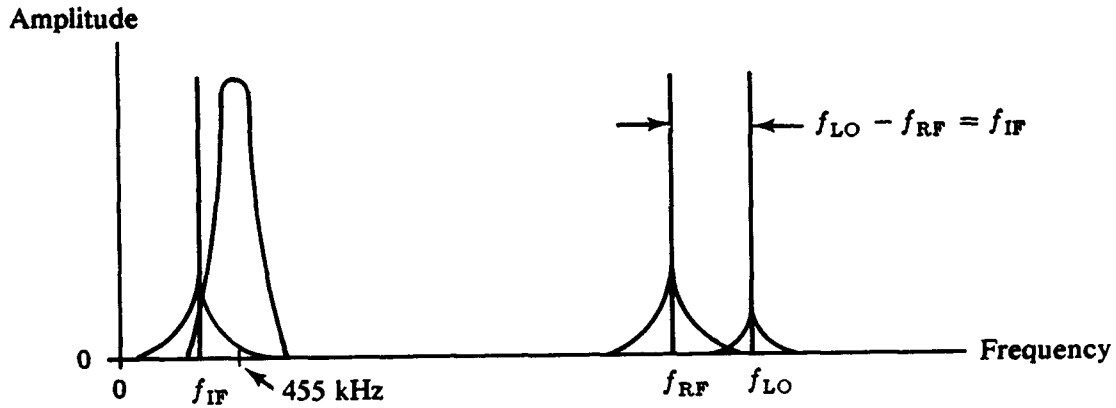

(b.) Frequency Offset by Increasing RF Signal Frequency

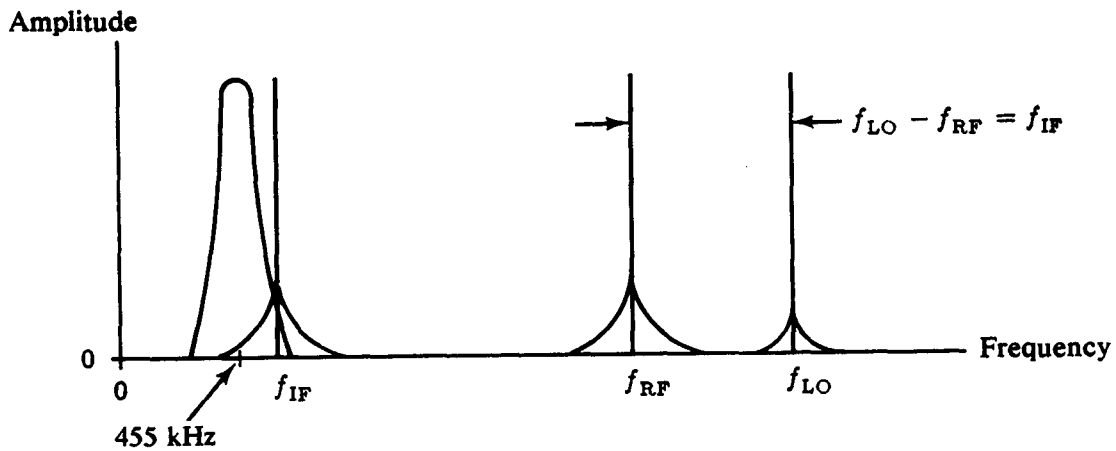

(c.) Frequency Offset by Increasing LO Frequency

Signal Tuning Illustrating Frequency Offsetting

MEASUREMENT TECHNIQUE

The Series 030 Options add more IF signal processing circuitry to the Measuring Receiver including programmable IF amplifiers and filters and a true rms IF detector. (Refer to the Selective Power Measurement Option simplified block diagram.)

Initializing.

The Measuring Receiver must be set up for the first part of the measurement which establishes the IF reference level. This is most easily done by keying in Special Function 24.0 which:

- holds the RF input attenuation;
- sets the IF to 455 kHz, retunes the LO to accommodate the 455 kHz IF, and sets the LO to the manual-tune, low-noise mode;
- inserts the RF Input High-Pass Filter (which limits the lowest RF input frequency to 10 MHz but filters any low-frequency RF input signals from interfering with the measurement); and
- disables Error Messages 01 through 04.

The Measurement Sequence.

The first step in the measurement sequence is to tune to LO to the RF input signal to center the IF in the IF filter passband. Refer to (a.) in the previous figure "Signal Tuning Illustrating Frequency Offsetting". After the instrument is properly tuned the IF (in-band) level is measured with the IF RMS Detector. The in-band IF level is defined as a ratio reference.

Next the frequency is offset either by tuning the RF input signal (if this is possible) or by tuning the LO as illustrated in (b.) and (c.) of the same figure. Note that tuning is in opposite directions. If it is desired to offset the IF to the upper skirt of the IF filter, the RF frequency must be decreased or the LO frequency increased.

After the signal is offset, a second (out-of-band) IF level measurement is made with the same IF RMS Detector. Since the IF level has decreased considerably, the IF gain is adjusted to bring the IF level within the optimum range of the IF RMS Detector. The ratio of the out-of-band IF level to the in-band level is computed and displayed. Out-of-band IF signal appears in the IF passband because of

- sideband noise on the RF input signal,
- modulation sidebands on the RF input signal (if the signal is modulated),
- sideband noise on the LO, and
- the limited signal rejection in the stopband of the IF bandpass filter.

Since it is desired to measure only the first two contributions (that is, the contributions of only the RF input signal), care must be taken to choose the correct frequency offset, the proper LO, and the proper IF filter.

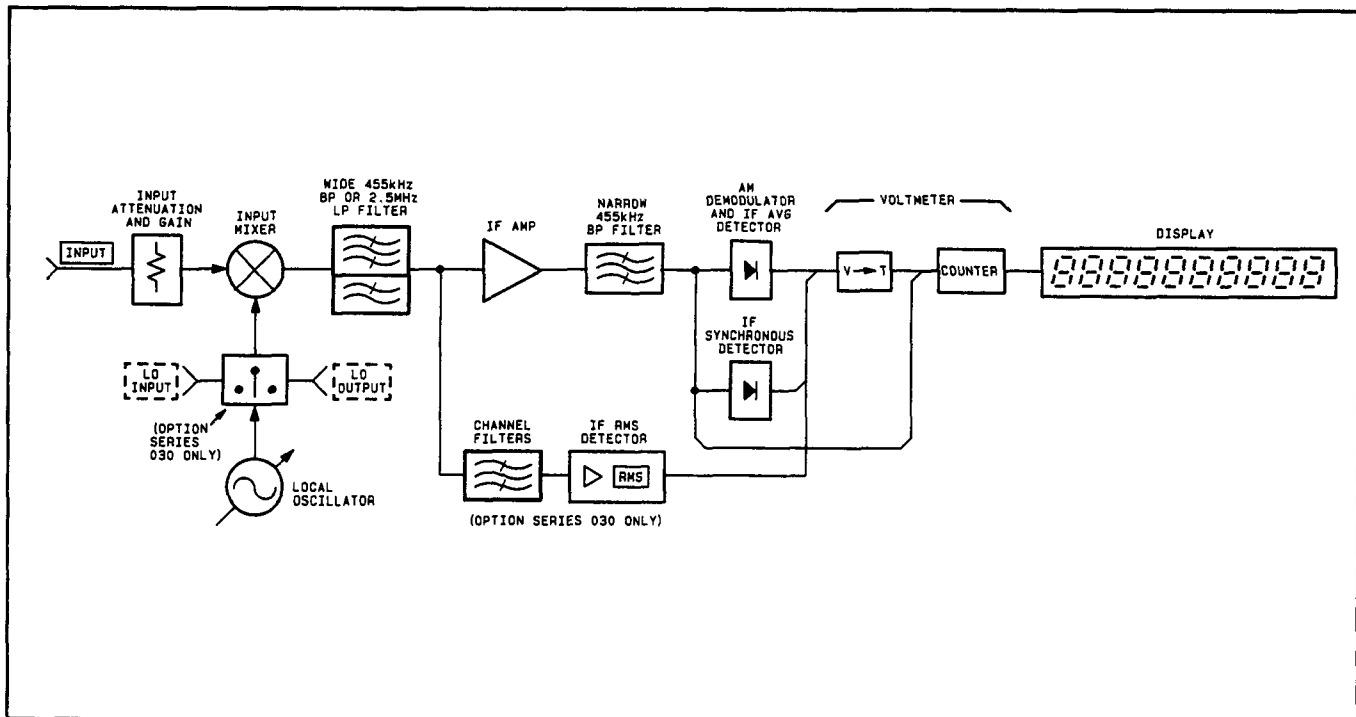

Selective Power Measurement Simplified Block Diagram

COMMENTS

Frequency Modes Possible During the Selective Power Measurement.

During the selective power measurement, the instrument must be properly tuned to the signal and must be in one of the following RF Frequency measurement modes:

- RF Frequency (the **FREQ** key, HP-IB Code: M5),
- RF Frequency Error (the **S**, **FREQ ERROR** keys, HP-IB Code: S5),
- IF Frequency (Special Function 34, HP-IB Code: 34.0SP), or
- LO Frequency (Special Function 33, HP-IB Code: 33.0SP).

When To Use an External LO.

A low-noise, external LO is recommended for RF input frequencies above 300 MHz. Also, an external LO can be selected for lower phase noise and finer resolution in its frequency steps.

When an external LO is used, the internal LO should be manually tuned to an arbitrary frequency (such as 100 MHz) to defeat automatic signal search. Refer to *RF Frequency Tuning* on page 3-141 for tuning information. (Note that the 455 kHz IF will be used.)

Frequency Offsetting.

The IF frequency can be offset by one of the following three methods:

- offsetting the RF input signal.
- offsetting the external LO, or
- offsetting the internal LO using the \uparrow kHz or \downarrow kHz keys.

An increase in the RF input signal moves the IF signal down the lower skirt of the IF bandpass filter. An increase in the LO frequency (either external or internal) moves the IF signal down the upper skirt. Refer to *Measurement Technique* on page 3-125 for an illustration of this.

The measurement specification may require that the frequency offset be made from the 6 dB corner frequency of the IF bandpass filter.

Finding the IF Peak.

For maximum accuracy, the frequency offset should be relative to the frequency at which the IF signal is peaked in the IF bandpass filter. (IF filter ripple can be as high as 2 dB.) Automatic tuning brings the IF close to the peak, but the instrument controller does not specifically check for an IF peak. Finding the IF peak is most easily accomplished by tuning the RF input signal (if this is possible) or by tuning the external LO while Special Function 24.1, 24.3, or 24.5 is active. The RF input signal or external LO is tuned until the displayed IF voltage is at its peak. Finding the IF peak by incrementing the internal LO is similar, but the active special function must be re-entered after each frequency increment. Tuning requires a range of only a few kHz.

In all the measurements, you can tune the input signal instead of the LO. This is the easiest way if the source is tuneable. However, you must tune the source opposite to the direction you would tune the LO. For example, if you tune the LO down, you would tune the source up in frequency.

IF Output

CAUTION

Do not apply greater than 40 Vdc or greater than +15 dBm into the rear-panel IF OUTPUT connector.

DESCRIPTION

The rear-panel IF OUTPUT (a female BNC connector) provides a buffered output to enable monitoring of the Measuring Receiver's IF signal. The ac-coupled signal ranges from 150 kHz to 2.5 MHz and normally varies in level from -27 to -3 dBm (into 50 ohms). The level variation depends on the RF input signal level, RF input attenuation or gain setting, and the measurement selected.

The 3 dB bandwidth of the signal at IF OUTPUT is approximately 3 MHz when the instrument uses the wide, 2.5 MHz low-pass filter; approximately 200 kHz when the instrument uses the wide, 455 kHz bandpass filter; and approximately 30 kHz when the instrument uses the narrow, 455 kHz bandpass filter.

At any particular input level and front-panel setting, the flatness of the IF OUTPUT, as input frequency varies, is typically within $\pm 5\%$.

BLOCK DIAGRAM

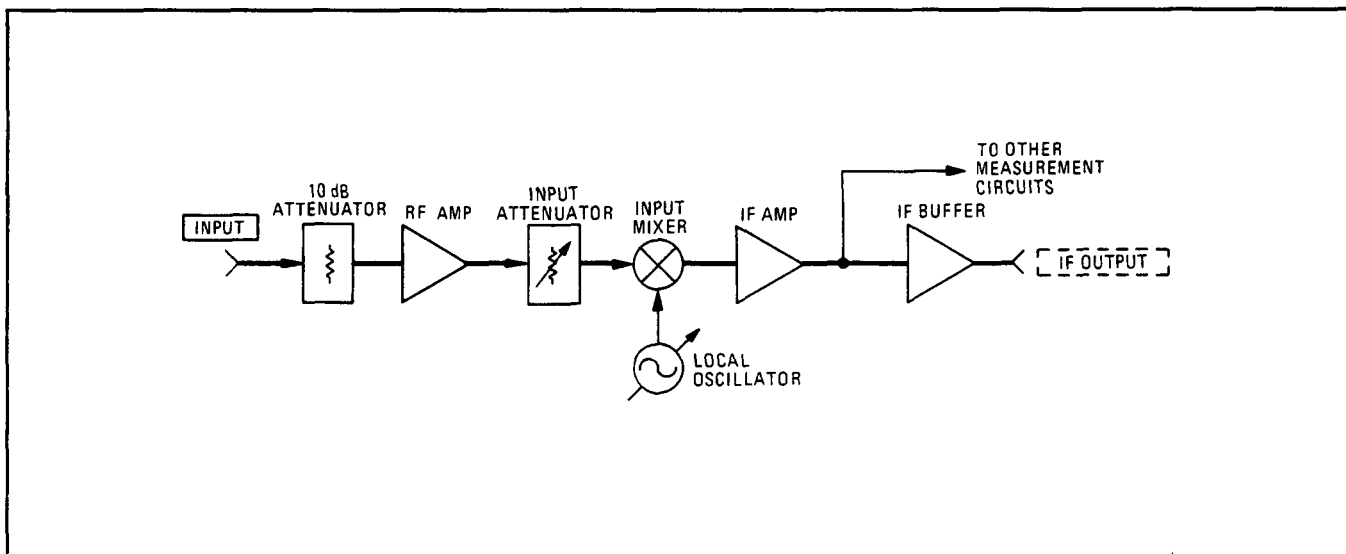

IF Output Block Diagram

COMMENTS**Use the Measuring Receiver as a Down Converter.**

The Measuring Receiver can be used as a high-quality, automatically tuneable, down-converter. Use the IF OUTPUT as the down-converter's output.

Adjacent Spurious Signals.

Check for close-in spurious signals on the RF input by connecting a spectrum analyzer to IF OUTPUT.

When connecting instruments such as counters to the IF OUTPUT, check that they do not inject spurious signals into the IF path. Spurious signals in the Measuring Receiver's IF may generate measurement error.

External Attenuation (dB)

FUNCTIONS

dB EXT ATTEN, Special Function 25 (External Attenuation dB)

DESCRIPTION

Level measurements can be scaled to correctly indicate the power at the input of an external attenuator or amplifier connected to the instrument.

Special Function 25.2 causes display of the value of the selected external dB attenuation or gain.

PROCEDURE

To enter external attenuation:

1. Select the keys corresponding to the magnitude of external attenuation or gain expressed in dB.
2. If the offset is gain rather than attenuation, designate the value as negative by selecting the Blue Key and minus-sign (-) key (the decimal key). No sign indication is necessary for entering attenuation.
3. Select dB EXT ATTEN (Blue Key, LOG/LIN).

To display the current offset in dB, key in 25.2 SPCL.

To exit external attenuation, select dB EXT ATTEN again.

To re-enter external attenuation, select dB EXT ATTEN again.

EXAMPLE

To account for an external 10 dB amplifier connected to the instrument:

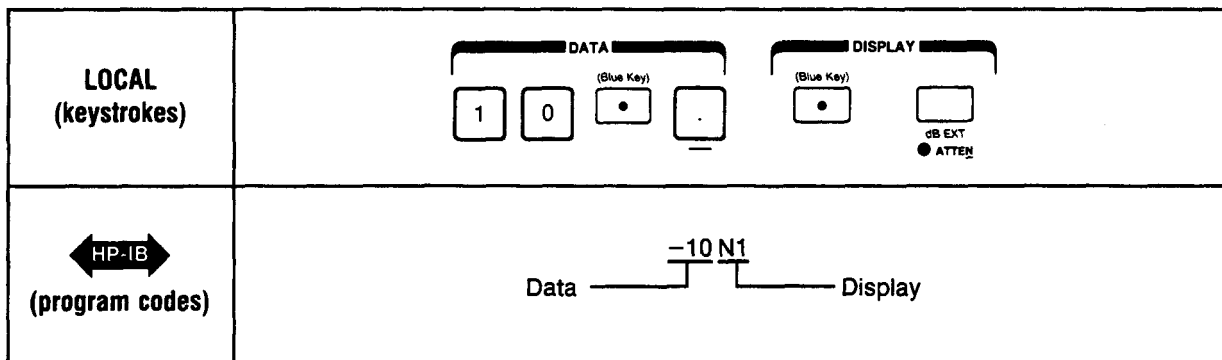

HP-IB PROGRAM CODES

dB EXT ATTEN off = N0

dB EXT ATTEN on = N1

SPCL = SP

When the dB EXT ATTEN key is pressed, the Measuring Receiver displays subsequent level measurements using the entered dB offset.

COMMENTS**Input/Output Status.**

MODULATION OUTPUT/AUDIO INPUT is blanked during most level measurements.

External Attenuation Value is Stored Through Other Measurement Selection.

If another Measurement mode is selected while the external attenuation function is enabled and a level Measurement mode is re-entered, the instrument automatically re-enters the external attenuation mode with the previous offset.

Remote Control RF Switch

DESCRIPTION

A compatible, external power sensor is required for making accurate, absolute RF power or tuned RF level measurements. The Measuring Receiver can be used with the following sensor configurations:

- A power sensor selected from the HP 8480 series sensors.
- A sensor module (such as the HP 11722A) that contains a power sensor, an RF switch, and an RF coaxial cable. The Measuring Receiver controls the RF switch in the sensor module to automatically switch the RF input signal between the RF INPUT of the Measuring Receiver and the power sensor as measurements require.
- A sensor module, built by the user, that includes a power sensor (from the HP 8480 series sensors), an RF cable, and an RF switch (such as the HP 33311 series or the HP 8761A). The rear-panel REMOTE CONTROL RF SWITCH outputs enable the Measuring Receiver to automatically switch the RF input signal between the RF input of the Measuring Receiver and the power sensor as measurements require.

NOTE

An HP 478A is a standard sensor but is not compatible with the Measuring Receiver.

For relative power measurements, no sensor is needed.

PROCEDURE

The following procedure provides a few guidelines for setting up and operating a remotely controlled sensor module.

Connect the RF switch, power sensor, RF cable, and Measuring Receiver as shown in the BLOCK DIAGRAM. Do not connect a sensor module (such as the HP 11722A) to the SENSOR input if the rear-panel remote control switches are to be used with a user-built sensor module. The control lines are in parallel, and the internal switch drive circuits cannot drive both.

The remote outputs are capable of driving both 5V and 12V to 15V switch solenoids. The solenoids should be of a latching type, but they need not have automatic drive disconnect. Examples of compatible RF switches are the HP33311B, Option 011 (5V solenoid) or the HP 8761A (12V to 15V solenoid).

Proceed with selected measurements. This user-built module will enable the Measuring Receiver to automatically switch between its inputs as measurements require.

BLOCK DIAGRAM

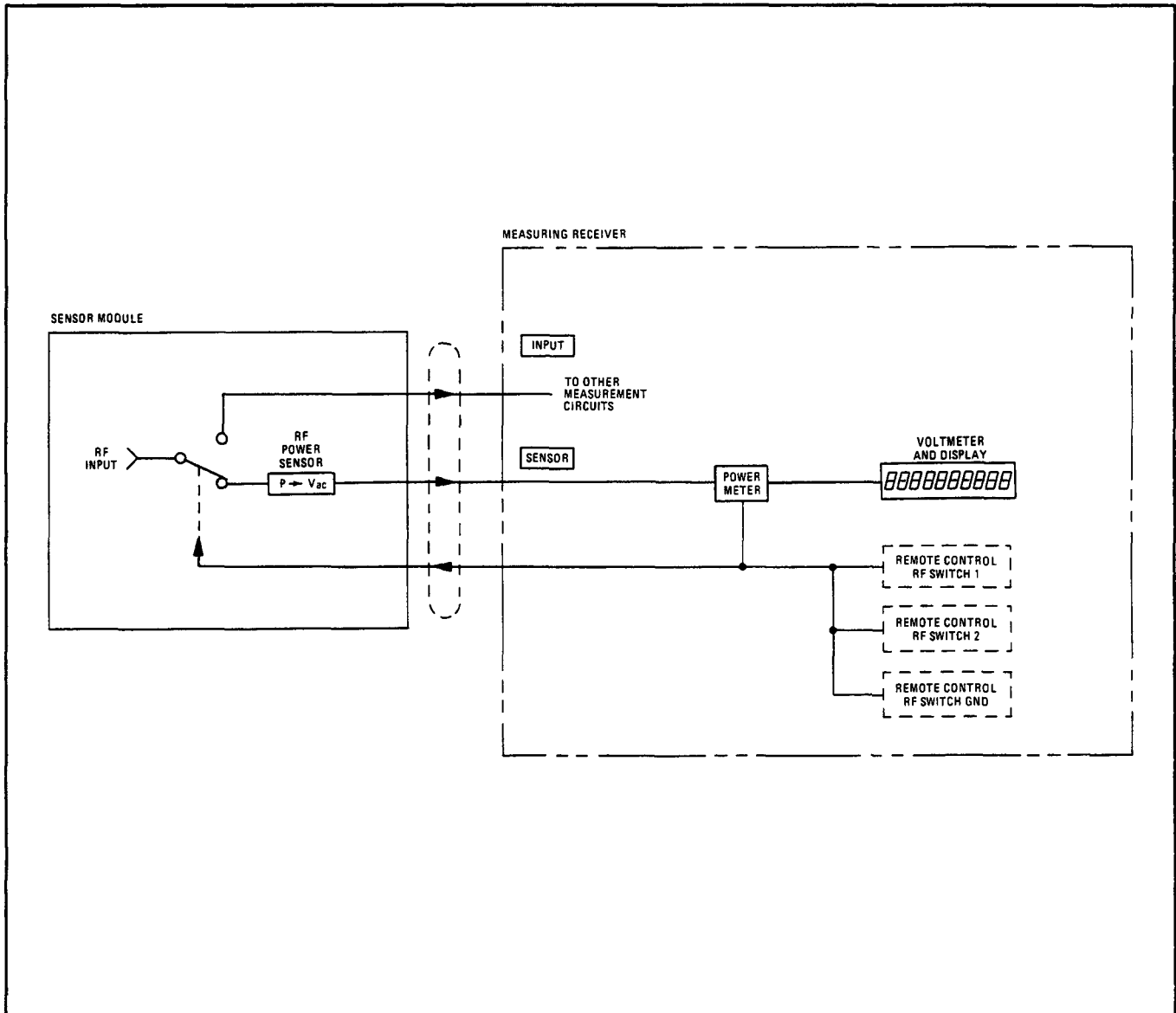

Block Diagram of Remote Control RF Switch

COMMENTS

REMOTE CONTROL Outputs are Exclusive to Compatible Switches.

The rear-panel REMOTE CONTROL outputs are not intended as general-purpose switch drives. The output should only be used with compatible RF switches.

Frequency Measurements (RF, LO, IF) Contents

RF INPUT FREQUENCY MEASUREMENTS

RF Input Frequency	3-137
<ul style="list-style-type: none"> • How to measure the frequency of the RF input signal. 	
RF Frequency Tuning	3-141
<ul style="list-style-type: none"> • How to select the different automatic and manual tune modes. 	
RF Frequency Error	3-147
<ul style="list-style-type: none"> • How to measure the difference between the input frequency and the frequency to which the instrument is tuned. 	

IF FREQUENCY

IF Frequency	3-151
<ul style="list-style-type: none"> • How to measure the instrument's IF frequency (the down-converted RF input signal). 	

LO FREQUENCY

LO Frequency	3-153
<ul style="list-style-type: none"> • How to measure the instrument's local oscillator (LO) frequency. 	
LO Input and LO Output	3-155
<ul style="list-style-type: none"> • How to provide an input for an external LO. • How to provide an output for the internal LO. 	

GENERAL FREQUENCY MEASUREMENT FUNCTIONS

RF Frequency Resolution	3-157
<ul style="list-style-type: none"> • How to manually set the display resolution (except audio frequency). 	

RF Input Frequency

FUNCTIONS

FREQ

DESCRIPTION

The Measuring Receiver can measure RF input signals from 150 kHz to 1300 MHz. (Higher frequencies can be measured using an external mixer as described in *Frequency Offset Control* on page 3-255 .)

To count input frequencies between 2.5 and 1300 MHz, the Measuring Receiver uses heterodyning; to count input frequencies from 150 kHz to 2.5 MHz, it counts the input directly.

In most circumstances, when using manual tuning and when the approximate frequency is known, the instrument can count signals with power levels less than -60 dBm. When used in conjunction with Tuned RF Level, the range can be extended below -100 dBm.

PROCEDURE

To make an input frequency measurement, first tune the instrument to the input signal (select AUTOMATIC OPERATION or refer to *RF Frequency Tuning* on page 3-141 to learn about more ways to tune the Measuring Receiver.) Select FREQ.

Manual tuning will be necessary when measuring low-level signals (inputs less than -25 dBm from 150 kHz to 650 MHz or less than -20 dBm from 650 to 1300 MHz).

HP-IB PROGRAM CODE

FREQ = M5

MEASUREMENT TECHNIQUE

For input frequencies between 2.5 and 1300 MHz, the Measuring Receiver tunes its local oscillator (LO) to the signal and down-converts it to an intermediate frequency (IF). The IF signal is amplified, limited, and counted. The LO frequency is also counted. The IF is subtracted from the LO frequency and the result is displayed.

For input frequencies below 2.5 MHz the RF input signal passes directly into the IF without down-conversion. The IF is counted and displayed.

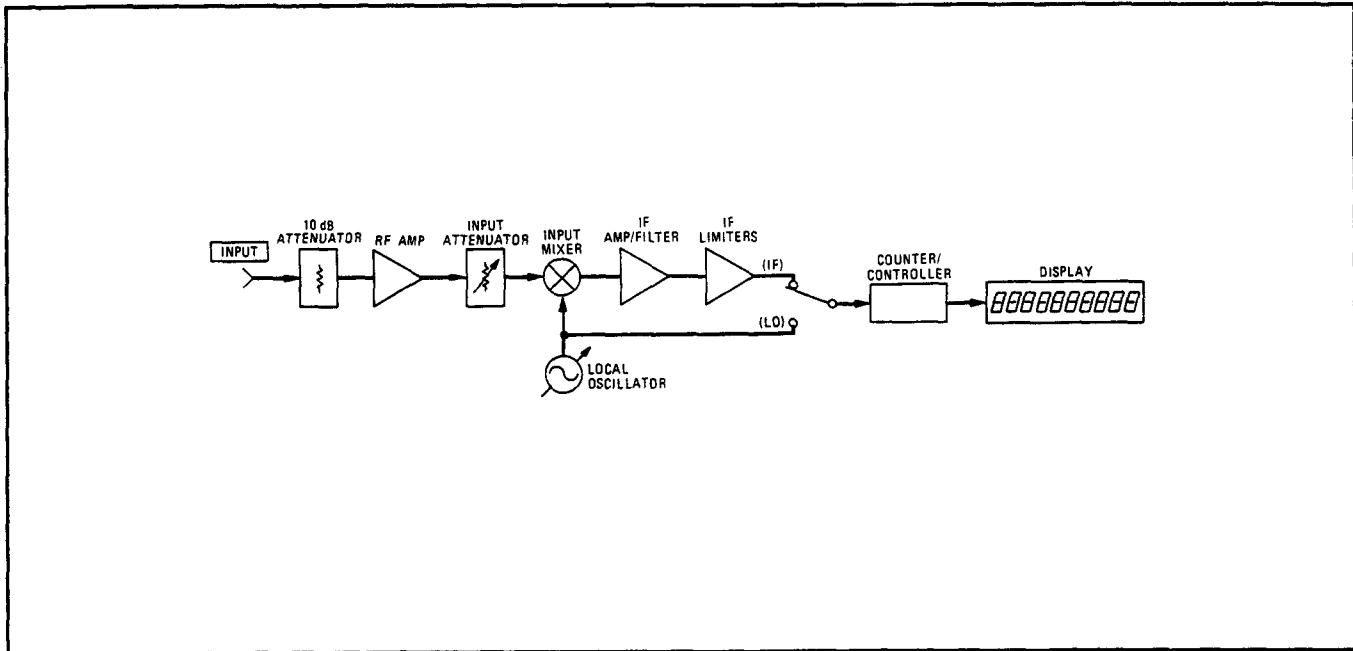

RF Input Frequency Measurement Block Diagram

COMMENTS

Input/Output Status.

When the instrument is measuring input frequency, the output signal at MODULATION OUTPUT/AUDIO INPUT represents the last modulation measurement made as indicated by the MODULATION OUTPUT annunciator.

Relative Measurements.

If RF frequency is to be displayed relative to a reference, enter the value as a ratio reference using the RATIO key. (Refer to *Ratio* on page 3-243.)

Increasing Measurement Sensitivity.

The RF Amplifier can be inserted (using Special Function 1) to increase the Measuring Receiver's sensitivity when the input signal level is less than -25 dBm. (Refer to *RF Input Attenuation and Gain* on page 3-265.)

Limiting Low-Level Signal Measurements.

When the Error Message Disable Control special function is in the automatic selection mode (Special Function 8.0), very low-level signals can be counted without generating error messages (Error 03 for example). However, other Special Function 8 codes enable error messages at much higher signal levels. (Refer to *Error Message Disable Control* on page 3-267.)

Centering the IF Does Not Affect Frequency Measurements.

It is important to note that when FREQ is selected, the IF need not be exactly centered to make valid frequency measurements. A frequency is displayed as long as a signal is present in the IF. Using the kHz (up arrow) or kHz (down arrow) functions will not change the displayed input frequency

even though tuning has been altered. If desired, the frequency error function can be used to indicate tuning error if desired.

Frequency Agile Sources.

For best results, use the manual-tune mode when working with frequency agile sources. With agile frequency sources (such as frequency synthesizers), it is possible for the carrier or its harmonics to hop unexpectedly into the IF passband either directly (for frequencies below 2.5 MHz), by normal down-conversion, or by down-conversion of an image (the signal frequency minus the LO approximately equals the IF). Depending on the frequency, amplitude, and timing of the signal source and the tuning mode of the Measuring Receiver, a tuning error may or may not be sensed. If the instrument does not retune, frequency and level measurement results may not be as expected.

When Measuring Frequency Agile Sources or Multiple Signal Sources.

Whenever tuning to signals less than 2.5 MHz, the input signal passes directly into the IF. The LO is used only to turn on the mixer. However, since the Measuring Receiver arbitrarily sets the LO to 101.5 MHz, a passband is created from 99 to 104 MHz. If this frequency band causes a measurement problem, manually tune the LO so the passband for the down converted signal falls in an unoccupied region of the input spectrum. This method is not a preferred way to make measurements, but it might enable you to make some desired measurements. Note that when using this method you should disable Error 01 (by selecting 8.1 SPCL) to prevent the Measuring Receiver from trying to tune to a down-converted signal rather than the signal that is less than 2.5 MHz.

Manual Tuning.

When tuning manually, it is possible to accidentally adjust the LO so that the input signal falls in the image passband; for example, when using the kHz (up arrow) and kHz (down arrow) keys. Frequency measurements are inaccurate when the instrument is tuned to an image. (Refer to *RF Frequency Tuning* on page 3-141 for an illustration of the image passbands.)

Measuring Frequencies below -60 dBm.

The high gain of the IF Amplifier and Limiters makes it possible to measure the frequency of input signals below -60 dBm. In automatic tuning, the instrument tunes to the strongest signal at the input. When manually tuned to the approximate input frequency, the instrument ignores more powerful signals when they or their images fall outside the IF passband.

Extend the range of measurable signal levels for automatic and manual tuning by inserting the RF amplifier (Special Function 1). (Refer to *RF Input Attenuation and Gain* on page 3-265.)

Input/Output Status.

When the **FREQ** key selected, the **MODULATION OUTPUT** signal continues to be the last selected modulation signal, filtered, and/or de-emphasized (except **PRE DISPLAY**) as previously selected (as indicated by the **MODULATION OUTPUT** annunciator). Calibration of this output depends on the IF signal level and should be assumed only when all errors are enabled (Special Function 8.8).

RF Frequency Tuning

FUNCTIONS

TRACK MODE, AUTO TUNING, DISPLAY FREQ INCR, kHz \uparrow and kHz \downarrow keys

DESCRIPTION

The Measuring Receiver is considered tuned to an input signal when the frequency of the Local Oscillator (LO) produces an IF signal centered in the IF passband. Normally the LO frequency is tuned either 1.5 MHz or 455 kHz above the input signal, depending on which IF is selected. When the input signal is less than 2.5 MHz, the LO is tuned to 101.5 MHz and the input passes directly into the IF.

The Measuring Receiver can be automatically or manually tuned to the input signal:

In automatic tuning, the instrument searches for the presence of a signal over the entire input spectrum. Once found, the LO is tuned so that the signal is centered properly in the IF.

In manual tuning, the desired input frequency is entered via the numeric keyboard or kHz \uparrow and kHz \downarrow keys, and the LO is tuned so that a signal of that frequency would be centered properly in the IF.

For both of these tuning modes, the LO can be configured to lock itself to an internal crystal oscillator (for low-noise measurements) or to track the input signal as it drifts (keeping the down-converted signal centered in the IF).

The four tuning modes are listed below:

- Automatic Tuning; Low-noise LO
- Automatic Tuning; Track Mode,
- Manual Tuning; Low-noise LO, and
- Manual Tuning; Track Mode.

Automatic Tuning–Low-Noise LO.

If not already tuned, the Measuring Receiver searches throughout its frequency range for an input signal. If two input signals have similar power levels, the higher frequency signal is usually selected. The RF input signal's second and third harmonic levels must be at least 10 dB below the level of the fundamental, and all other signals at the input must be at least 30 dB below the level of the desired signal. Once tuned, the LO is locked to an internal, voltage-controlled, crystal oscillator for highly-stable, low-noise measurements. Tuning is maintained as long as a detectable signal is present. If the input signal disappears (drops below -20 to -25 dBm), the Measuring Receiver initiates a signal search. This tuning mode is selected whenever Automatic Operation is pressed and when the instrument powers-up.

Automatic Tuning–Track Mode.

The instrument searches for the input signal in the same way as described in the previous paragraph; however, it does not lock to the internal reference oscillator. Instead, the LO is locked to the input signal itself and tracks it as it drifts. This function is useful for checking modulation or level as a function of carrier frequency. If the input signal disappears (for example, when the LO switches bands) the Measuring Receiver searches for, and re-acquires the input signal. Track Mode tuning is not allowed with the 455 kHz IF or with input signals below 10 MHz. Track Mode tuning somewhat attenuates low-rate FM on the input signal; thus, FM measurements should only be made in track

mode when modulation rates exceed 1 kHz. Also, Track Mode tuning is not recommended where optimum noise performance is required.

Manual Tuning—Low-Noise LO.

The instrument tunes to the frequency keyed into it, via the keyboard, regardless of whether a signal is present. Once tuned, the LO is locked to an internal voltage-controlled, crystal oscillator for high stability and low noise. Once locked, tuning does not change unless a new frequency is entered, Track Mode is selected, the tuning is stepped up or down using the kHz \uparrow or kHz \downarrow keys, Automatic Operation or Instrument Preset is selected. The manual tune mode is entered immediately when either MHz, kHz \uparrow , or kHz \downarrow is selected; or if Range Hold is selected. (Note that this tune mode can be used for tuned RF level measurements when used in conjunction with Special Function 32.9.¹ Refer to *Tuned RF Level* comment, “32.9 SPCL: Tuned RF Level Measurements Using Track-Mode Tuning” on page 3-105.)

Manual Tuning—Track Mode.

The Measuring Receiver tunes to the keyed-in frequency in the same way as described in the previous paragraph. However, the LO is not locked to an internal oscillator; instead the LO is locked to the input signal itself and tracks it as it drifts. This function is useful for measuring second or third harmonic signals and for tracking spurious signals.

PROCEDURE

Select **FREQ.**

Tune Mode Selection:

- Select automatic tuning with **AUTOMATIC OPERATION** or **AUTO TUNING** (Blue Key, **TRACK MODE**).
- Select manual tuning with either **MHz** or one of the **kHz** keys (with or without a preceding numeric entry), or with **RANGE HOLD**.
- Select track mode with **TRACK MODE**. (Return from the track mode to the low-noise mode, by selecting **TRACK MODE** again.)

Manual Tuning by Keyboard Entry:

To manually tune to a specific signal frequency, enter the frequency in MHz via the numeric keyboard, then press the **MHz** key.

The **MHz** key can also be used alone to aid in tuning: if the Measuring Receiver is tuned close but not exactly to the input signal, select **MHz** to center the signal in the IF passband. If in automatic tuning mode, and no signal is present, select **MHz** alone to tune the Measuring Receiver to the last frequency at which a signal was successfully tuned. (If no previous successful tuning has been made, the Measuring Receiver tunes to 100 MHz.)

RF Frequency Stepping:

To step the tuning of the Measuring Receiver, enter the desired frequency step size in kHz via the numeric keyboard, then press either kHz \uparrow or kHz \downarrow . Once the step size has been set, either kHz key will change the tuning by that step size each time the key is pressed. (At power-up, the step size is set to 0 kHz.)

¹ This special function is not available with firmware date codes 234.1985 and below. (To display the firmware date code, select 42.0 SPCL.) To order a ROM set that contains this special function, contact the nearest HP sales office.

HP-IB PROGRAM CODES

When operating the Measuring Receiver via HP-IB, the units for the frequency steps can be either Hz or kHz.

AUTO TUNING = AT
 AUTOMATIC OPERATION = AU
 Display Frequency = FR
 Display Increment = FN
 Hz, Input Frequency Entry = HZ
 MHz, Input Frequency Entry = MZ
 Ranging Automatic = G0
 RANGE HOLD = G1
 Step Up (Hz) = HU
 Step Down (Hz) = HD
 Step Up (kHz) = KU
 Step Down (kHz) = KD
 TRACK MODE off = K0
 TRACK MODE on = K1

COMMENTS

RF Frequency Stepping.

Using the kHz \uparrow and kHz \downarrow keys, the tuning of the Measuring Receiver can be changed by a selectable frequency step (in kHz). This feature is most often used in conjunction with the frequency error function. The kHz keys can be used regardless of tune mode, but when pressed, the tuning mode reverts to manual tuning. If these keys are pressed in an automatic tuning mode, the instrument will tune to the last successfully tuned frequency plus or minus the frequency step. Once a frequency step is entered on the keyboard (refer to "PROCEDURE"), pressing either of the kHz keys alone will change tuning by that step size until a new step frequency is defined. At power-up, the step size is zero.

HP-IB

RF frequencies can be changed in fundamental-units (Hz) steps via the HP-IB. These steps are not possible from the front panel:

Hz Step Up = HU
 Hz Step Down = HD

Tuning to Signals with Low-Rate, High-Deviation FM.

The instrument will not automatically tune to a signal that has low-rate, high-deviation FM. Use a manual tune mode to measure such signals.

Tuning to Signals with Narrow-Band FM and Φ M.

The automatic tuning, low-noise LO mode is adequate for most common measurements. It should always be used for measuring narrow-band FM and Φ M.

Measuring Flatness as a Function of Carrier Frequency.

Automatic tuning, track mode is useful for measuring modulation or peak tuned RF level flatness as a function of carrier frequency. (Select Peak Tuned RF Level with Special Function 36.)

Tuning to Low-Level Signals.

Manual tuning, low-noise mode should be used with signals that may drop below the minimum threshold for automatic tuning. Manual tuning makes it possible to make tuned modulation and frequency measurements on very low-level signals.

Measuring Drift.

Manual tuning, track mode is useful for measuring drift on low-level signals in the presence of higher-level signals.

Determine Tuning Accuracy.

When manually tuning or frequency stepping, use the frequency error measurement to determine tuning accuracy.

Image Frequencies.

When the Measuring Receiver tunes to an input signal greater than 2.5 MHz, the IF frequency positions the internal LO above the nominal tuning. The Measuring Receiver, however, will respond equally well to a signal at the image frequency, that is, when the signal frequency minus the LO is within the IF passband. (For example, if the LO is at 101.5 MHz, signals at either 100 MHz or 103 MHz (the image) generate a 1.5 MHz IF.) When the instrument is tuned to an image, measurement errors may result with no Error Message displayed. (The input frequency measurement will always be in error. For FM and Φ M measurements, the Peak+ and Peak- functions are reversed. One way to solve this problem is to step the tuning down by twice the IF frequency, or let the instrument automatically tune. The following IF response plot illustrates the image passbands for each IF frequency. (Tuned RF Level does not apply.)

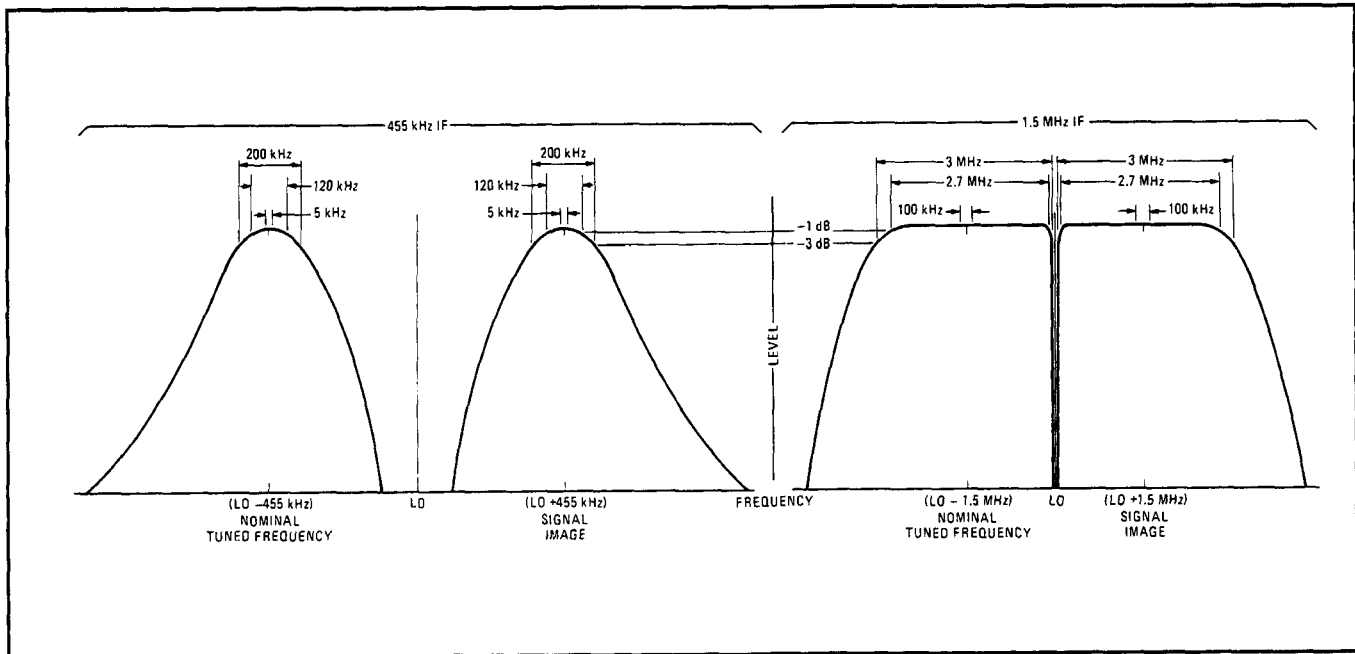

455 kHz and 1.5 MHz IF Passband Responses

When Measuring Frequency Agile Sources or Multiple Signal Sources.

Whenever tuning to signals less than 2.5 MHz, the input signal passes directly into the IF. The LO is used only to turn on the mixer. However, since the Measuring Receiver arbitrarily sets the LO to 101.5 MHz, a passband is created from 99 to 104 MHz. If this frequency band causes a measurement problem, manually tune the LO so the passband for the down converted signal falls in an unoccupied region of the input spectrum. This method is not a preferred way to make measurements, but it might enable you to make some desired measurements. Note that when using this method you should disable Error 01 (by selecting 8.1 SPCL) to prevent the Measuring Receiver from trying to tune to a down-converted signal rather than the signal that is less than 2.5 MHz.

Frequencies Greater Than 10 MHz.

When making measurements on inputs with frequencies greater than 10 MHz, signals present at the input that are less than 2.5 MHz pass directly into the IF. These low-frequency signals can be removed by inserting the RF input high-pass filter. (Refer to *Filters, RF and IF* on page 3-259).

Searching for a Signal.

When manually tuning, often the exact input frequency is unknown. If during tuning, Error 01 (signal out of IF range) is displayed, select the MHz key alone to center the signal in the IF. Also, if searching for a signal using the kHz keys, it is best to search down from above the signal frequency while monitoring IF LEVEL. (Refer to *IF Level* on page 3-109.) When the IF level rises significantly, switch to **FREQ ERROR** and enter the displayed value as a frequency step and complete tuning using the kHz keys.

Default Conditions.

When the Instrument Preset key is pressed, or on power-up, the Measuring Receiver selects the automatic tuning, low-noise LO mode.

Responding to Frequency Changes.

Using the automatic tune mode, the Measuring Receiver might not retune when the frequency changes, but its spectrum still has sufficient power within the tuned passband of the Measuring Receiver's RF INPUT. It will appear that the carrier simply changed its level. If the instrument does not retune, frequency and level measurement results might not be as expected. Use a manual tune mode, if possible, in the following situations:

- When working with frequency agile sources (such as frequency synthesizers) that have a frequency hopping function.
- When changing frequency in harmonic steps.

Extending Tuned Measurements Below 2.5 MHz.

Use the following procedure to extend the range of tuned measurements below 2.5 MHz.

NOTE

Only the 455 kHz IF can be selected. The minimum input frequency is 795 kHz. Measurement accuracy may be degraded. IF signal may appear at the modulation monitoring connectors.

1. Select INSTR PRESET (Blue Key, AUTOMATIC OPERATION).
2. Set the signal source to a carrier frequency between 3 and 9 MHz and to the level of the intended measurement.
3. Connect the signal source to the Measuring Receiver's INPUT (or to a properly connected sensor module). Allow the Measuring Receiver to tune to the input signal.
4. Select RANGE HOLD. Select DISABLE ERROR (Blue Key, RANGE HOLD).
5. Enter the frequency value of the input signal and retune the signal source to that frequency.
6. Select the desired measurement mode. (RANGE HOLD and DISABLE ERROR can be released at this time. RANGE HOLD must be released for Tuned RF Level.)

RF Frequency Error

FUNCTIONS

FREQ ERROR

DESCRIPTION

The Frequency Error function enables the Measuring Receiver to measure the difference (in kHz) between the RF input signal frequency and the frequency to which the instrument is tuned. This function can be used to observe frequency drift of input signals, or to compare input frequencies against a keyboard-entered reference.

Display resolution is controlled by Special Function 7. (Refer to *RF Frequency Resolution* on page 3-157.)

PROCEDURE

To make the RF frequency error measurement, connect the RF signal to the Measuring Receiver's RF INPUT.

If a frequency drift measurement is to be made, first allow the Measuring Receiver to automatically tune to the signal, then select the MHz key to prevent retuning. Select FREQ ERROR (Shift, FREQ) to display the frequency error. As the signal drifts the display indicates the magnitude and direction of the drift.

To make a frequency comparison, enter the reference frequency (in MHz) on the keyboard, then select MHz. Select FREQ ERROR to display the difference frequency. The number is negative if the signal frequency is lower than the reference, and positive if the signal frequency is higher than the reference. Valid frequency error measurements are made as long as the down-converted signal remains in the IF passband. (Refer to *RF Frequency Tuning* on page 3-141.)

EXAMPLE

To measure the error of an oscillator designed to operate at 30 MHz, connect the oscillator's output to the Measuring Receiver's RF INPUT connector and select the following keystrokes:

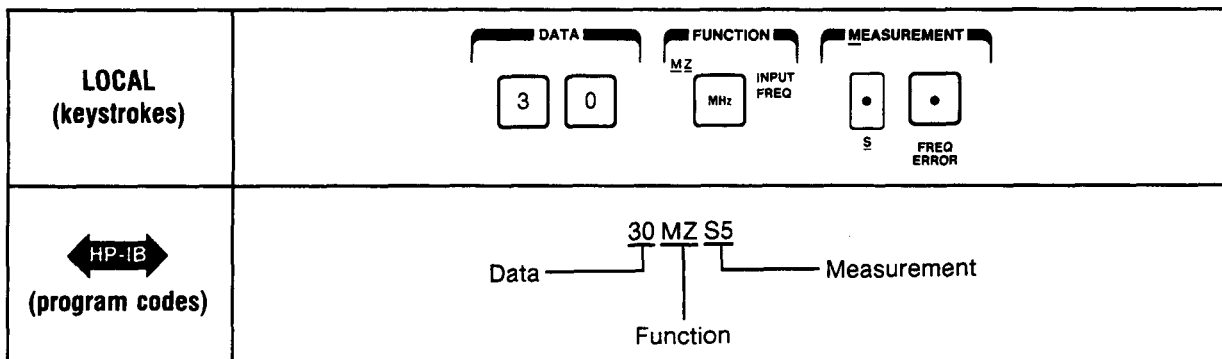

HP-IB PROGRAM CODES

FREQ ERROR = S5
MHz = MZ

MEASUREMENT TECHNIQUE

When the Measuring Receiver is tuned, the IF signal is amplified and limited. If manually tuned, the RF input frequency is measured and compared to either the keyboard-entered frequency or to the frequency measured after the MHz key is pressed. The frequency difference is displayed as frequency error.

If the Measuring Receiver is automatically tuned, two methods of determining frequency error are used:

- When the input signal is greater than 2.5 MHz, the frequency of the actual IF signal is subtracted from the selected IF frequency (455 kHz or 1.5 MHz) to determine the frequency error.
- When the input signal is less than 2.5 MHz, the input signal is passed directly into the IF without down-conversion. When the signal is first located, the frequency is counted. When the FREQ ERROR key is selected, this first-counted frequency becomes the reference. Subsequent frequency counts are subtracted from this reference, and the results are displayed as frequency error.

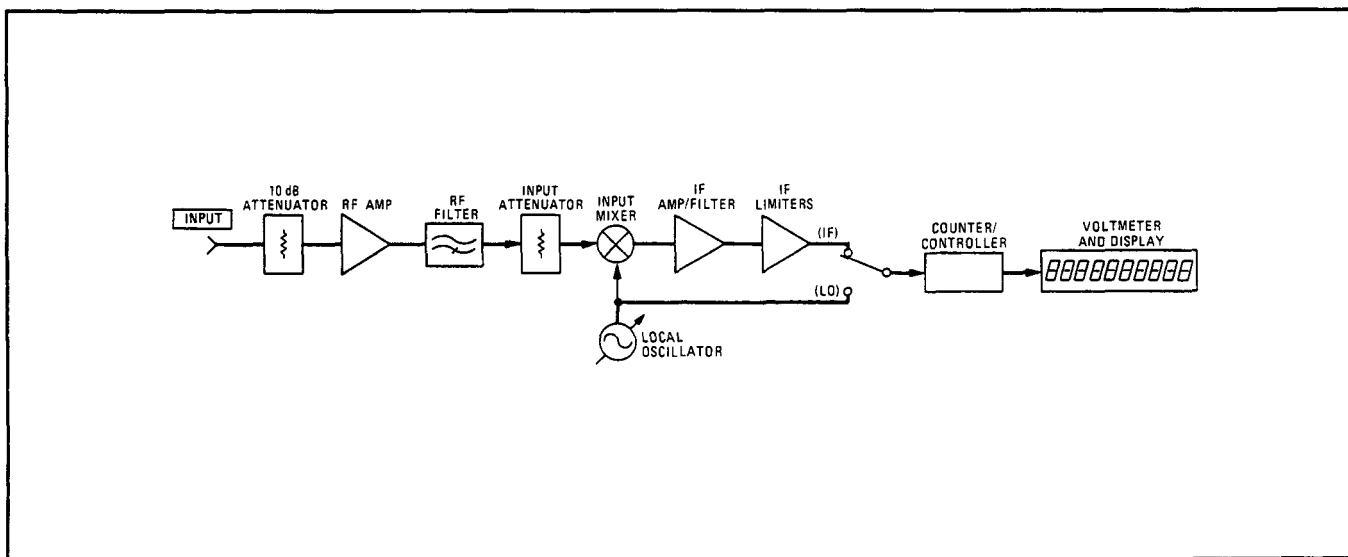

RF Frequency Error Measurement Block Diagram

COMMENTS

Down-Converted Signals.

The down-converted RF input frequency must fall within the passband of the IF being used. For the 1.5 MHz IF, the passband is approximately 3 MHz wide. For the 455 kHz IF, the passband is approximately 200 kHz wide.

Input/Output Status.

When the instrument is measuring frequency error, the output signal available at MODULATION OUTPUT/AUDIO INPUT is the same as for the last modulation measurement (as indicated by the MODULATION OUTPUT annunciator).

Relative Measurements.

If frequency error is to be displayed relative to a reference, enter the value as a ratio reference using the RATIO key. (Refer to *Ratio* on page 3-245.)

Use Manual Tuning for Best Measurements.

The frequency error function can be used with the automatic tuning low-noise LO tune mode, but it is most valuable when used with manual tuning (normal or Track Mode). It is not recommended that frequency error be used when in automatic tuning track mode, since an inherent tuning offset exists in this mode.

Step Frequency Aids Multi-Channel Measurements.

Check channel accuracy on multi-channel transmitters using the frequency error function in conjunction with the kHz \uparrow and kHz \downarrow keys. Set the step frequency to the channel spacing to quickly determine the accuracy of evenly-spaced channels.

LO in Image Passband Distorts Measurements.

When tuning manually, it is possible to accidentally adjust the LO so that the input falls in the image passband; for example, when using the kHz \uparrow and kHz \downarrow keys. Frequency error measurements are inaccurate when the input image enters the IF passband. Refer to *RF Frequency Tuning* on page 3-141 for an illustration of the image passbands.

Changing Resolution.

Normally, the counter updates the display five times each second. For selection of other resolutions, use Special Function 7. (Refer to *RF Frequency Resolution* on page 3-157.) Counter accuracy is the reference accuracy ± 3 counts.

Input/Output Status.

When the Frequency Error function is selected, MODULATION OUTPUT/AUDIO INPUT continues to output the last-selected modulation signal, filtered and/or de-emphasized (except PRE DISPLAY) as previously selected. The calibration of this output depends on the input signal level and should be assumed only when all errors are enabled (Special Function 8.8).

Parts Per Million Display.

To display frequency error in parts per million (ppm), first display the frequency error, then enter 1/10 the reference frequency (in MHz) as a ratio reference, and select RATIO. The display shows the frequency error in parts per million.

IF Frequency

FUNCTIONS

Special Function 34 (IF Frequency)

DESCRIPTION

The Measuring Receiver makes tuned (down-converted, heterodyned) measurements on its RF input signal using one of two IF frequencies. Three combinations of tuning and IF selection are used:

1. When RF input signals less than 2.5 MHz are measured, the RF input signal passes directly into the IF without down-conversion; that is, the RF input frequency and the IF frequency are the same. (Tuned measurements can be manually extended below 2.5 MHz. Refer to *RF Frequency Tuning* on page 3-141.)
2. When RF input signals greater than 2.5 MHz, but less than 10 MHz are measured, the signal is down-converted to a 455 kHz IF. (The 455 kHz IF is also selected when making the Tuned RF Level measurements; irrespective of RF frequency.)
3. When RF input signals greater than 10 MHz are measured, the signal is down-converted to a 1.5 MHz IF. (Note that special Function 3 can be used to select the 455 kHz IF. Refer to *Filters, RF and IF* on page 3-259.)

Special Function 34.0 enables the Measuring Receiver to measure and display the IF frequency for the signal being measured.

PROCEDURE

To measure the IF frequency, key in 34.0 SPCL.

MEASUREMENT TECHNIQUE

The IF signal, generated when the Local Oscillator and the RF input signal mix, is amplified by the IF Amplifier and FM Limiters and then counted. The IF frequency is displayed when Special Function 34 is used. When measuring RF input frequencies greater than 2.5 MHz, the Measuring Receiver uses either the 455 kHz or 1.5 MHz IF. For RF input frequencies less than 2.5 MHz, down-conversion is not normally used and the RF input signal passes directly into the IF.

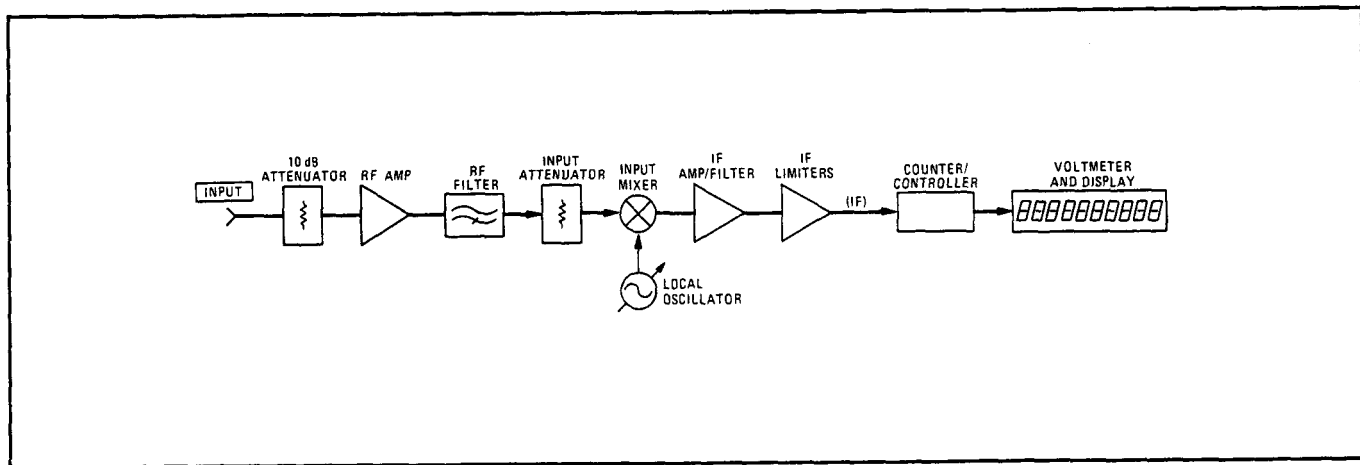
BLOCK DIAGRAM*IF Frequency Measurement Block Diagram***COMMENTS****Input/Output Status.**

When the instrument is measuring IF frequency, the signal at MODULATION OUTPUT/AUDIO INPUT remains unchanged.

Relative Measurements.

If IF frequency is to be displayed relative to a reference, enter the ratio reference using the RATIO key. (Refer to *Ratio* on page 3-245.)

Frequency Resolution.

Normally, the counter updates the display five times each second. For selection of other resolutions, use Special Function 7. (Refer to *RF Frequency Resolution* on page 3-157.) Counter accuracy is the reference accuracy ± 3 counts.

IF Filter Selection.

IF filter selection is dependent on the selected IF Frequency. (Refer to *Filters, RF and IF* on page 3-259.)

When using the 455 kHz IF on input signals with frequencies greater than 300 MHz, incidental AM (that is, AM due to FM) increases substantially.

RF Input Frequency Calculation.

The Measuring Receiver determines the frequency of the RF input signal by counting the frequencies of both the IF and LO and calculating their difference.

IF Frequency Accuracy.

The IF frequency need not be exactly its nominal value in order to guarantee accurate modulation measurements. Unless specifically overridden by Special Function 8 or DISABLE ERROR (Blue Key, RANGE HOLD), Error Messages safeguard the measurements. (Refer to *Error Message Disable Control* on page 3-267 and *RF Frequency Tuning* on page 3-141.)

LO Frequency

FUNCTIONS

Special Function 33 (LO Frequency)

DESCRIPTION

Special Function 33.0 enables the Measuring Receiver to display the local oscillator (LO) frequency.

PROCEDURE

To measure the LO frequency, key in 33.0 SPCL.

MEASUREMENT TECHNIQUE

The LO frequency is essentially measured directly by the counter. The frequency that the LO is tuned to depends on (1) whether automatic tuning or manual tuning is being used, (2) whether the RF input signal is being down-converted, and (3) which IF is being used. The following table summarizes LO tuning. (Refer to *RF Frequency Tuning* on page 3-141 for more information.)

Tuning Mode	Down Conversion	Selected IF	Approximate LO Frequency
Automatic	Yes	1.5 MHz	Input + IF
	Yes	455 kHz	Input + IF
	No	1.5 MHz	101.5 MHz
Manual	Yes	1.5 MHz	Keyed In + IF
	Yes	455 kHz	Keyed In + IF
	No	1.5 MHz	101.5 MHz

BLOCK DIAGRAM

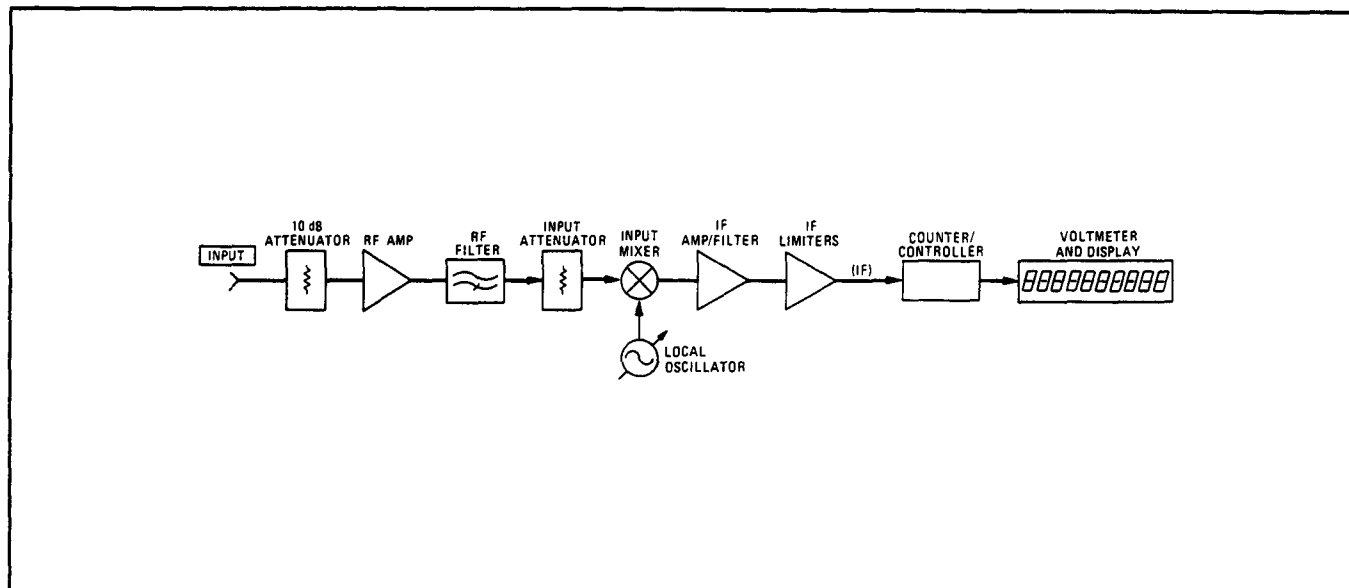

LO Frequency Measurement BLOCK DIAGRAM

COMMENTS

Input/Output Status.

When the instrument is measuring the LO frequency, the signal at MODULATION OUTPUT/AUDIO INPUT remains unchanged.

Relative Measurements.

If the LO frequency is to be displayed relative to a reference, enter the value as a ratio reference using the RATIO key. (Refer to *Ratio* on page 3-245.)

Display Resolution.

Normally, the counter updates the display five times each second. For selection of other resolutions, use Special Function 7. (Refer to *RF Frequency Resolution* on page 3-157.) Counter accuracy is the reference accuracy ± 3 counts.

LO Does Not Phase Lock to INPUT.

In general, LO tuning is never exact but is close enough to give calibrated measurements. The LO does not phase lock to the RF input signal.

LO Frequency for INPUT Less Than 2.5 MHz.

When the RF input signal is less than 2.5 MHz, the LO frequency is set to 101.5 MHz. This frequency is arbitrary. The LO must remain on to allow the RF input signal to pass through the input mixer. Note that 101.5 MHz is the frequency the LO is set to for a 100 MHz RF input signal with an IF of 1.5 MHz.

LO Input and LO Output (Option 003)

CAUTION

Do not apply greater than 40 Vdc or +5 dBm of RF power into the LO INPUT or damage to the instrument may result. Do not apply dc voltage or RF power into the LO OUTPUT or damage to the instrument may result.

DESCRIPTION

In Measuring Receivers with Option 003, the internal local oscillator (LO) signal is routed through the rear-panel LO OUTPUT and LO INPUT connectors. The range of the LO signal is 1.27 MHz to 1301.5 MHz, at approximately 0 dBm. Both connectors are 50Ω, ac-coupled, Type-N connectors.

NOTE

The rear-panel LO OUTPUT must be connected to the rear-panel LO INPUT for normal Measuring Receiver operation that uses the internal local oscillator.

BLOCK DIAGRAM

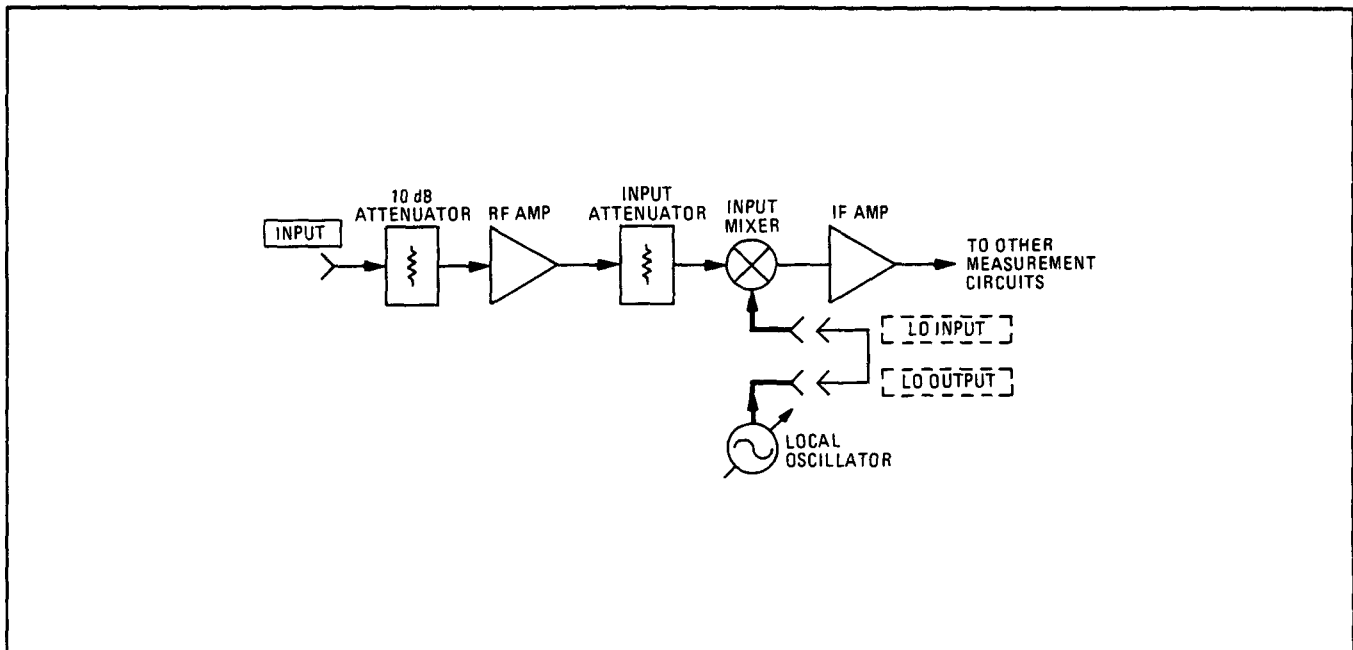

LO Input and LO Output Block Diagram

PROCEDURE

To use LO OUTPUT as a signal source:

1. Select an IF frequency of either 1.5 MHz or 455 kHz using Special Function 3. (If the IF frequency is not specified, the Measuring Receiver will assume the 1.5 MHz IF for keyboard-entered frequencies greater than 10 MHz and the 455 kHz IF for frequencies less than 10 MHz but greater than 2.5 MHz.)
2. Subtract the IF frequency from the frequency desired at LO OUTPUT, and enter the result, in MHz, via the numeric keys; then press the MHz key. (To tune the LO below 2.96 MHz, use the procedure as described, but select the 455 kHz IF using Special Function code 3.1, and disable Error 01 using Special Function code 8.1.)
3. Connect the LO OUTPUT to the desired input.

The LO frequency can be monitored using Special Function 33. (Refer to *LO Frequency* on page 3-153.)

To use an external source as the LO INPUT:

1. Select an IF frequency (1.5 MHz or 455 kHz) using Special Function 3.
2. Press the MHz key to enter manual tune mode (to prevent the internal LO from continuously tuning).
3. Add the IF frequency to the frequency to which the Measuring Receiver is to be tuned, and set the external LO to that frequency.
4. Adjust the external LO to 0 dBm and connect it to the LO INPUT.

COMMENTS

Using the LO OUTPUT.

LO tuning is not exact. The instrument tunes the LO only close enough to make calibrated measurements.

Using the LO INPUT.

To tune to inputs below 2.5 MHz with an external LO, select the 1.5 MHz IF, but set the LO to approximately 100 MHz. LO signal is required for the Input Mixer to function even when down-conversion is not desired.

Invalid Frequency Measurements (RF and LO).

When an external LO is used, measurements made using the **FREQ** or **FREQ ERROR** keys are invalid. To determine input frequency, subtract the IF frequency (34.0 SPCL) from the LO frequency used.

The LO frequency function (33.0 SPCL) continues to measure the internal LO.

FM Transients Using an External LO.

When using an external LO, rapid changes in LO frequency within the IF passband cause FM transients. Several seconds are then required before accurate measurements are possible. To avoid the problem, turn off the external LO when switching its frequency.

RF Frequency Resolution

FUNCTIONS

Special Function 7 (RF Frequency Resolution)

DESCRIPTION

When making RF measurements, the frequency resolution can be manually set using Special Function 7.

When RF frequency measurements are made, the Measuring Receiver normally updates the display five times each second. The instrument automatically selects 10 Hz resolution for frequencies below approximately 2.5 MHz; 100 Hz resolution for frequencies from approximately 2.5 to approximately 320 MHz; and 1000 Hz resolution for frequencies greater than approximately 320 MHz. Use the numeric keyboard and the SPCL key to set the frequency resolution to either 1000, 100, or 10 Hz. (A resolution of 0.1 Hz or 1 Hz can be selected for RF frequency measurements.)

Special Function 7 sets the measurement resolution for RF Input Frequency, RF Frequency Error, IF Frequency, and LO Frequency Measurements.

PROCEDURE

To set the frequency resolution to a selected range or to re-enter the automatic selection mode, key in the corresponding Special Function code, then SPCL: (Note that with finer resolution, measurement time increases.)

7.0 Automatic selection.

7.1 Resolution of 10 Hz.

7.2 Resolution of 100 Hz.

7.3 Resolution of 1 kHz.

7.4 ¹ (Applies to RF Frequency measurements only; other measurements treat 7.4 as 7.1.) Resolution of 0.1 Hz for input signals less than 10.1 MHz; resolution of 1 Hz for signals from 10.1 MHz through 1300 MHz. (When measuring frequencies as high as 1300 MHz, measurement time with this resolution is approximately 20 seconds.)

COMMENTS

Change Resolution Any Time.

The Measuring Receiver need not be making RF frequency measurements in order to change resolution modes; however, the resolution mode only affects RF frequency-related measurements. Counter accuracy is the reference accuracy +3 counts.

RF Frequency Measurements Greater Than 20 GHz

When making RF frequency measurements greater than 20 GHz, 7.1 SPCL selects 100 Hz resolution.

¹ This special function is not available with firmware date codes 234.1985 and below. (To display the firmware date code, select 42.0 SPCL.) To order a ROM set that contains this special function, contact the nearest HP sales office.

Modulation Measurements Contents

AM

AM	3-161
• How to measure AM depth.	
AM ALC Response Time	3-165
• How to optimize AM ALC response time vs. modulation rate.	
• How to turn ALC off.	
AM Calibration	3-167
• How to verify AM calibration.	
AM Output	3-173
• How to use the rear-panel AM OUTPUT to obtain demodulated AM.	

FM

FM	3-177
• How to measure FM deviation.	
FM Calibration	3-181
• How to verify FM calibration.	
FM De-Emphasis	3-187
• How to equalize pre-emphasized FM signals.	
FM Output	3-191
• How to use the rear-panel FM OUTPUT to obtain demodulated FM.	
Tone-Burst Receiver	3-193
• How to set up the instrument to output demodulated squelch-tone bursts.	

Φ M

Φ M	3-197
• How to measure Φ M deviation.	

AUDIO DETECTORS

Audio Detectors	3-201
• How to select the peak, average, and rms audio detectors.	
Audio Detector Response	3-205
• How to trade off readability of noisy signals for measurement time.	

GENERAL MODULATION MEASUREMENT FUNCTIONS

Audio Filters	3-207
• How to select the high-pass and low-pass noise filters which filter the demodulated signal.	
Audio Range	3-211
• How to vary the display resolution and MODULATION OUTPUT sensitivity.	
Modulation Output/Audio Input	3-215
• How to use the MODULATION OUTPUT/AUDIO INPUT to obtain the demodulated, audio signal.	
• How to use the MODULATION OUTPUT/AUDIO INPUT to input an external audio signal for audio analysis.	
Residual Noise Effects	3-219
• How to account for noise to make the most accurate peak-modulation measurements.	

AM

FUNCTIONS

AM, Special Function 2 (Audio Range)

DESCRIPTION

Selecting AM enables the Measuring Receiver to measure the AM depth of the tuned RF input signal. (Selecting Special Function 2 sets measurement limits on the range of AM depth at the same time a specific display resolution is set.)

AM measurements are specified for rates from 20 Hz to 10 kHz for carrier frequencies 10 MHz and below (or whenever the 455 kHz IF is used) and from 20 Hz to 100 kHz for carrier frequencies from 10 to 1300 MHz (1.5 MHz IF only). The corresponding 3 dB audio bandwidths are approximately 0.5 Hz to 15 kHz for carriers 10 MHz and below (or with the 455 kHz IF) and approximately 0.5 Hz to 260 kHz for carriers from 10 to 1300 MHz (1.5 MHz IF only). (Special Function 6.1 will modify the lower frequency.) Modulation depths to 99% can be measured.

The demodulated signal's frequency and distortion can also be measured. (Refer to *Audio Measurements* section which starts on page 3-225.)

PROCEDURE

To make an AM measurement, first tune the instrument to the input signal by selecting AUTOMATIC OPERATION. Select AM.

Select an audio detector: PEAK+, PEAK-, PEAK±/2, AVG, or RMS. The RMS detector (Blue Key, AVG) is less accurate than the other detectors in measuring AM, has a reduced bandwidth, and is typically only used for audio distortion measurements.

The following table lists the different measurement range limits that can be selected with Special Function 2:

Modulation Range Peak± (%)	Detector Selected	Special Function Code	Program Code ↔ HP-IB ↔	Display Resolution (%)	MODULATION OUTPUT Sensitivity (Vac/% AM)
Automatic Selection		2.0 SPCL	2.0SP	Automatic Selection	
≤4	RMS	2.4 SPCL	2.4SP	0.001	0.1
≤40	Pk, Avg	2.4 SPCL	2.4SP	0.01	0.1
≤40	Pk, Avg, RMS	2.1 SPCL	2.1SP	0.01	0.1
≤100	Pk, Avg, RMS	2.2 SPCL or 2.3 SPCL	2.2SP or 2.3SP	0.1	0.01

To filter the demodulated signal, select the desired filter. (Refer to *Filters, Audio* for more information about filters.)

EXAMPLE

To measure the positive peak AM depth of a signal in a 50 Hz to 15 kHz demodulated signal bandwidth:

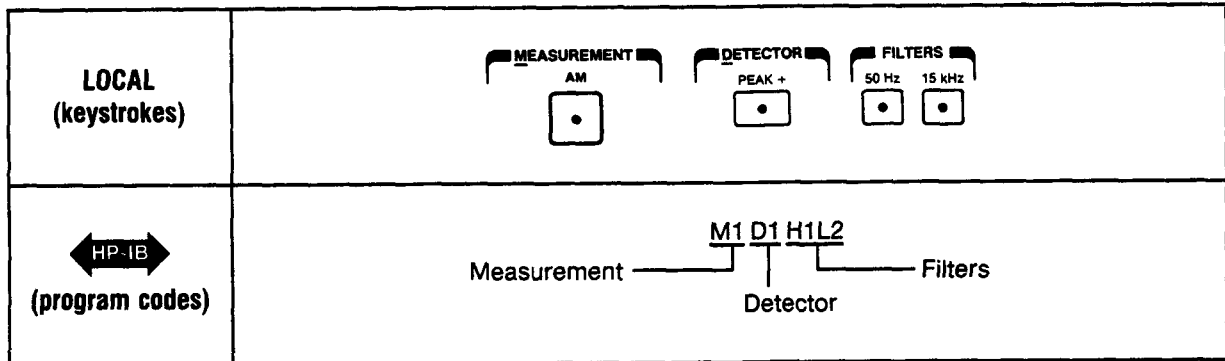

HP-IB PROGRAM CODES

All HP-IB codes for setting a limit or a specific display resolution for modulation-depth measurements are provided in "Procedures".

AM = M1
SPCL = SP

MEASUREMENT TECHNIQUE

The AM Demodulator measures AM as a ratio of the demodulated audio signal level to the average tuned carrier level. An automatic level control (ALC) loop within the AM Demodulator holds the carrier level constant so that the percent AM is proportional to the peak amplitude of the demodulated audio output. This audio output is then filtered, audio detected, and displayed as % AM. The demodulated AM is available at MODULATION OUTPUT/AUDIO INPUT (unless AUDIO INPUT is selected).

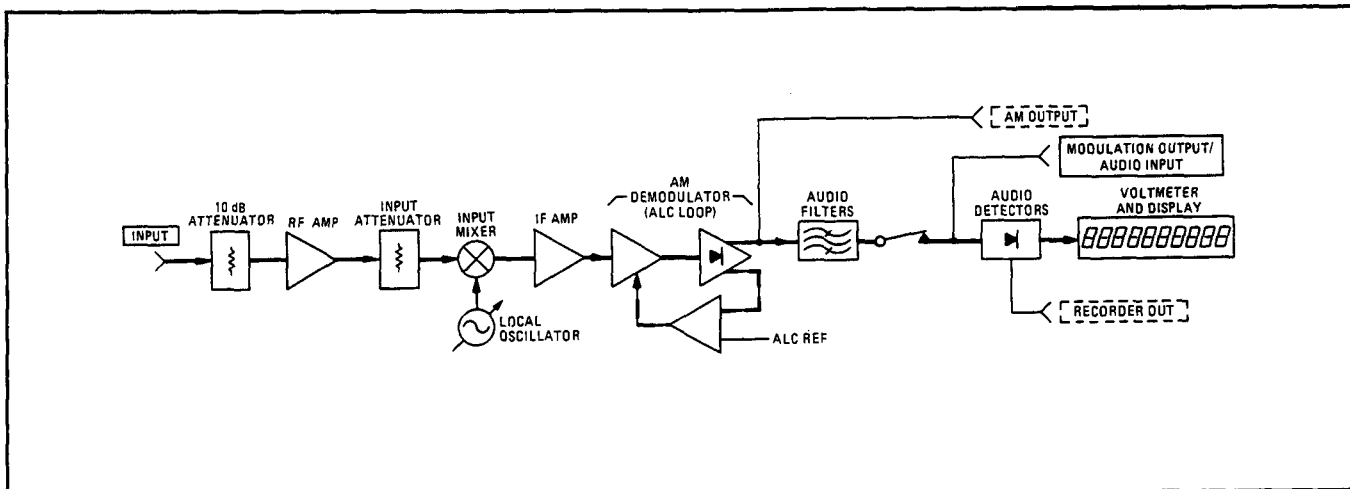

AM Measurement Block Diagram

COMMENTS

Input/Output Status.

The demodulated AM is present at MODULATION OUTPUT/AUDIO INPUT (unless AUDIO INPUT has been selected). The demodulated AM is usually present at the rear-panel AM OUTPUT connector. (Refer to *AM Output* on page 3-173.)

Peak \pm /2 Detector.

The PEAK+ detector always detects the peak of the carrier envelope while the PEAK- detector always detects the trough. The PEAK \pm /2 detector sums the peak and the trough readings and divides the total by two to provide an average of the two peak values. (Do not confuse this "average" value with the detected average value.)

Automatic Range Selection.

The routine which automatically selects the modulation range contains a region of overlap between 35 and 40% AM (peak detected). When using the average or RMS detectors, ranging occurs at readings lower than these. In general, if the modulation is reduced from above 40% into the overlap region, only 0.1% resolution is ordinarily displayed although 0.01% resolution is available. To display the increased resolution, press the AM key a second time. Audio Range has more detailed information on the modulation ranges that can be set.

Automatic Filter Selection.

When operating above 2.5 MHz, while using the 455 kHz IF, the upper limit of the demodulated signals modulation rate is that of the >20 kHz LP Filter. The 15 kHz LP Filter is automatically selected when operating below 10 MHz or whenever the 455 kHz IF is selected. However, this filter may be overridden by selecting another LP Filter. The lower limit of the modulation rate is determined by the ALC response time selected. (Refer to *AM ALC Response Time* on page 3-165.)

Inverted Output Signal.

The signal at the rear-panel AM Output is inverted relative to the Modulation Output signal.

Potential Inaccuracies.

AM conditions that cause the carrier signal to disappear (such as 100% AM or pulse modulation) will cause inaccuracies in measurement of FM, RM, or input frequency, or they could cause Error 05 (FM squelched) to be displayed when these measurements are selected.

Increased Accuracy.

Accuracy of AM readings may be improved by calibrating the AM measurement (refer to *AM Calibration* on page 3-167) and by taking into account the effects of residual noise (refer to *Residual Noise Effects* on page 3-219).

Relative AM Depth Measurements.

If AM depth is to be displayed relative to a reference, enter the value as a ratio reference using the RATIO key. (Refer to *Ratio* on page 3-245.)

AM ALC Response Time

FUNCTIONS

Special Function 6 (Automatic Level Control)

DESCRIPTION

The Measuring Receiver normally uses a slow-responding AM automatic level control (ALC) circuit, allowing AM rates as low as 20 Hz to pass unaffected by the leveling loop. (Refer to the figure in *AM*, "Measurement Technique.")

Select a fast ALC response time to speed up the measurement settling time required for varying carrier levels. The faster ALC response time degrades AM accuracy at rates less than 1 kHz.

The ALC can be disabled. This feature, used in conjunction with the rear-panel AM Output connector, is useful for measuring AM at very low modulation rates. Disabling the ALC also permits measuring absolute changes in depth without regard to changes in carrier level (a feature that is useful in characterizing amplitude modulators).

PROCEDURE

The instrument normally operates with a slow AM ALC response time. To change the response time, or to disable the ALC, enter the corresponding Special Function code, then select SPCL.

AM ALC Response	Special Function Code	Program Code ↔ HP-IB ↔
Slow ALC (AM rates >20 Hz)	6.0 SPCL	6.0SP
Fast ALC (AM rates >1 kHz)	6.1 SPCL	6.1SP
ALC off	6.2 SPCL	6.2SP

HP-IB PROGRAM CODES

For HP-IB codes, refer to "PROCEDURE".

COMMENTS

Default Condition.

When the instrument is first turned on, or when Automatic Operation or Instrument Preset is selected, the slow ALC response is selected.

IF Level Dependency.

The displayed modulation depth and the sensitivity of the Modulation Output connector for AM demodulation are incorrect when the ALC is disabled unless the IF level is 100%. (Refer to *IF Level* on page 3-109.)

AM Calibration

FUNCTIONS

CALIBRATE, SAVE CAL, % CAL FACTOR, Special Functions 13 (AM Calibration) and 16 (AM Calibration Factors).

DESCRIPTION

The accuracy of the Measuring Receiver's AM demodulator can be checked with the internal AM calibrator. The calibration process generates a calibration factor to compensate for the AM measurement error (within the accuracy limits of the AM Calibrator). Using the SAVE CAL key or Special Function 16, the calibration factor can then be enabled to automatically correct the measured AM error in subsequent measurements. With the calibration factor enabled, AM measurements can be made with an accuracy typically better than 0.5%. The calibration factor can be enabled, disabled, or displayed at any time.

Other instruments in the HP 8901 and 8902 RF signal analyzer family can be calibrated or cross checked using Special Function 13.

PROCEDURE

Self-calibration

To determine the measurement error of the Measuring Receiver's AM demodulation circuits, first allow at least a half-hour continuous operation before calibration, then perform the following steps:

1. Connect the CALIBRATION AM/FM OUTPUT to the RF INPUT with a 50 Ω cable (or a sensor module with an internal switch such as the HP 11722A) and select AM.
2. Select CALIBRATE. After several seconds, the AM calibration factor is displayed in % and stored (but not enabled unless already enabled).

The instrument displays 100.00% if no error is measured. A display of 100.17% means the AM demodulator in the Measuring Receiver is reading 0.17% high. As long as the CALIBRATE key light is on and the cable is connected, calibration repeats and the AM calibration factor is updated approximately every 17 seconds. To turn off the calibrator, select CALIBRATE or any Measurement key.

NOTE

For optimum accuracy, the instrument should be continuously operating for at least one half hour before calibration is performed. In addition, the first two AM Calibration Factors received after instrument power-up should not be used even if the instrument is already warm, since the circuits in the audio chain may not be fully settled.

Correcting Measurements with the AM Calibration Factor. Once a calibration factor has been determined, the instrument retains that value in its non-volatile memory. This factor may be enabled to automatically correct AM measurements. The calibration factor can also be disabled or displayed.

Selecting % CAL FACTOR or 16.2 SPCL displays the calibration factor being used.

Enter the appropriate front-panel key or Special Function code to manipulate the AM Calibration Factor as described in the following table:

Action: AM Calibration Factor	Measurement Mode	Front-Panel Key or Special Function Code	Program Code 
Disable	Any	16.0 SPCL	16.0SP
Enable	AM (From CALIBRATE mode)	(Blue Key) SAVE CAL	SC
	Any	16.1 SPCL	16.1SP
Display	AM	(Blue Key) % CAL FACTOR*	CF
	Any	16.2 SPCL	16.2SP

* The % CAL FACTOR key displays the status of the calibration factor: The factor is enabled if the value of the calibration factor is displayed, with 0.01% resolution. The factor is disabled if 100% is displayed. (Note the resolution of 1%. A display of 100.00% would be a true, calibration factor reading.)

Calibrating or Cross Checking Another HP 8901 or 8902 RF Signal Analyzer

To compute an AM calibration factor for another RF signal analyzer that has no internal calibrator, or that has an internal calibrator that is to be cross checked, use the Measuring Receiver and its calibrator as follows:

1. Connect the Measuring Receiver's CALIBRATION AM/FM OUTPUT to the RF input of the other RF signal analyzer.
2. Select 13.0 SPCL for the Measuring Receiver. Record the value that appears on the display. This is the computed, calibrated, peak AM depth (excluding noise).
3. Select 13.1 SPCL for both instruments. Record the value that appears on the display of the RF signal analyzer. (If display jitter makes readings difficult, select 5.1 SPCL.) The displayed value is the weighted, peak, residual AM depth of the calibrator's unmodulated output as demodulated by the RF signal analyzer.
4. Select 13.2 SPCL for both instruments. Record the value that appears on the display of the RF signal analyzer. This value is the demodulated, positive, peak AM depth of the calibrator's modulated output. (If display jitter makes readings difficult, select 5.1 SPCL.)
5. On the RF signal analyzer, select PEAK-. Note the value displayed on the RF signal analyzer. If the difference between the results of steps 4 and 5 is three counts or less in the least significant digit, an average between the two need not be computed; use the result from step 4. If the difference between the two results is greater than three counts in the least significant digit, compute the average as follows:

$$(13.2 \text{ result}) = \frac{(\text{result of step 4}) + 2(\text{result of step 5})}{3}$$

6. Compute the AM calibration factor of the RF signal analyzer as follows:

$$AM \text{ Calibration Factor } (\%) = 100 \times \frac{(13.2 \text{ result}) - (13.1 \text{ result})}{(13.0 \text{ result})}$$

7. To use this AM calibration factor to correct AM measurements made with the RF signal analyzer, enter the value as a ratio reference and use the Ratio function in the RF signal analyzer.

The Special Function codes are summarized in the table below:

Function	Special Function Code	Program Code ↔ HP-IB ↔
Display computed peak AM	13.0 SPCL	13.0SP
Display demodulated peak residual AM	13.1 SPCL	13.1SP
Display demodulated peak AM	13.2 SPCL	13.2 SP

HP-IB PROGRAM CODES

HP-IB codes for enabling, disabling, or displaying the internal AM calibration factor are provided in "Procedures". The HP-IB codes for the AM Calibrator Special Function used to calibrate another RF signal analyzer are also provided as part of "Procedures".

AM = M1
 CALIBRATE off = C0
 CALIBRATE on = C1
 SPCL = SP

INDICATIONS

Self-Calibration

When the CALIBRATE key is pressed, approximately 17 seconds pass during which the instrument configures itself and tunes to the calibrator's signal. The display indicates four dashes (----) and lights the % annunciator. Once the AM Calibration Factor has been computed, it is displayed. Subsequent updates occur approximately every 17 seconds.

Correcting Measurements with the AM Calibration Factor (Self-Calibrated).

When the calibration factor is enabled, the AM depth measurement is always a corrected measurement.

If % CAL FACTOR (Blue Key, MHz) is selected, and the AM calibration factor is enabled, the AM calibration factor is displayed. If % CAL FACTOR (Blue Key, MHz) is selected, and the AM calibration factor is disabled, 100% is displayed. (Note the resolution of 1%.)

Calibrating Another RF Signal Analyzer.

The Measuring Receiver displays the computed AM depth (Special Function 13.0), but shows two dashes (--) throughout the rest of the procedure.

MEASUREMENT TECHNIQUE

When AM and then CALIBRATE are selected, the FM Calibrator sends an unmodulated 10.1 MHz carrier to the AM Calibrator.

The AM Calibrator contains two identical modulators in parallel whose outputs are summed. When the calibration operation is initiated, each modulator is turned on and each individual output level is measured, via an on-board detector, to compute AM depth.

While one of the modulators is on, the residual AM of the calibrator (very low) and the AM demodulator (more significant) are characterized and weighted (refer to *Residual Noise Effects* on page 3-219). Next, one modulator is left on and the other is toggled on and off at a 10 kHz rate. Since the RF signal is switched between full on and half on, the resultant carrier modulation is very near 33.33%. (The exact depth is derived from the measurements that characterize the individual modulators.) This modulation is then measured by the AM demodulator. (Both peak detectors are used, and their average is computed.)

The Measuring Receiver compares the modulation depth (static measurements) with the demodulated AM (toggled measurements) and computes its accuracy error as follows:

$$AM\ Calibration\ Factor\ (\%) = \frac{Demodulated\ AM - Demodulated\ Residual\ AM}{Computed\ AM} \times 100$$

All segments of the calibration are carefully monitored. If any segment is out of limits, the calibration is aborted and Error 08 is displayed.

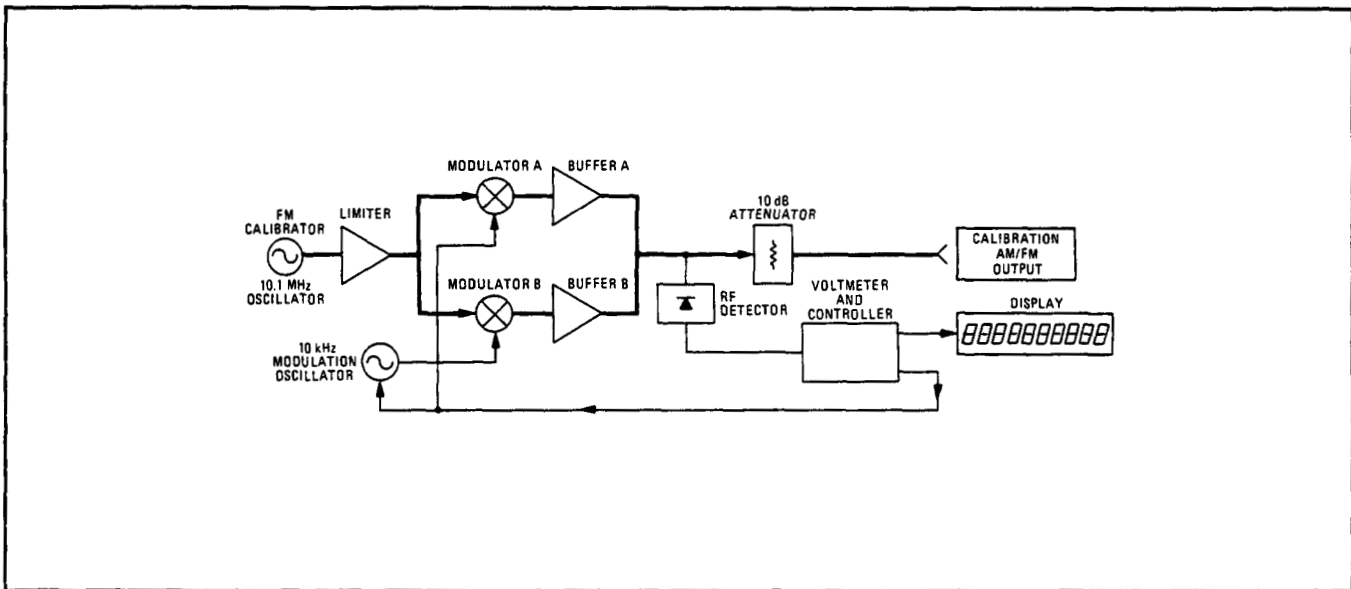

Simplified Block Diagram of the AM Calibrator

COMMENTS

Default Calibration Factor

If the instrument's non-volatile memory is erased, 100.00% is used as the default calibration factor.

Updating the AM Calibration Factor

Whenever AM calibration is performed, the instrument updates the stored AM calibration factor.

Special Function Cancellation

Performing Calibration cancels most special functions.

When Using the AM Calibrator to Calibrate Other Signal Analyzers

The modulation waveform of the AM Calibrator is a rounded squarewave. An RF signal analyzer, which uses it as a calibration standard, must have demodulation and audio-processing circuits which preserve the full fidelity of the waveform.

Automatic AM Ranging

When used to calibrate an RF signal analyzer, Special Functions 13.1 and 13.2 set the AM modulation range to that of 0 to 100% (Special Function 2.1). Upon exiting the AM Calibrator Special Function, the audio ranging is not returned to automatic but remains fixed (thus leaving the SPCL light on). Key in 2.0 SPCL to return the audio ranging to automatic.

AM Output

CAUTION

Do not apply greater than 10 V_{pk} (ac+dc) into the rear-panel AM OUTPUT connector or damage to the instrument may result.

DESCRIPTION

The rear-panel AM OUTPUT (dc coupled, 10 k Ω output impedance) provides an auxiliary output for the AM demodulated from the RF input signal. This output enables monitoring of AM during display of other measurements (such as FM, Φ M, or audio signals).

The output can also be used in conjunction with Special Function 6.2 (described in *AM ALC Response Time* on page 3-165) to measure AM depth at low modulation rates.

The output signal comprises both a dc voltage (related to the detected IF level) and an ac voltage (bandwidth 16 kHz, one pole proportional to the AM depth). The dc component contains an offset voltage (V_{off}) which must be subtracted out. The relationship between % AM and the signal levels at AM OUTPUT is:

$$\% AM = \frac{V_{pk}}{|V_{dc} - V_{off}|} \times 100\%$$

where: V_{pk} is the peak of the ac component,
 V_{dc} is the total dc component, and
 V_{off} is the dc offset voltage.

When the AM ALC is on, the dc level at AM OUTPUT is held constant, thus,

$$\% AM = K \times V_{pk},$$

where:

$$K = \frac{100\%}{V_{dc} - V_{off}}$$

When the AM ALC is turned off (Special Function 6.2), the dc voltage at AM OUTPUT varies with the signal level (although the offset remains constant), and the full formula must be used for each measurement.

PROCEDURE

To measure AM depth via AM OUTPUT, first determine the offset voltage:

Select AUTOMATIC OPERATION to clear any Special Functions in effect, then connect a dc voltmeter to the AM OUTPUT connector and remove any signal at RF INPUT. Press MHz to fix the tuning, and read the offset voltage on the voltmeter.

Disable the AM ALC loop (6.2 SPCL) and apply the carrier to the RF INPUT. Measure the dc and peak ac signals at AM OUTPUT. Use the first equation in "DESCRIPTION" to compute % AM.

EXAMPLE

To measure AM depth at AM OUTPUT with the AM ALC turned off, measure V_{off} first:
Remove any signal at the RF INPUT and connect a dc voltmeter to AM OUTPUT.

<p>LOCAL (keystrokes)</p>	<p>AUTOMATIC OPERATION</p> <p>MZ</p> <p>INPUT FREQ</p>
<p>↔ HP-1B ↔</p> <p>(program codes)</p>	<p>AUMZ</p>

For this example, assume the voltmeter reads an offset voltage of -0.36 Vdc. Connect an AM signal to the RF INPUT and tune the Measuring Receiver. Disable the AM ALC by selecting 6.2 SPCL.

Measure the dc voltage at AM OUTPUT. (When low AM rates are used, it is easiest to measure the dc voltage at AM OUTPUT before the modulation is applied.) For this example, assume the voltmeter reads -0.46 Vdc. Measure the peak ac voltage at AM OUTPUT (for low rates an oscilloscope may be necessary). For this example, assume 0.02 Vpk was measured on an oscilloscope. The % AM is:

$$\% AM = \frac{V_{pk} \times 100\%}{|V_{dc - off}|} = \frac{0.02 \times 100\%}{|(-0.46) - (-0.36)|} = 20\% AM$$

BLOCK DIAGRAM

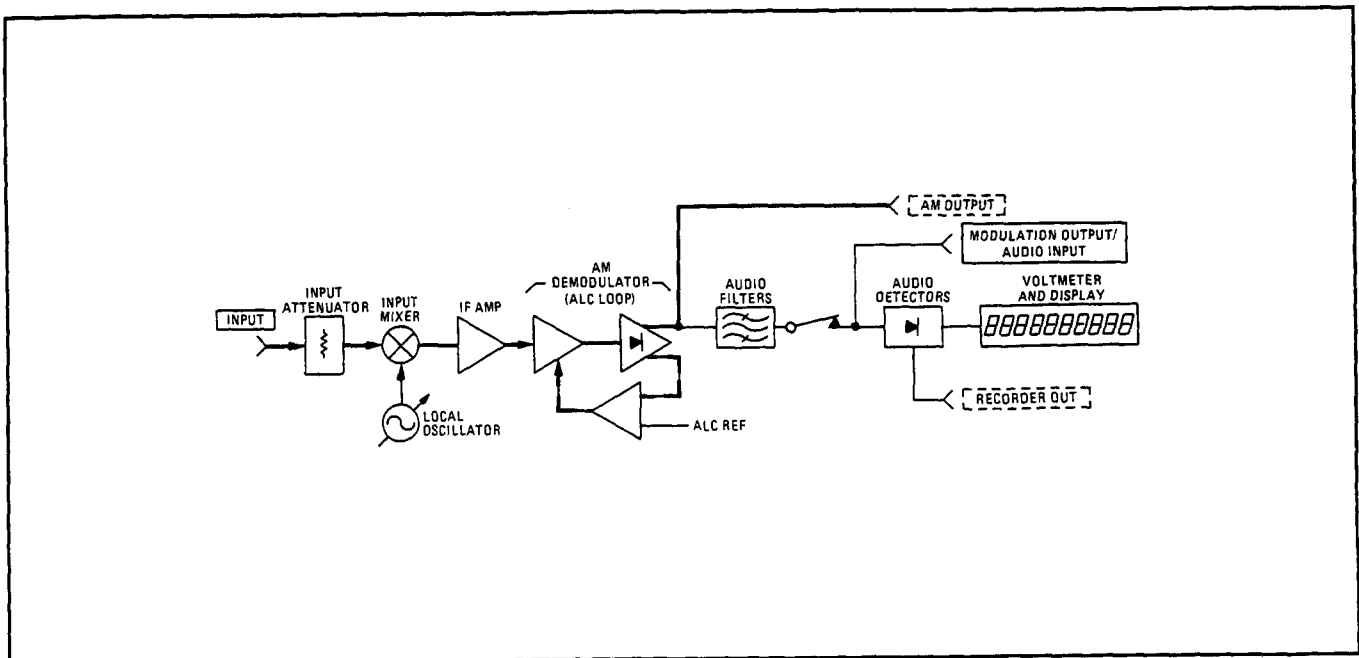

AM Output Block Diagram

COMMENTS

Inherent IF Component

AM OUTPUT contains a significant IF component which is greatest when operating at a carrier frequency of 150 kHz.

RF Peak Detector Measurements of AM Output

The accuracy of measurements made on the AM OUTPUT signal could be degraded if RF level measurements are made using the RF peak detector (Special Function 35.0).

FM

FUNCTIONS

FM, Special Function 2 (Audio Range)

DESCRIPTION

The Measuring Receiver can measure the FM deviation of the tuned input signal. (Special Function 2 enables the instrument to set limits on the range of FM deviation that can be measured.)

FM Measurements are specified for rates from 20 Hz to 10 kHz for carrier frequencies 10 MHz and below (or whenever the 455 kHz IF is used) and from 20 Hz to 200 kHz for carrier frequencies from 10 to 1300 MHz (1.5 MHz IF only). The corresponding 3 dB audio bandwidths are approximately 0.5 Hz to 15 kHz for carriers 10 MHz and below (or with the 455 kHz IF) and approximately 0.2 Hz to 260 kHz for carriers from 10 to 1300 MHz (1.5 MHz IF only). Peak deviations up to 40 kHz can be measured on carriers below 10 MHz, and peak deviations up to 400 kHz can be measured on carriers above 10 MHz.

The demodulated signal's frequency and distortion can also be measured. (Refer to *Audio Measurements* on page 3-225.)

PROCEDURE

To make an FM measurement, first tune the instrument to the input signal by selecting Automatic Operation. Press the FM key.

Select an audio detector: PEAK+, PEAK-, PEAK \pm /2, AVG, or RMS. (The RMS detector, selected by pressing the Blue Key and AVG key, is accurate in measuring FM, has a reduced bandwidth, and is usually only used for less audio distortion measurements.)

The following table lists the different measurement range limits that can be selected with Special Function 2

Modulation Range (Peak \pm kHz dev.)	Detector Selected	Special Function Code	Program Code ↔ HP-IB ↔	Display Resolution (Hz)	MODULATION OUTPUT Sensitivity (Vac/% Hz)
Automatic Selection		2.0 SPCL	2.0SP	Automatic Selection	
≤ 0.04	RMS	2.4 SPCL ¹	2.4SP	0.01	100
≤ 0.4	RMS Pk, Avg Pk, Avg, RMS	2.4 SPCL 2.4 SPCL ¹ 2.1 SPCL ¹	2.4SP 2.4SP 2.1SP	0.1	10
≤ 4	Pk, Avg Pk, Avg, RMS Pk, Avg, RMS	2.4 SPCL 2.1 SPCL 2.2 SPCL ¹	2.4SP 2.1SP 2.2SP	1	1
≤ 40	Pk, Avg, RMS	2.2 SPCL 2.3 SPCL ¹	2.2SP 2.3SP	10	0.1
≤ 400	Pk, Avg, RMS	2.3 SPCL	2.3SP	100	0.01

¹ With 750 μ s de-emphasis, pre-display only.

To filter the demodulated signal, press the appropriate filter keys. (Refer to *Filters, Audio* on page 3-207 for more information about filters.) If de-emphasis equalization is desired, select the appropriate time constant and display placement. (Refer to *FM De-emphasis* on page 3-187 for more information about filters.)

EXAMPLE

To measure the positive peak deviation of a signal in a 50 Hz to 15 kHz post-detection bandwidth and to place a 750 μ s time constant de-emphasis before the display:

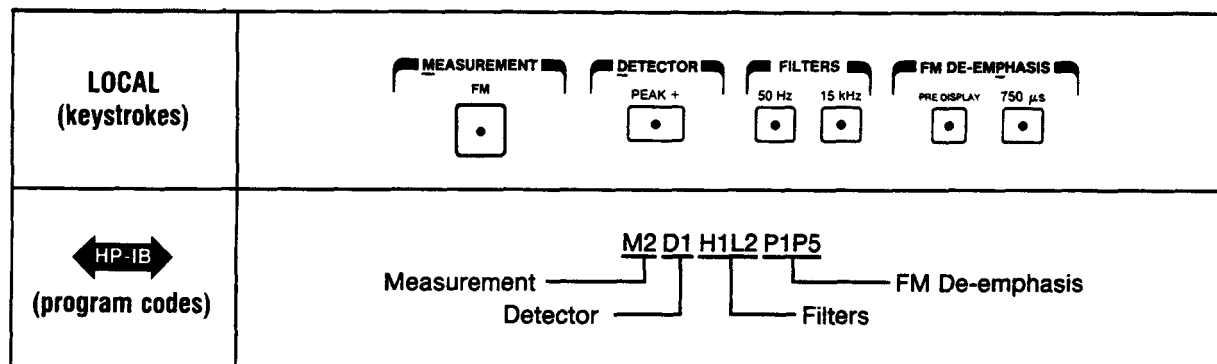

HP-IB PROGRAM CODES

All HP-IB codes for setting range limits for FM measurements are provided in "Procedures".

FM = M2

SPCL = SP

MEASUREMENT TECHNIQUE

The FM on the IF is demodulated by a frequency discriminator. The amplitude of the discriminator's output is proportional to the frequency deviation. The demodulated signal is filtered, audio detected, and displayed as kHz deviation.

FM de-emphasis equalization can be inserted ahead of the audio detectors and display circuitry by selecting PRE DISPLAY. The demodulated FM signal always passes through the FM de-emphasis "network" before it appears at the output of MODULATION OUTPUT/AUDIO INPUT.

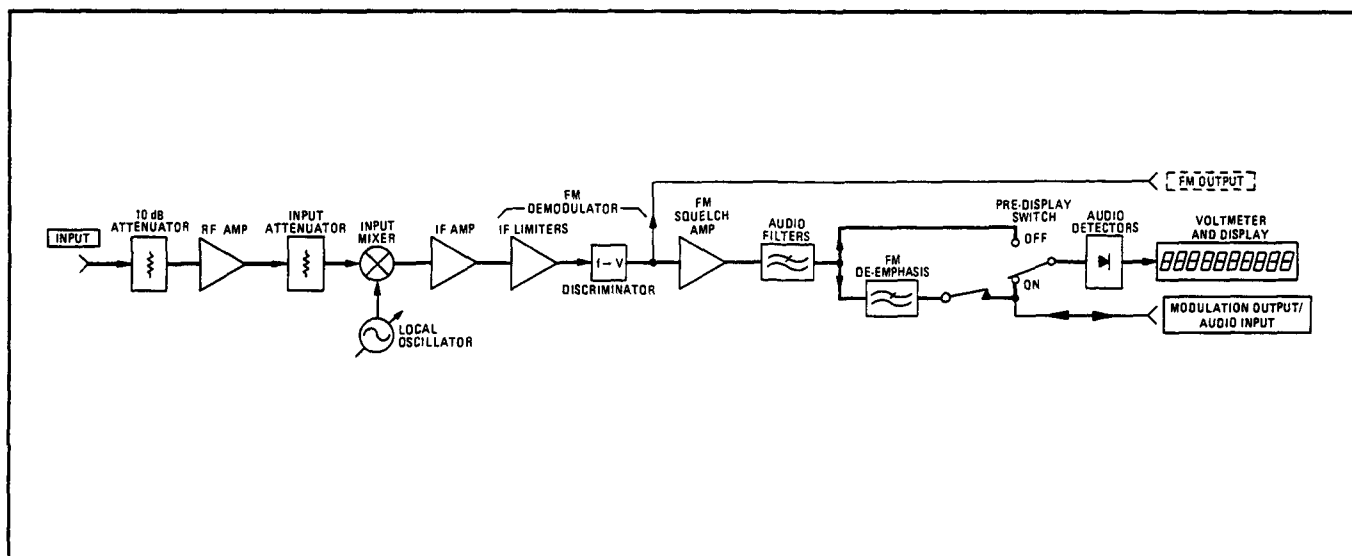

FM Measurement Block Diagram

COMMENTS

Input/Output Status.

The demodulated FM is present at MODULATION OUTPUT/AUDIO INPUT (unless AUDIO INPUT has been selected). The demodulated FM is usually present at the rear-panel FM OUTPUT connector. If the RF input signal drops too low for accurate FM demodulation, the FM measurement is automatically squelched (muted, turned off) except for the FM OUTPUT. (Refer to *FM Output* on page 3-191.)

Relative FM Deviation Measurements.

If FM deviation is to be displayed relative to a reference, enter the value as a ratio reference using the RATIO key. (Refer to *Ratio* on page 3-245.)

Peak \pm /2 Detector.

The PEAK+ detector always detects the upward carrier frequency excursion while the PEAK– detector always detects the downward carrier frequency excursion. The PEAK \pm /2 detector sums the upward and downward frequency-excursion readings and divides the total by two to provide an average of the two peak values. (Do not confuse this “average” value with the detected average value.)

Inverted Output Signals.

When operating with carrier frequencies below 2.5 MHz, the output signal at MODULATION OUTPUT/AUDIO INPUT is inverted unless the 455 kHz IF is selected. When operating with carrier frequencies above 2.5 MHz or when using the 455 kHz IF, the signal at FM OUTPUT is inverted.

Automatic Range Selection.

The routine which automatically selects the modulation range contains regions of overlap between the following displayed peak deviations:

0.35 and 0.4 kHz (750 μ s de-emphasis, pre-display only), 3.5 and 4 kHz, and 35 and 40 kHz.

When using the average or RMS detector, ranging will occur at readings lower than these. In general, if the modulation is reduced from a higher range into an overlap region, the range does not change. To range the display for increased resolution, press the FM key a second time. To set the instrument to a selected modulation range, refer to Audio Range.

Default Condition.

When the Measuring Receiver is first powered up, demodulated FM, with a sensitivity of 0.01 Vpk/MHz (400 kHz peak deviation range), is available at MODULATION OUTPUT/AUDIO INPUT. The instrument does not autorange to more sensitive ranges because the Frequency Measurement mode has been automatically selected, which automatically disables Error 04 (audio circuits overdriven). When Error 04 is disabled, the instrument only autoranges to less sensitive audio ranges.

Increased Accuracy.

Accuracy of FM readings may be improved by using the FM Calibrator (refer to *FM Calibration* on page 3-181) and by taking into account the effects of residual noise (refer to *Residual Noise Effects* on page 3-219).

Automatic Squelching.

If the RF input signal drops too low for accurate FM demodulation, the FM measurement is automatically squelched (muted, turned off). In the 8902A Measuring Receiver, RF gain can be inserted into the RF signal path or IF gain can be inserted into the IF path to raise the signal to the level required for measurement.

Potential Inaccuracies.

AM conditions that cause the carrier signal to disappear (such as 100% AM or pulse modulation) will cause inaccuracies in measurement of FM, Φ M, or input frequency, or they could cause Error 05 (FM squelched) to be displayed when these measurements are selected.

Considerations When Using the RMS Detector

During FM measurements if the RMS detector is selected (Blue Key, AVG), FM de-emphasis pre-display is automatically selected. Pre-display must turn on at this time due to circuit configuration of the Measuring Receiver. When pre-display is selected this way, it will not turn off automatically when another detector is selected. Turn off pre-display (after selecting another detector) by pressing the PRE DISPLAY key (HP-IB code: P0). Measurements could be affected by this pre-display selection.

FM Calibration

FUNCTIONS

CALIBRATE, SAVE CAL, Function 12 (FM Calibration), Special Function 17 (FM Calibration Factor)

DESCRIPTION

The accuracy of the Measuring Receiver's FM demodulator can be checked with the internal FM calibrator. The calibration process generates a calibration factor to compensate for the FM measurement error (within the accuracy limits of the FM Calibrator). The calibration factor can then be enabled to automatically correct the measured FM error in subsequent measurements using the SAVE CAL key or Special Function 17. With the calibration factor enabled, FM measurements can be made with an accuracy typically better than 0.5%. The calibration factor can be enabled, disabled, or displayed at any time.

Other instruments in the HP 8901 and 8902 RF signal analyzer family can be calibrated or cross checked with the Measuring Receiver's FM calibrator using Special Function 12.

PROCEDURE

Self-Calibration.

To determine the measurement error of the Measuring Receiver's FM demodulation circuits, first allow at least a half-hour continuous operation before calibration, then perform the following steps:

1. Connect the CALIBRATION AM/FM OUTPUT to the RF INPUT with a 50 Ω cable (or a sensor module with an internal switch such as the HP 11722A) and select FM.
2. Press the CALIBRATE key. After several seconds, the FM calibration factor is displayed in % and stored (but not enabled unless already enabled).

The instrument displays 100.00% if no error is measured. A display of 100.17% means the FM demodulator in the Measuring Receiver is reading 0.17% high. As long as the CALIBRATE key light is on and the cable is connected, calibration repeats and the FM calibration factor is updated approximately every 17 seconds. To turn off the calibrator, select CALIBRATE or any Measurement key.

NOTE

For optimum accuracy, the instrument should be continuously operating for at least one half hour before calibration is performed. In addition, the first two FM Calibration Factors received after instrument power-up should not be used even if the instrument is already warm, since the circuits in the audio chain may not be fully settled.

Correcting Measurements with the FM Calibration Factor.

Once a calibration factor has been determined, the instrument retains that value in its non-volatile memory. This factor can be enabled to automatically correct FM measurements. The calibration factor can also be disabled or displayed.

Selecting % CAL FACTOR (Blue Key, MHz) or 16.2 SPCL displays the Calibration Factor being used.

Enter the appropriate front-panel key or special function code to manipulate the FM Calibration Factor as described in the following table:

Action: FM Calibration Factor	Measurement Mode	Front-Panel Key or Special Function Code	Program Code 
Disable	Any	17.0 SPCL	17.0SP
Enable	FM (From CALIBRATE mode)	(Blue Key) SAVE CAL	SC
	Any	17.1 SPCL	17.1SP
Display	FM	(Blue Key) % CAL FACTOR*	CF
	Any	17.2 SPCL	17.2SP

Calibrating or Cross Checking Another HP 8901 or 8902 RF Signal Analyzer.

To compute an FM calibration factor for another RF signal analyzer that has no internal calibrator, or that has an internal calibrator that is to be cross checked, use the Measuring Receiver and its calibrator as follows:

1. Connect the Measuring Receiver's CALIBRATION AM/FM OUTPUT to the RF input of the other RF signal analyzer.
2. Key in 12.0 SPCL into the Measuring Receiver. Record the value that appears in the display. This is the computed, calibrated, peak FM deviation (excluding noise).
3. Key in 12.1 SPCL into both instruments. Record the value that appears on the display of the RF signal analyzer. (If display jitter makes readings difficult, key in 5.1 SPCL.) The displayed value is the weighted, peak, residual FM deviation of the calibrator's unmodulated output as demodulated by the RF signal analyzer.
4. Key in 12.2 SPCL for both instruments. Record the value that appears on the display of the RF signal analyzer. (If display jitter makes readings difficult, select 5.1 SPCL.) The displayed value is the demodulated, positive, peak FM deviation of the calibrator's modulated output (including noise).
5. On the RF signal analyzer, select PEAK-. Note the value displayed on the RF signal analyzer. If the difference between the results of steps 4 and 5 is three counts or less in the least significant digit, an average between the two need not be computed; use the result from step 4. If the difference between the two readings is greater than three counts in the least significant digit, compute the average as follows:

$$(12.2 \text{ result}) = \frac{(\text{result of step 4}) + (\text{result of step 5})}{2}$$

6. Compute the FM calibration factor of the RF signal analyzer as follows:

$$FM \text{ Calibration Factor } (\%) = 100 \times \frac{(12.2 \text{ result}) - (12.1 \text{ result})}{(12.0 \text{ result})}$$

7. To use this FM calibration factor to correct FM measurements made with the RF signal analyzer, enter the value as a ratio reference and use the Ratio function in the RF signal analyzer.

The Special Function codes are summarized in the table below:

Function	Special Function Code	Program Code ← HP-IB →
Display computed peak FM	12.0 SPCL	12.0SP
Display demodulated peak residual FM	12.1 SPCL	12.1SP
Display demodulated peak FM	12.2 SPCL	12.2 SP

HP-IB PROGRAM CODES

HP-IB codes for enabling, disabling, or displaying the internal FM calibration factor are provided in "Procedures". The HP-IB codes for the FM Calibrator Special Function used to calibrate another RF signal analyzer are also provided as part of "Procedures".

FM = M2
 CALIBRATE on = C1
 CALIBRATE off = C0
 SPCL = SP

INDICATIONS

Self-Calibration.

When the CALIBRATE key is pressed, approximately 17 seconds pass during which the instrument configures itself and tunes to the calibrator's signal. The display indicates four dashes (----) and lights the % annunciator. Once the FM Calibration Factor has been computed, it is displayed. Subsequent updates occur approximately every 17 seconds.

Correcting Measurements with the FM Calibration Factor (Self-Calibrated).

When the calibration factor is enabled, the FM deviation measurement is always a corrected measurement.

If % CAL FACTOR is selected, and the FM calibration factor is enabled, the FM calibration factor is displayed. If % CAL FACTOR is selected, and the FM calibration factor is disabled, 100% is displayed. (Note the resolution of 1%.)

Calibrating Another RF Signal Analyzer.

The Measuring Receiver displays the computed FM deviation (Special Function 12.0), but shows two dashes (--) throughout the rest of the procedure.

MEASUREMENT TECHNIQUE

When FM is selected and CALIBRATE is selected, a 10.1 MHz voltage controlled oscillator (VCO) within the calibrator is driven to one end of its nominal tuning range. The frequency of the VCO is counted, and the oscillator is driven to the opposite end of its tuning range where it is counted again. The peak FM deviation is computed from these measurements.

While the VCO is at one end of its range, the residual FM of the calibrator (very low) and the FM Demodulator (more significant) are characterized and weighted. (Refer to *Residual Noise Effects* on page 3-219.) The VCO is frequency modulated by a 10 kHz modulation oscillator, and the FM demodulator makes another FM measurement. (Both peak detectors are used and the average is computed.)

The Measuring Receiver compares the deviation (static measurements) with the demodulated FM (toggled measurements) and computes its accuracy error as follows:

$$FM \text{ Calibration Factor } (\%) = \frac{\text{Demodulated FM} - \text{Demodulated Residual FM}}{\text{Computed FM}} \times 100$$

All segments of the calibration are carefully monitored. If any segment is out of limits, the calibration is aborted and Error 08 is displayed.

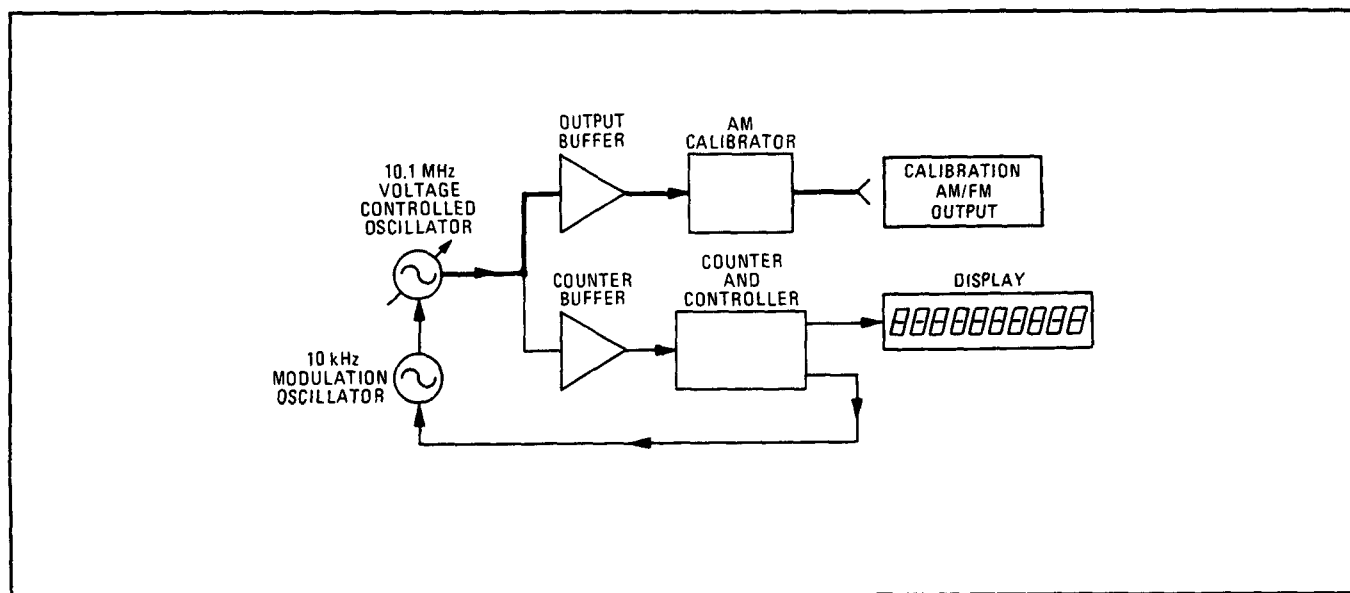

Simplified Block Diagram of the FM Calibrator

COMMENTS

Default Calibration Factor.

If the instrument's non-volatile memory is erased, 100.00% is used as the default calibration factor.

Updating the FM Calibration Factor.

Whenever FM calibration is performed, the instrument updates the stored FM calibration factor.

Special Function Cancellation.

Performing calibration cancels most Special Functions.

When Using the FM Calibrator to Calibrate Other Signal Analyzers.

The modulation waveform of the FM Calibrator is a rounded trapezoid. An signal analyzer, which uses it as a calibration standard, must have demodulation and audio processing circuits which preserve the full fidelity of the waveform.

Automatic FM Ranging.

When used to calibrate an RF signal analyzer, Special Functions 12.1 and 12.2 set the FM deviation range to that of 0 to 40 kHz (Special Function 2.2). Upon exiting the FM Calibrator Special Function, the audio ranging is not returned to automatic but remains fixed (thus leaving the SPCL light on). Key in 2.0 SPCL to return the audio ranging to automatic.

FM De-emphasis

FUNCTIONS

Pre-Display, 25 μ s, 50 μ s, 75 μ s, 750 μ s

DESCRIPTION

The de-emphasis networks equalize the pre-emphasis often encoded on broadcast FM signals. This type of equalization provides a simple means of reducing audible noise on FM communication systems. Pre-emphasis gives a 6 dB per octave, high-frequency boost to the baseband audio before modulating the carrier. De-emphasis reverses the boost after demodulation at the receiver. The 3 dB corner of the pre-emphasis or de-emphasis network is usually expressed as a time constant. The relationship between the time constant, τ_o , and the 3dB corner frequency, f_o , is $f_o = \frac{1}{2} \pi \tau_o$.

The 3dB corner frequencies of the de-emphasis equalizers (typically accurate to $\pm 3\%$) are listed in the following table:

FM De-emphasis	
Time Constant (μ s)	3 dB Frequency (Hz)
25	6366
50	3183
75	2122
750	212.2

PROCEDURE

To add de-emphasis to the demodulated FM, select the key corresponding to the desired time constant. (Unless AUDIO INPUT has been selected, the de-emphasized FM is available at the MODULATION OUTPUT/AUDIO INPUT.) To also display the de-emphasized FM, select PRE DISPLAY.

HP-IB

In local operation, to turn off one of the de-emphasis functions, press the lighted key a second time. In remote operation, turn the equalizers off with code PO. (HP-IB code PO also turns off the PRE DISPLAY function.)

EXAMPLE

To measure the positive peak FM deviation of a carrier with 750 μ s de-emphasis inserted before the deviation measurement:

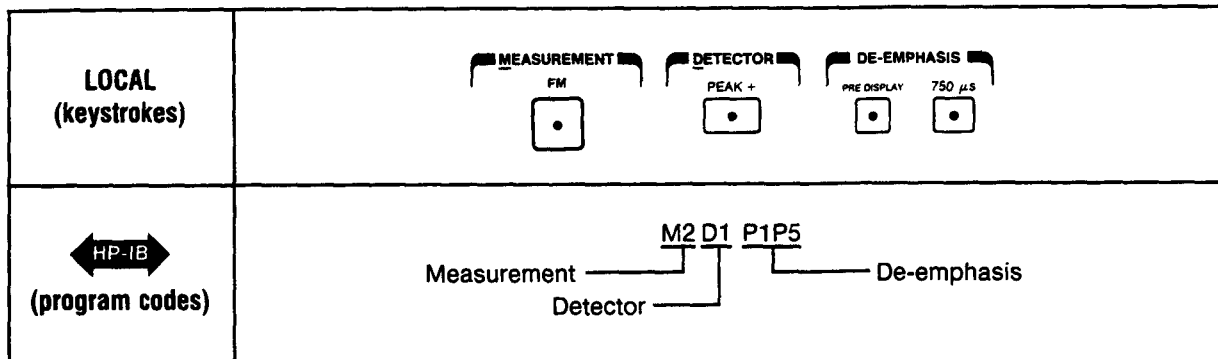

HP-IB PROGRAM CODES

FM De-emphasis		
Time Constant (μ s)	PRE DISPLAY On	PRE DISPLAY Off
Filters off	P0P1	P0
25	P1P2	P0P2
50	P1P3	P0P3
75	P1P4	P0P4
750	P1P5	P0P5

COMMENTS

Input/Output Status.

When selected, the de-emphasis networks are inserted in the audio signal path following the audio filters. They will affect the output signal at MODULATION OUTPUT/AUDIO INPUT and can be placed before the audio detector and display. (Refer to the block diagram in FM.) De-emphasis has no affect on the rear panel FM Output.

When Measuring Low Deviation FM

When 750 μ s de-emphasis is selected, FM sensitivity at the MODULATION OUTPUT/AUDIO INPUT is increased by a factor of ten. The range of deviation measurements is restricted to 40 kHz peak deviation or less after de-emphasis. The display resolution, however, remains the same as without de-emphasis unless the pre-display mode has been selected at which time the display resolution increases ten times. This feature provides greater resolution for measuring low deviation FM.

HP-IB. Automatic Selection of Pre-Display.

When the true rms detector is selected, the pre-display mode for FM de-emphasis is automatically enabled. This is true whether FM has been selected or not. (Selection of the FM de-emphasis time constant, however, remains unaffected.) The pre-display mode remains enabled until deliberately disabled. This idiosyncrasy is important to remember when programming the instrument via HP-IB.

Considerations When Using the RMS Detector

During FM measurements if the RMS detector is selected (Blue Key, AVG), FM de-emphasis pre-display is automatically selected. Pre-display must turn on at this time due to circuit configuration of the Measuring Receiver. When pre-display is selected this way, it will not turn off automatically when another detector is selected. Turn off pre-display (after selecting another detector) by pressing the PRE DISPLAY key (HP-IB code: P0). Measurements could be affected by this pre-display selection.

FM Output

CAUTION

Do not apply greater than 10 V_{pk} (ac + dc) into the rear-panel FM OUTPUT connector or damage to the instrument may result.

DESCRIPTION

The rear-panel FM OUTPUT (dc-coupled, 10 kΩ output impedance) provides an auxiliary output for the FM demodulated from the RF input signal. This output enables monitoring of FM during display of other measurements (such as AM, ΦM, or audio signals) or when the modulation rate is very low.

The output signal comprises both a dc voltage, related to the counted IF frequency, and an ac voltage (bandwidth 16 kHz, one pole) proportional to the FM deviation.

With the input signal centered in the IF, the nominal dc offset voltage at FM OUTPUT is approximately 0.8 V_{dc} for the 1.5 MHz IF and -5.6 V_{dc} for the 455 kHz IF. The FM sensitivity is typically 6 V/MHz or 6 mV/kHz. The dc voltage at FM OUTPUT can be calculated as follows:

$$V_{dc} = V_{off} - \frac{(K)(FREQ\ ERROR)}{1000}$$

where: V_{dc} = representation of the dc voltage at FM OUTPUT volts,
 V_{off} = representation of the dc offset voltage for the IF used volts,
 K = the FM sensitivity in mV/kHz, or V/MHz, and
 FREQ ERROR = the kHz error displayed when FREQ ERROR is selected.

Measure V_{off} when the frequency error is 0 kHz. The sensitivity can be measured using the following procedure:

PROCEDURE

To determine the sensitivity of the FM OUTPUT, apply an unmodulated 2 MHz carrier at the RF INPUT. (Select 3.2 SPCL, which uses the 1.5 MHz IF described in *Filters, RF and IF* on page 3-259). Measure the dc voltage at the output with a dc voltmeter. Move the carrier to 1 MHz and again note the dc voltage. The FM sensitivity (K in V/MHz or mV/kHz) is:

$$K = (V_{dc} \pm 2\ MHz) - (V_{dc} \pm 1\ MHz)$$

EXAMPLE

A 2 MHz unmodulated signal is applied to the RF INPUT. A dc voltmeter connected to FM OUTPUT measures +3.89 V_{dc}. When the carrier is set to 1 MHz, -2.272 V_{dc} is measured. The FM sensitivity is:

$$(3.890) - (-2.272) = 6.162\ V/MHz\ or\ 6.162\ mV/kHz$$

BLOCK DIAGRAM

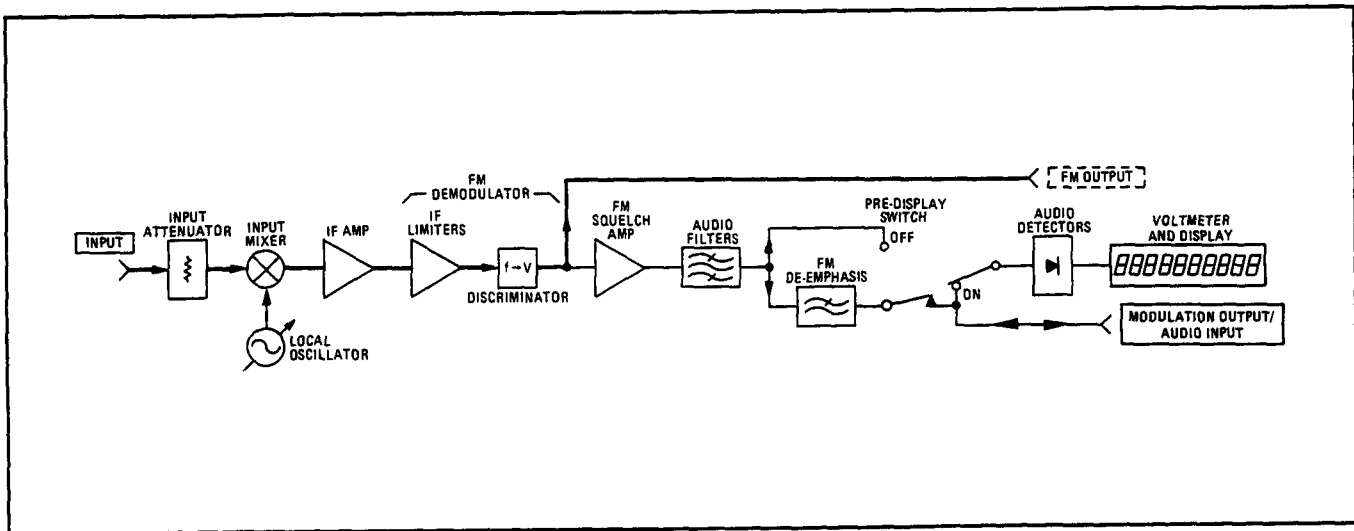

FM Output Block Diagram

COMMENTS

Inherent IF Component.

FM OUTPUT is unsquelched and also contains a significant component at twice the IF frequency which is greatest when operating at a carrier frequency of 150 kHz.

Inverted AC Output Component.

Note that the sense of the ac output component (corresponding to the demodulated FM) is inverted for carriers above 2.5 MHz.

Accuracy of Output During RF Level Measurements.

When RF Level measurements (Special Function 35) are made, automatic selection of RF input attenuation and gain overrides any manual settings that might have been selected with Special Function 1. The selected attenuation could degrade the accuracy of measurements made on the FM OUTPUT signal.

Tone-Burst Receiver

FUNCTIONS

Special Function 18 (Tone-Burst Receiver)

DESCRIPTION

In some FM applications (mobile radio testing, for example), after a transmitter is keyed, it issues squelch tones for a brief interval. Often, it is necessary to measure the frequency of the squelch tones. This measurement is made difficult by the noise in the demodulated audio during the short delay between the keying of the transmitter and the appearance of the audio tones.

Special Function 18 enables the Measuring Receiver to be configured as a tone-burst receiver. This function inserts a user-selectable delay between the instant the instrument senses an RF signal at its RF INPUT and the time when it turns on the output of MODULATION OUTPUT/AUDIO INPUT. When an external counter is connected to this output, the squelch tone will reach the counter only when a valid measurement can be made. The time delay is selectable from 1 through 99 milliseconds. The following photo illustrates a 99 ms delay between transmitter keying (lower trace).

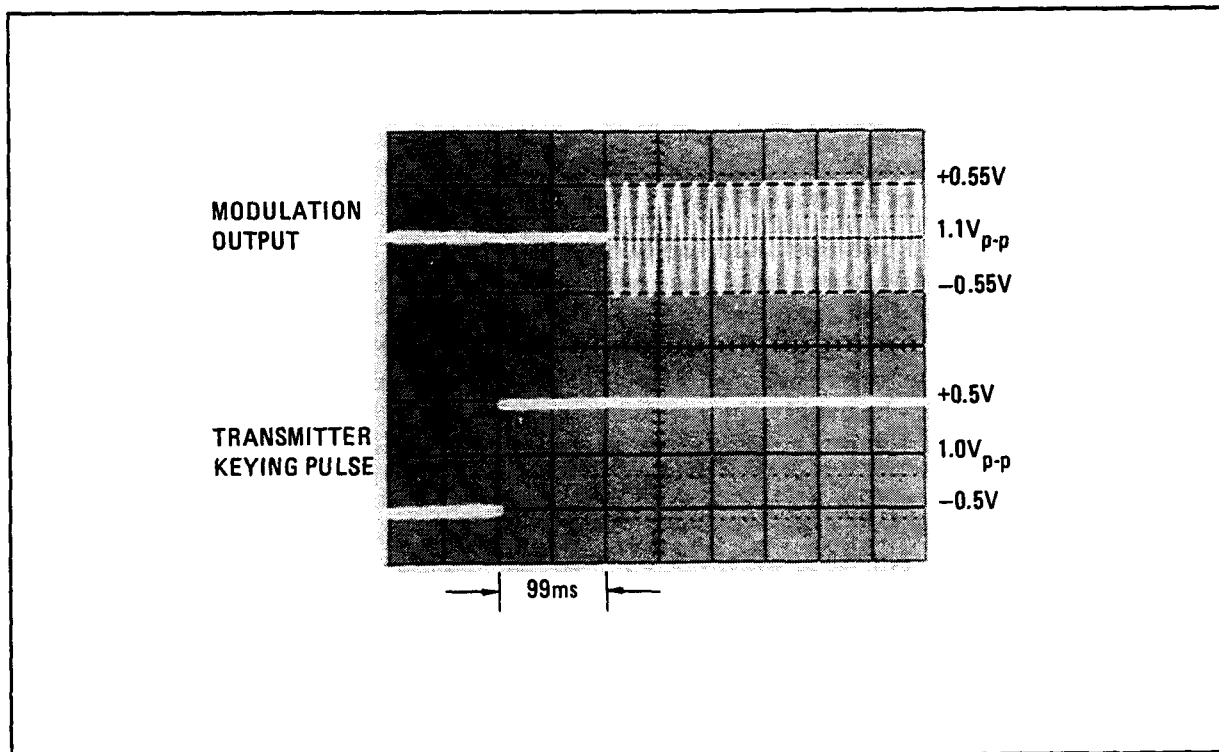

Oscilloscope Photo Depicting a 99 ms Delay Between Transmitter Keying Pulse (Lower Trace) and Activation of MODULATION OUTPUT/AUDIO INPUT

PROCEDURE

In order to successfully measure tone bursts, tune and range the Measuring Receiver:

1. Select FM.
2. Select an audio detector and if desired, audio filters and FM de-emphasis.
3. Key on the transmitter and allow the Measuring Receiver to range and tune automatically.
4. Select RANGE HOLD to hold all ranges and tuning.
5. Select the time delay to be inserted between the moment the transmitter is keyed and the time MODULATION OUTPUT/AUDIO INPUT is to be turned on. This delay becomes the Special Function suffix. (If 18.0 SPCL is selected, the Measuring Receiver executes a 99 ms delay.)
6. Enter the Special Function code 18.NN (where NN is the selected delay in milliseconds), then select SPCL. (If 18.5 is entered, a 5 ms delay is executed. For a 50 ms delay, enter 18.50.)

The Measuring Receiver is now initiated to receive tone bursts. To exit this mode, select any key except the Blue Key, S (shift), or LOCAL Key, or numeric keys.

PROGRAM CODES

The Special Function code suffix is derived from the time delay as described in "PROCEDURE".

SPCL = SP

INDICATIONS

As the numeric code is entered, it appears on the front panel display. When the SPCL key is pressed, 18.NN is displayed (NN is the delay in milliseconds). If no RF is at the RF INPUT connector, two dashes (--) are displayed.

COMMENTS

Suggested Use of Maximum Delay.

When using the Tone Burst Receiver Special Function, use the 99 ms delay for best results. Shorter delays require very careful setup since, with no input, the high-gain IF Amplifier and Limiters "tune" the noise to an average frequency often slightly different than the nominal IF. When RF first enters the instrument, the IF shifts abruptly to the nominal frequency. This shift creates an FM transient which settles out after a short period and thus is not apparent with longer delays. With short delays the transients can be avoided by carefully tuning the instrument so that the IF frequency when the transmitter is on is close to, or equal to the average IF frequency when the transmitter is off.

HP-IB.

This function is best used when operating via HP-IB since the external counter connected to the output of MODULATION OUTPUT/AUDIO INPUT may need to acquire several sets of data in rapid succession (when counting multiple tones, for example).

Selective Range Holding.

Ranges can be held for this function using the individual Special Functions for each parameter instead of using the Range Hold key.

Default Condition.

Special Function code 18.0 provides a 99 ms delay.

Tone Burst Frequency Cannot Be Measured.

The audio frequency measurement mode cannot be used to measure the frequency of the tone burst.

Φ M But Not AM.

This feature works also with the Φ M measurement mode but not AM.

Φ M

FUNCTIONS

Φ M, Special Function 2 (Audio Range)

DESCRIPTION

The Φ M key enables the Measuring Receiver to measure the phase deviation of the tuned input signal. The demodulated Φ M is present at MODULATION OUTPUT/AUDIO INPUT.

The Φ M measurement is specified only for RF carriers from 10 to 1300 MHz; however, Φ M measurements can be performed on carriers from 150 kHz to 10 MHz.

The Φ M measurement is only specified for modulation rates from 200 Hz to 20 kHz; however, the low frequency 3 dB limit is typically 7 Hz.

The following figure shows the display resolution for different combinations of peak phase deviation and modulation rate.

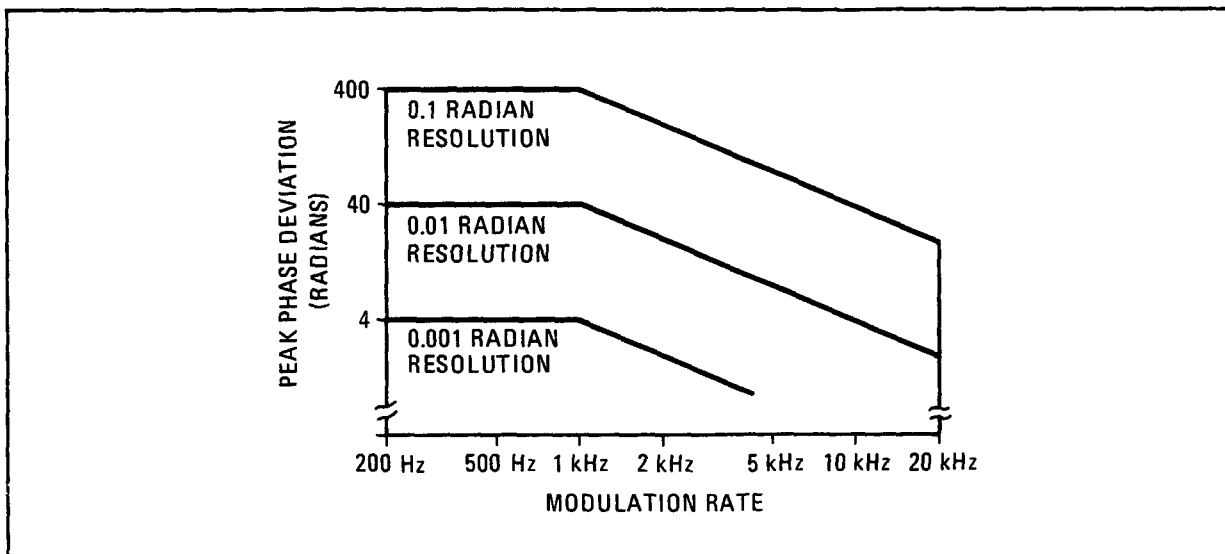

PROCEDURE

To make a Φ M measurement, first tune the instrument to the input signal by selecting AUTOMATIC OPERATION. Select Φ M.

Select an audio detector: PEAK+, PEAK-, PEAK \pm /2, AVG, or RMS. (The RMS detector, selected by pressing the Blue Key and the RMS key, is less accurate in measuring Φ M and is typically only used for audio distortion measurements.)

The following table lists the different measurement range limits that can be selected with Special Function 2:

Modulation Range (Peak ± rad. dev.)	Detector Selected	Special Function Code	Program Code ↔ HP-IB ↔	Display Resolution (radians)	MODULATION OUTPUT Sensitivity (mVac/radian)
Automatic Selection		2.0 SPCL	2.0SP	Automatic Selection	
≤0.4	RMS	2.4 SPCL	2.4SP	0.0001	10
≤4	Pk, Avg	2.4 SPCL	2.4SP	0.001	1
≤4	Pk, Avg, RMS	2.1 SPCL	2.1SP	0.001	1
≤40	Pk, Avg, RMS	2.2 SPCL	2.2SP	0.01	0.1
≤400	Pk, Avg, RMS	2.3 SPCL	2.3SP	0.1	0.01

To filter the demodulated signal, select the appropriate filter keys. (Refer to *Audio Filters* on page 3-207 for more information about filters.)

EXAMPLE

To measure the positive-peak phase deviation of a signal in a 50 Hz to 15 kHz post-detection bandwidth:

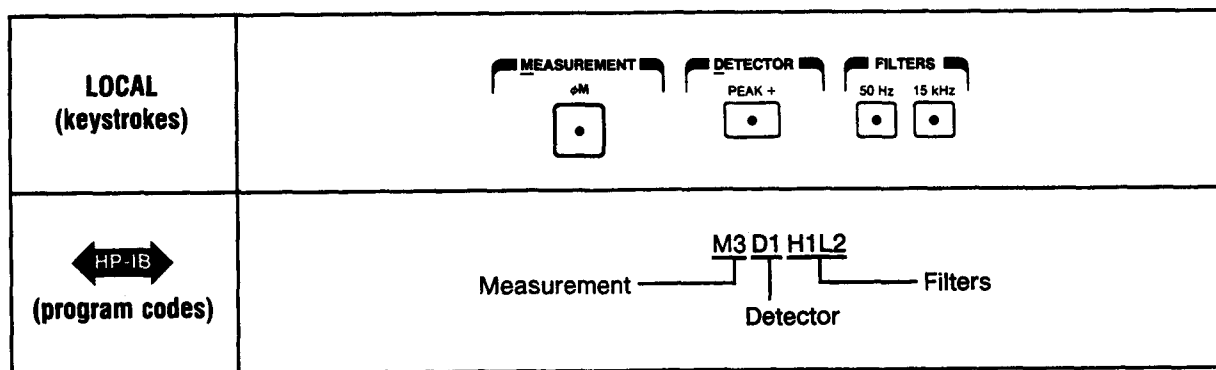

HP-IB PROGRAM CODE

All HP-IB codes for setting range limits for ΦM measurements are provided in "Procedures".

ΦM = M3

MEASUREMENT TECHNIQUE

The Φ M on the IF is first demodulated by a frequency discriminator. The amplitude of the discriminator's output is proportional to the frequency deviation. The demodulated signal is filtered and passed through an integrator, which extracts the phase information. The integrator's output is detected and displayed as phase deviation in radians. The integrator's output is made available at the MODULATION OUTPUT/AUDIO INPUT.

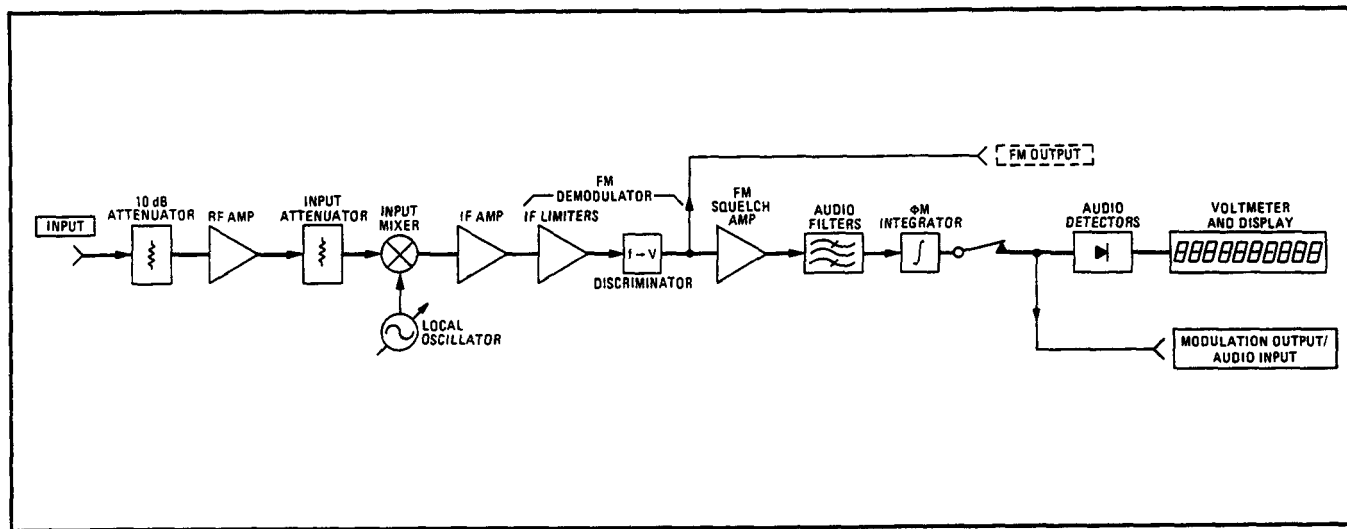

Φ M Measurement Block Diagram

COMMENTS

Frequency and Distortion Measurements.

The demodulated signal's frequency and distortion can also be measured. (Refer to *Audio Measurements* which begins on page 3-225.)

Relative Measurements.

If Φ M deviation is to be displayed relative to a reference, enter the value as a ratio reference using the RATIO key. (Refer to *Ratio* on page 3-245.)

Peak Detector. The PEAK+ detector always detects the upward carrier phase excursion while the PEAK- detector always detects the downward carrier phase excursion. The PEAK \pm /2 detector sums the upward and downward phase-excursion readings and divides the total by two to provide an average of the two peak values. (Do not confuse this "average" value with the detected average value.)

Inverted Output Signals.

When operating with carrier frequencies below 2.5 MHz, the output signal at MODULATION OUTPUT/AUDIO INPUT is inverted unless the 455 kHz IF is selected. When operating with carrier frequencies above 2.5 MHz or when using the 455 kHz IF, the upper limit of the modulation rate is that of the >20 kHz LP FILTER.

Automatic Range Selection.

The routine which automatically selects the modulation range contains regions of overlap between the following displayed peak deviations:

0.35 and .4 radians, 3.5 and 4 radians, and 35 and 40 radians.

When using the average or RMS detector, ranging will occur at readings lower than these. In general, if the modulation is reduced from a higher range into an overlap region, the range does not change. To range the display for increased resolution, press the ΦM key a second time. To set the instrument to a selected modulation range, refer to *Audio Range* on page 3-211.

Potential Inaccuracies.

AM depths approaching 100% cause the carrier to nearly disappear and may cause inaccurate measurement of ΦM deviation or Error 05 (FM squelched).

Input/Output Status.

When ΦM is selected, the signal at the rear-panel FM OUTPUT still represents demodulated FM, not ΦM .

Increased Accuracy.

Accuracy of ΦM readings may be improved by taking into account the effects of residual noise. (Refer to *Residual Noise Effects* on page 3-219.)

Phase Deviation in Degrees.

To display phase deviation in degrees instead of radians, enter 1.745 as a ratio reference and select RATIO. (Refer to *Ratio* on page 3-245.)

Pulsed Phase Modulation.

Pulsed phase modulation, such as phase shift keying, cannot be accurately demodulated or measured by the Measuring Receiver.

Recommended Filter Selection.

Because of the high sensitivity of the ΦM measurement to low-frequency audio (microphonics, hum, etc.), use of the 50 Hz or 300 Hz low-pass filter is recommended. (Neither is switched in automatically.)

Audio Detectors

FUNCTIONS

PEAK+, PEAK-, PEAK±/2, PEAK HOLD, AVG, RMS.

DESCRIPTION

The Measuring Receiver provides three types of audio detectors: peak responding, average responding (rms calibrated), and true rms. These three detectors provide six modes of audio measurements:

- Positive Peak (PEAK+)
- Negative Peak (PEAK-)
- Average of Positive and Negative Peaks (PEAK±/2 mode)
- Positive or Negative Peak Hold (PEAK HOLD)
- Average (AVG:RMS Calibrated)
- True RMS (RMS)

The two peak detector keys, when pressed individually, select whether the positive peak or the negative peak of the demodulated signal is measured. When the two peak detector keys are pressed simultaneously (the PEAK±/2 mode), the positive and negative peaks are averaged according to the following equation:

$$\text{Peak Average} = \frac{(\text{Peak+}) + (\text{Peak-})}{2}$$

Peak Hold detection is used in conjunction with positive or negative audio peak detector modes. This mode enables the instrument to hold and display indefinitely, the largest peak detected. This feature is useful for capturing the peak maximum of a modulation transient.

Average detection selects an average-responding detector that is calibrated to read the rms value of a sinewave.

True RMS detection selects a true rms detector to measure audio signals. Also, noise and residual measurements are best measured with the true rms detector. This detector is automatically selected and is the only one used with the external audio voltage measurement (Special Function 30), audio distortion measurement and the SINAD measurement (Special Function 29). Selection of this detector also affects the FM pre-display de-emphasis. (Refer to "COMMENTS".)

Once selected, a detector remains unchanged and is automatically activated each time modulation measurements are made until another detector is selected (except for the true rms detector as discussed in the previous paragraph). (However, once it is automatically selected, the true rms detector remains active.)

PROCEDURE

When a modulation measurement is selected, a detector is automatically activated.

To obtain a peak detector, select either PEAK+ or PEAK-. Press both keys simultaneously to enable the peak-average (PEAK \pm /2) mode.

Peak hold is used only with the peak detectors. Selecting PEAK HOLD initiates the peak hold mode. To initiate another peak hold, press that key again. The display is now updated with the new peak. The peak hold feature does not operate in the peak-average mode.

To obtain the average-responding, rms-calibrated detector, select AVG.

To initiate the true rms measurement, select RMS (Blue Key, AVG). The true rms detector is selected automatically for the external audio level measurement (Special Function 30), audio distortion measurement, and SINAD measurement (Special Function 29).

HP-IB PROGRAM CODES

Function	Program Code ↔ HP-IB ↔
PEAK+	D1
PEAK-	D2
PEAK HOLD	D3
AVG	D4
RMS	D8
PEAK \pm /2	D9

COMMENTS

Input/Output Status.

The signal at MODULATION OUTPUT/AUDIO INPUT, AM OUTPUT, or FM OUTPUT is not affected by the DETECTOR keys.

True RMS Detector.

Only the true rms detector can be used for external audio level (Special Function 30) and for audio distortion measurement, and SINAD (Special Function 29.)

HP-IB Automatic Selection of Pre-Display.

When the true rms detector is selected, the pre-display mode for FM de-emphasis is automatically enabled. This is true whether FM has been selected or not. (Selection of the FM de-emphasis time constant, however, remains unaffected.) The pre-display mode remains enabled until deliberately disabled. This idiosyncrasy is important to remember when programming the instrument via HP-IB.

Peak Detector's Response Time.

A slower response time for the audio peak detectors can be selected with Special Function 5.1. (Refer to *Audio Detector Response* on page 3-205.)

Peak Hold Mode.

When the peak hold mode is selected, the limited rise time of the peak detector circuitry can cause a slight measurement error for narrow, one-time modulation transients. To prevent this error, repeat the peak-generating process several times while leaving the peak hold mode active.

If PEAK HOLD is selected while the average or true rms detector mode is active, the detector will switch to the peak detector mode previously selected. If PEAK HOLD is selected while the peak-average (PEAK \pm /2) mode is active, the detector reverts to PEAK+ with PEAK HOLD.

HP-IB

In remote operation, new peak-hold cycles can only be initiated by code D3. Thus, if the instrument is in HP-IB Hold mode (code T1), issue code D3 to initiate a peak-hold cycle. Although the display cannot be updated when in HP-IB Hold, the peak is captured, stored and updated. Upon leaving HP-IB hold via the triggering codes (T2 or T3), the data output represents the greatest peak captured since the peak-hold cycle was initiated.

Audio Detector Response

FUNCTIONS

Special Function 5 (Audio Detector Response)

DESCRIPTION

When making modulation measurements, both the audio peak detector response (for peak measurements including SINAD)¹ and the digital averaging response (for rms measurements) are usually fast. A slower response time (narrower detection bandwidth) can be enabled using Special Function 5.1.

The slow response time improves measurement readability on unstable or noisy signals whenever display jitter is excessive.

PROCEDURE

The Measuring Receiver is normally set for fast response. To change from fast to slow or vice versa, enter the corresponding Special Function code, then select SPCL.

Audio Detector Response	Special Function Code	Program Code ↔ HP-IB ↔
Fast	5.0 SPCL	5.0SP
Slow	5.1 SPCL	5.1SP

COMMENTS

Default Condition

When the instrument is first turned on or when Automatic Operation or Instrument Preset is selected, the response time returns to fast.

¹ The slow response time for SINAD is not available with firmware date codes 234.1985 and below. (To display the firmware date code, select 42.0 SPCL.) To order a ROM set that contains this special function, contact the nearest HP sales office.

Audio Filters

FUNCTIONS

HP FILTER, LP FILTER

DESCRIPTION

High-pass and low-pass filters can be inserted in the path of the demodulated signal.

The filters are used for such tasks as rejecting interfering audio signals such as line hum and sub-carriers. They also provide pre-defined bandwidths for residual noise measurements.

PROCEDURE

Insert the desired demodulated signal filter by selecting the appropriate keys. Only one high-pass and one low-pass filter can be inserted at once.

To remove a filter, select the key again.

To select a different filter, press the key corresponding to the desired filter.

HP-IB codes for the various filter keys (listed in the following table) only insert the filters. To remove a high-pass or low-pass filter via HP-IB, use code H0 or L0 (respectively), or select another filter.

HP-IB PROGRAM CODES

HP FILTER	Program Code ↔ HP-IB ↔	LP FILTER	Program Code ↔ HP-IB ↔
ALL OFF	H0	ALL OFF	L0
50 Hz	H1	3 kHz	L1
300 Hz	H2	15 kHz	L2
		>20 kHz	L3

BLOCK DIAGRAM

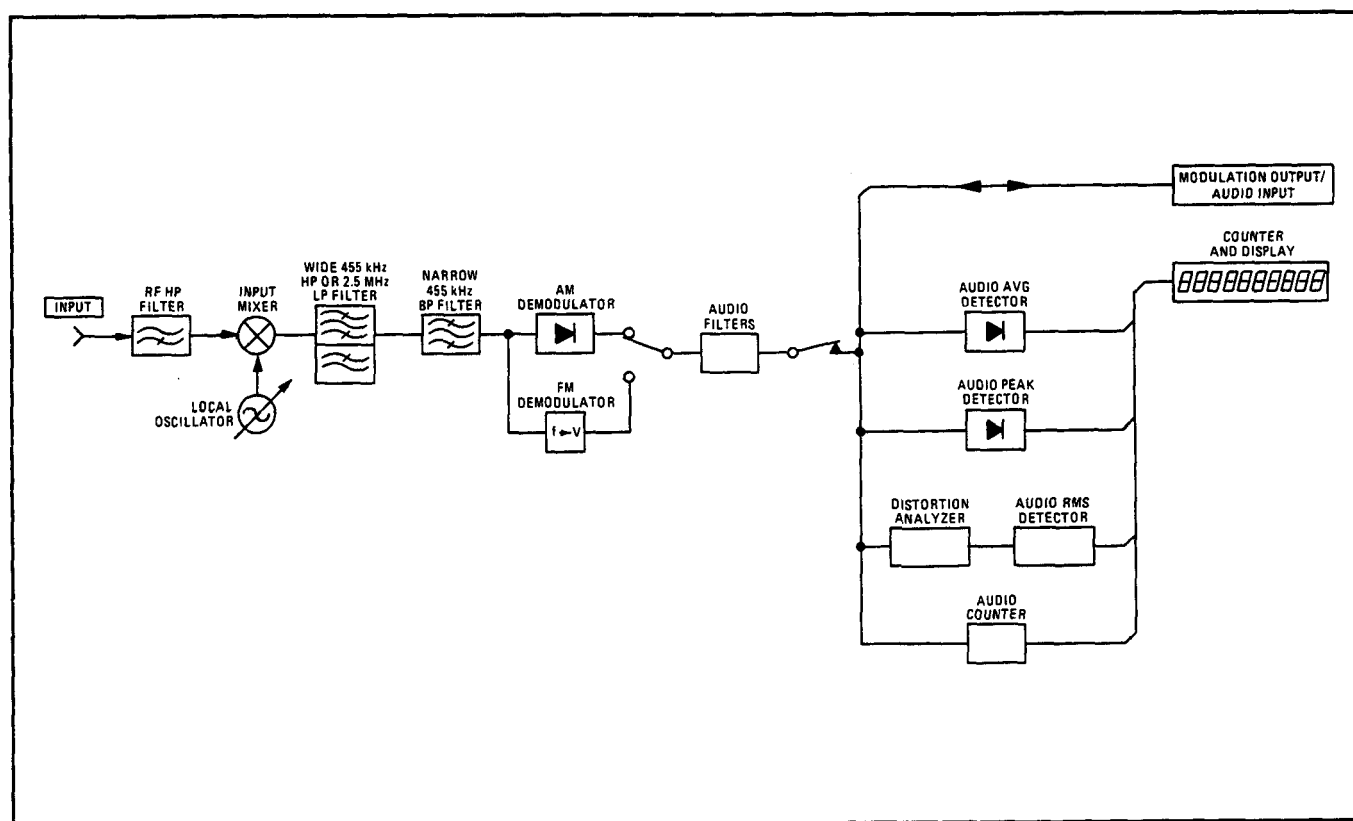

Audio Filters Block Diagram

COMMENTS

Filter Selection Affects Modulation Output.

The selected filters are always in the path of the demodulated signal independent of the selection of a modulation measurement. Thus, unless turned off, the output of **MODULATION OUTPUT/AUDIO INPUT** is filtered. In addition, the selected filters remain in effect when switching between modulation measurements.

Automatic Filter Selection.

Under certain conditions, filters are inserted automatically. When the 455 kHz IF is used, or when the RF input is less than 2.5 MHz, the 15 kHz low-pass filter is inserted unless another low-pass filter has been selected. (The ALL OFF >200 kHz low-pass filtering cannot be selected.) The 15 kHz low-pass filter selected when operating with the 455 kHz IF is automatically turned off when the 1.5 MHz IF is selected.

Bandwidth Limitations.

With no filters selected, the post-demodulation bandwidth is from less than 20 Hz to greater than 200 kHz. (These frequencies refer to the limits over which measurement accuracy is specified, not the 3 dB bandwidth.) However, the IF circuits and demodulators impose more severe bandwidth

limits. Refer to each specific measurement in these Detailed Operating Instructions for bandwidth limitations.

Filter Characteristics.

The individual filter characteristics are given below. The 3 dB bandwidth is specified in the filter's designation and is typically accurate to $\pm 3\%$.

High-Pass Filters:

50 Hz High Pass: Two-pole Butterworth, 1% flat to <200 Hz

300 Hz High Pass: Two-pole Butterworth, 1% flat to <1 kHz

Low-Pass Filters:

3 kHz Low Pass: Five-pole Butterworth, 1% flat to >1 kHz

15 kHz Low Pass: Five-pole Chebyshev, 1% flat to >10 kHz

>20 kHz Low Pass: Nine-pole Bessel, 1% flat to >10 kHz. (When used with square wave modulation, this filter typically overshoots <1%. This filter's 3 dB point is typically 110 kHz.)

Filter Selection Does Not Affect Some Measurements.

External Audio level, distortion, and SINAD measurements are unaffected by the audio filters.

Recommended Filter Selection.

Because of the high sensitivity of the ΦM measurement to low-frequency audio (microphonics, hum, etc.), use of the 50 Hz or 300 Hz low-pass filter is recommended. (Neither is switched in automatically.)

Audio Range

FUNCTIONS

Special Function 2 (Audio Range)

DESCRIPTION

The Measuring Receiver is usually set to automatically select the audio range appropriate for the desired measurement. To set the audio range manually, use Special Function 2.

PROCEDURE

To set the audio range or to re-enter the automatic selection mode, select the corresponding Special Function code.

Modulation Range Peak \pm (%)	Detector Selected	Special Function Code	Program Code ↔ HP-IB ↔	Display Resolution (%)	MODULATION OUTPUT Sensitivity (Vac/% AM)
Automatic Selection		2.0 SPCL	2.0SP	Automatic Selection	
≤ 4	RMS	2.4 SPCL	2.4SP	0.001	0.1
≤ 40	Pk, Avg	2.4 SPCL	2.4SP	0.01	0.1
≤ 40	Pk, Avg, RMS	2.1 SPCL	2.1SP	0.01	0.1
≤ 100	Pk, Avg, RMS	2.2 SPCL or 2.3 SPCL	2.2SP or 2.3SP	0.1	0.01

Audio Range Available for FM

Modulation Range (Peak \pm kHz dev.)	Detector Selected	Special Function Code	Program Code ↔ HP-IB ↔	Display Resolution (Hz)	MODULATION OUTPUT Sensitivity (Vac/% Hz)
Automatic Selection		2.0 SPCL	2.0SP	Automatic Selection	
≤ 0.04	RMS	2.4 SPCL ¹	2.4SP	0.01	100
≤ 0.4	RMS Pk, Avg Pk, Avg, RMS	2.4 SPCL 2.4 SPCL ¹ 2.1 SPCL ¹	2.4SP 2.4SP 2.1SP	0.1	10
≤ 4	Pk, Avg Pk, Avg, RMS Pk, Avg, RMS	2.4 SPCL 2.1 SPCL 2.2 SPCL ¹	2.4SP 2.1SP 2.2SP	1	1
≤ 40	Pk, Avg, RMS	2.2 SPCL 2.3 SPCL ¹	2.2SP 2.3SP	10	0.1
≤ 400	Pk, Avg, RMS	2.3 SPCL	2.3SP	100	0.01

¹ With 750 μ s de-emphasis, pre-display only.

Audio Range Available for Φ M

Modulation Range (Peak \pm rad. dev.)	Detector Selected	Special Function Code	Program Code ↔ HP-IB ↔	Display Resolution (radians)	MODULATION OUTPUT Sensitivity (mVac/radian)
Automatic Selection		2.0 SPCL	2.0SP	Automatic Selection	
≤ 0.4	RMS	2.4 SPCL	2.4SP	0.0001	10
≤ 4	Pk, Avg	2.4 SPCL	2.4SP	0.001	1
≤ 4	Pk, Avg, RMS	2.1 SPCL	2.1SP	0.001	1
≤ 40	Pk, Avg, RMS	2.2 SPCL	2.2SP	0.01	0.1
≤ 400	Pk, Avg, RMS	2.3 SPCL	2.3SP	0.1	0.01

COMMENTS

Audio Range Effect on Distortion Measurements

The selected Audio Range has no effect on audio distortion or SINAD measurements.

When the audio range selected is too high for the level of the audio signal, the signal-to-noise ratio will be low (no error is generated). (The output of MODULATION OUTPUT/AUDIO INPUT tracks the displayed values.) When the audio range is too low for the audio signal level, Error 04 is generated. (The output of the MODULATION OUTPUT/AUDIO INPUT will probably be clipped.) Depending on the audio filtering and detector in use, Error 04 may not be generated at exactly the nominal values listed in the tables above.

Disabling Error 04 Inhibits Audio Autoranging

When Error 04 is disabled (refer to *Error Message Disable Control* on page 3-267), the Measuring Receiver automatically ranges to a less sensitive range when the signal level requires, but it does not range back when the audio level is reduced. This feature is used most often when modulation varies widely with time (such as off-the-air demodulation of a broadcast signal).

Modulation Output/Audio Input

FUNCTIONS

AUDIO INPUT

CAUTION

Do not apply greater than 10 Vdc or greater than +30 dBm (1 watt) into MODULATION OUTPUT/AUDIO INPUT or damage to the instrument may result.

NOTE

For optimum signal flatness, cables attached to MODULATION OUTPUT/AUDIO INPUT (when used as an output) should be terminated in 600 Ω .

DESCRIPTION

Modulation Output.

MODULATION OUTPUT/AUDIO INPUT provides a calibrated output for signals demodulated by the Measuring Receiver. The output signal available at the connector usually corresponds to the current modulation measurement. (The output is dc coupled and has a 600 Ω output impedance into a BNC female connector.)

Audio Input.

The input at MODULATION OUTPUT/AUDIO INPUT also provides external access to the audio measurement circuits. The input impedance at the connector is 100 k Ω .

Effects on Modulation Output/Audio Input During Measurements.

Measurements have a direct effect on MODULATION OUTPUT/AUDIO INPUT. The following table lists the functioning of the MODULATION OUTPUT/AUDIO INPUT for each measurement. (Measurements not listed have no effect.)

Measurement	Measuring Receiver's Response
AM	Selects the demodulated AM signal (unless AUDIO INPUT is selected).
AUDIO DISTN	Measures signal available at MODULATION OUTPUT/AUDIO INPUT (depends on AUDIO INPUT key selection).
AUDIO FREQ	Measures signal available at MODULATION OUTPUT/AUDIO INPUT (depends on AUDIO INPUT key selection).
AUTOMATIC OPERATION	Selects the last-selected modulation measurement.
FM	Selects the demodulated FM signal (unless AUDIO INPUT is selected).
FREQ	Selects the last-selected modulation measurement.
FREQ ERROR	Selects the last-selected modulation measurement.
INSTR PRESET	Refer to Instrument Preset
ϕ M	Selects the demodulated FM signal (unless AUDIO INPUT is selected).
RF POWER	Blanks output; turns off all Modulation Output, Audio Input keylights.
TUNED RF LEVEL	Blanks output; turns off all Modulation Output, Audio Input keylights.
29.0 SPCL (SINAD)	Selects the last-selected modulation measurement.
30.0 SPCL (Ext. Audio RMS Level)	Selects AUDIO INPUT.
33.0 SPCL (LO Frequency)	Selects the last-selected modulation measurement.
34.0 SPCL (IF Frequency)	Selects the last-selected modulation measurement.
35.0 SPCL (RF Level)	Blanks output; turns off all Modulation Output, Audio Input keylights.
36.0 SPCL (Peak Tuned RF Level)	Blanks output; turns off all Modulation Output, Audio Input keylights.
HP and LP Filters, and FM De-emphasis affect the output, but not the input of MODULATION OUTPUT/AUDIO INPUT. (See the Modulation Output/Audio Input Block Diagram in this instruction.)	

Display Resolution vs. Modulation Output Sensitivity

In Automatic Operation, when the Modulation Output/Audio Input feature is used, the output autoranges. Autoranging usually occurs between 3.5 and 4 Vpk, open circuit. Many variables, however, affect the autorange limits and hence the displayed measurement resolution. The variables include: type of modulation, audio detector, audio filtering, and FM de-emphasis. Special Function 2 permits manual setting of the audio range.

The following table examines this relationship. (Refer to *Audio Range* on page 3-211 for more information on modulation ranges.)

AM		FM		ϕM	
Display Resolution (%)	Modulation Output Sensitivity (Vac/%)	Display Resolution (Hz)	Modulation Output Sensitivity (mVac/Hz)	Display Resolution (radians)	Modulation Output Sensitivity (mVac/radian)
0.001	0.1	0.01*	100	0.0001	10
		0.1	10	0.001	1
0.01	0.1	1	1	0.01	0.1
		10	0.1	0.1	0.01
0.1	0.01	100	0.01		

*Available only with 750 μs de-emphasis, pre-display.

BLOCK DIAGRAM

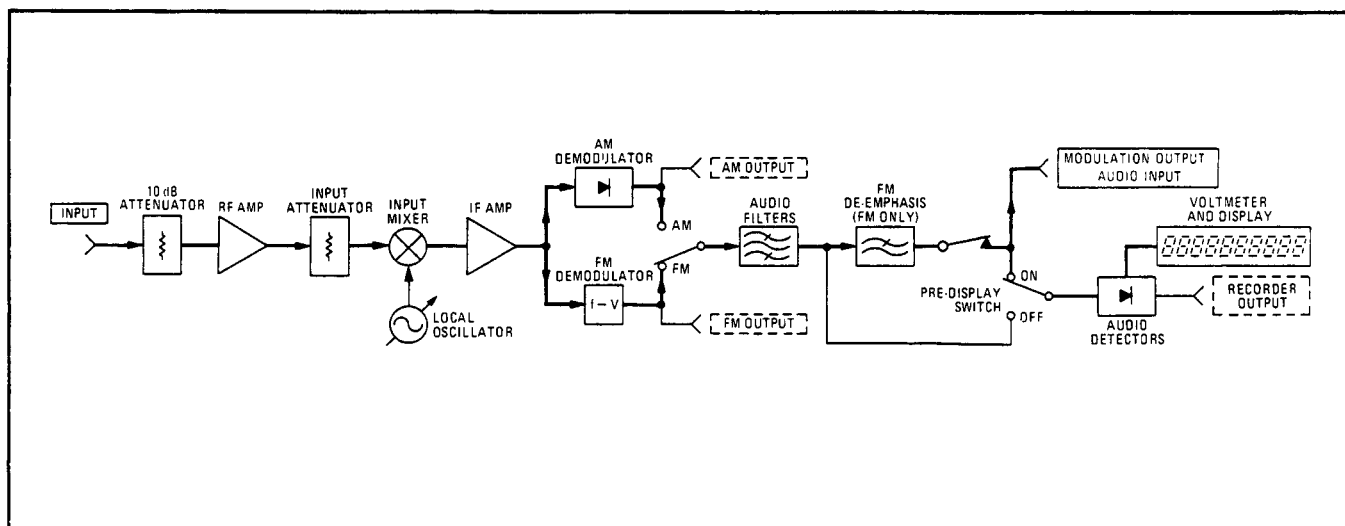

Modulation Output/Audio Input Block Diagram

COMMENTS

Functions That Override Audio Input.

The Audio Input function is overridden by all measurements except audio frequency, distortion, SINAD, and external level.

Errors Disable Output Signal.

Errors 01 through 03, 05, 10, and HP-IB Error 96 (corresponds to a display of two dashes) turn off the signal at MODULATION OUTPUT/AUDIO INPUT.

Default Condition.

When the Measuring Receiver is first powered up, the demodulated output signal at MODULATION OUTPUT/AUDIO INPUT is FM. The sensitivity is 0.01 mV/Hz (the least-sensitive range) and will not autorange to more sensitive ranges. This is because at power up, FREQ is selected. Thus Error 04 (audio circuits overdriven) is automatically disabled. When Error 04 is disabled, only autoranging to less-sensitive audio ranges is allowed.

Safeguarding Output Signal.

When Errors 01 through 04 are always enabled via Special Function 8.8, the output signal at MODULATION OUTPUT/AUDIO INPUT is entirely safeguarded. Under this condition the instrument operates as a calibrated receiver and an error is displayed whenever the signal at MODULATION OUTPUT/AUDIO INPUT is uncalibrated. (Refer to *Error Message Disable Control* on page 3-267.)

Filters Affect Output Signal.

The audio high-pass and low-pass filters and FM de-emphasis affect the output but not the input of the MODULATION OUTPUT/AUDIO INPUT.

Residual Noise Effects

DESCRIPTION

To make the most accurate peak-modulation measurements, it is necessary to measure and correct the effects of residual noise, that is, noise not on the baseband signal, but modulating the RF carrier. The following procedure describes the measurement technique.

PROCEDURE

The following procedure enables the user to correct for the effects of residual noise on peak-modulation measurements.

NOTE

This procedure applies to sinewave modulation only.

1. Set up and make a normal peak-modulation measurement. The displayed measurement result will include the signal plus its noise, $(S + N)_{pk}$.
2. Press the Range Hold key to prevent autoranging. If filtering and/or de-emphasis was used in step 1, make all the following measurements with the same settings.
3. Remove the modulation from the signal and measure the remaining peak-residual noise, N_{pk} , on the carrier.
4. Select AVG. Measure the average residual noise, N_{av} .
5. Compute

$$\frac{(S + N)_{pk}}{N_{pk}} \text{ and } \frac{N_{pk}}{N_{av}}$$

6. Use the following nomograph to determine the percent, $N\%$, of the peak-residual noise level, N_{pk} , to be subtracted from the original, peak-signal-plus-noise measurement, $(S + N)_{pk}$.
7. Compute the corrected, peak modulation

$$S_{pk} = (S + N)_{pk} - N_{pk}(N\%)$$

where $N\%$ is expressed as a ratio (rather than in %).

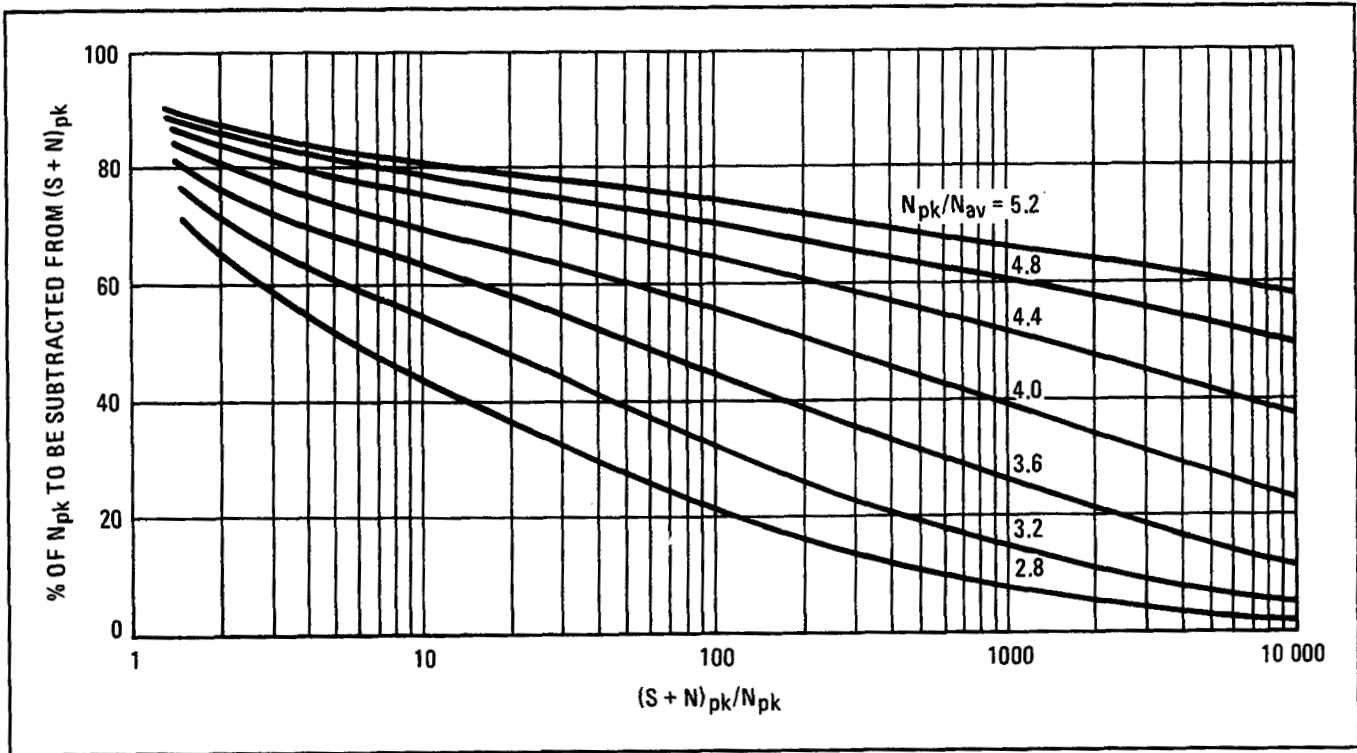

Nomograph for Calculating Percentage of N_{pk} to be Subtracted from $(S + N)_{pk}$ to obtain S_{pk} (Sinewave Modulation Only)

EXAMPLE

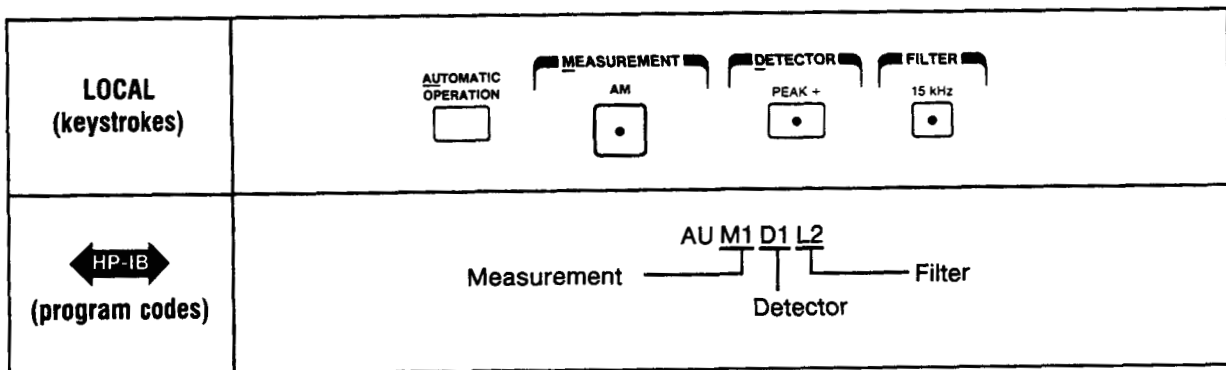

An RF signal is applied to the Measuring Receiver. The modulation rate is 1 kHz and the peak modulation is to be measured in a 15 kHz post-detection bandwidth. To measure the peak AM depth and correct for the effects of residual noise on the modulation:

1. Measure the peak modulation depth, $(S + N)_{pk}$:





For the purposes of subsequent calculations, assume the displayed AM is 30.80%.

2. Disable auto-ranging by pressing the RANGE HOLD key:

LOCAL (keystrokes)	
 (program codes)	G1 Range Hold

3. On the RF signal source, switch the AM off. Measure the residual AM, N_{pk} , on the CW signal. For the purposes of subsequent calculations, assume 0.07% is read on the Measuring Receiver's display.

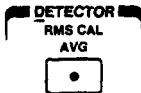
4. Measure the average residual modulation:

LOCAL (keystrokes)	
 (program codes)	D4 Detector

For the purposes of subsequent calculations, assume the displayed average residual AM is 0.02%.

5. Compute:

$$\frac{N_{pk}}{N_{av}} = \frac{0.07\%}{0.02\%} = 3.5\%$$

6. Compute:

$$\frac{(S + N)_{pk}}{N_{pk}} = \frac{30.80\%}{0.07\%} = 440$$

7. Use the nomograph to find N%. (For the purposes of these calculations, assume N% is 26%.)
 Compute:

$$S_{pk} = (S + N)_{pk} - (N_{pk})(N\%) = 30.80\% - (0.07\%)(0.26) = 30.78\%$$

NOTE

This correction factor of <0.1% of the peak reading is typical of a modulation measurement of a quality modulation source measured with the 15 kHz low-pass filter.

THEORY

Residual noise is the short-term amplitude or phase (and thus frequency) instability inherent in any CW signal source. In a measurement system composed of a signal source and the Measuring Receiver, residual noise is contributed by both instruments. When modulation is measured with the Measuring Receiver, both the intended and residual combined are measured. To precisely determine the modulation index due to the baseband signal alone, the effects of residual noise must be factored out of the measurement results.

Two noise components are commonly encountered in modulation measurements: periodic (often line-related) and gaussian (random). Periodic noise and the baseband signal behave identically. The Measuring Receiver measures the arithmetic sum of the peak or average levels of the two signals (according to the detector selected). To determine the modulation index due to the baseband signal alone, switch the modulation off, measure the peak-residual noise on the same range as before, and subtract the result from the original displayed modulation. The effects of random noise on the measurement system are not as straight forward. True random noise, when viewed in the frequency domain, is a continuous spectrum of frequencies at various amplitudes. The frequency of the noise spectrum is limited only by the bandwidths of the observing and/or generating devices. In the time domain, noise of this kind appears as random amplitude spikes (or fuzz) riding on top of the recovered baseband signal. The amplitude of these spikes is limited by the slow rate of the measuring and/or generating devices. Peak detecting these spikes exaggerates the amount of energy present in the noise spectrum so noise measurements are typically made with average-responding detectors and with limited bandwidths.

The measurement problem arises because modulation index is typically expressed as a peak level. To account for residual noise in these peak measurements, the actual effects of the noise on the Measuring Receiver's peak detector must be determined.

A simplified diagram of the Measuring Receiver's peak detector is shown in the following figure. Whenever the signal-plus-noise voltage into the comparator exceeds the voltage stored on the output capacitor, C, the comparator closes switch S1. The capacitor is then charged via the path from +V through resistor R. When the voltage across the capacitor exceeds the voltage of the incoming signal, the comparator opens the switch again. This process continues until the voltage on the capacitor is transferred to the voltmeter through the sample-and-hold switch, S2. C is then discharged by S3. When very narrow noise spikes are imposed on the comparator's input, the charging circuit's RC time constant will not allow the capacitor to fully charge before the noise peak has passed.

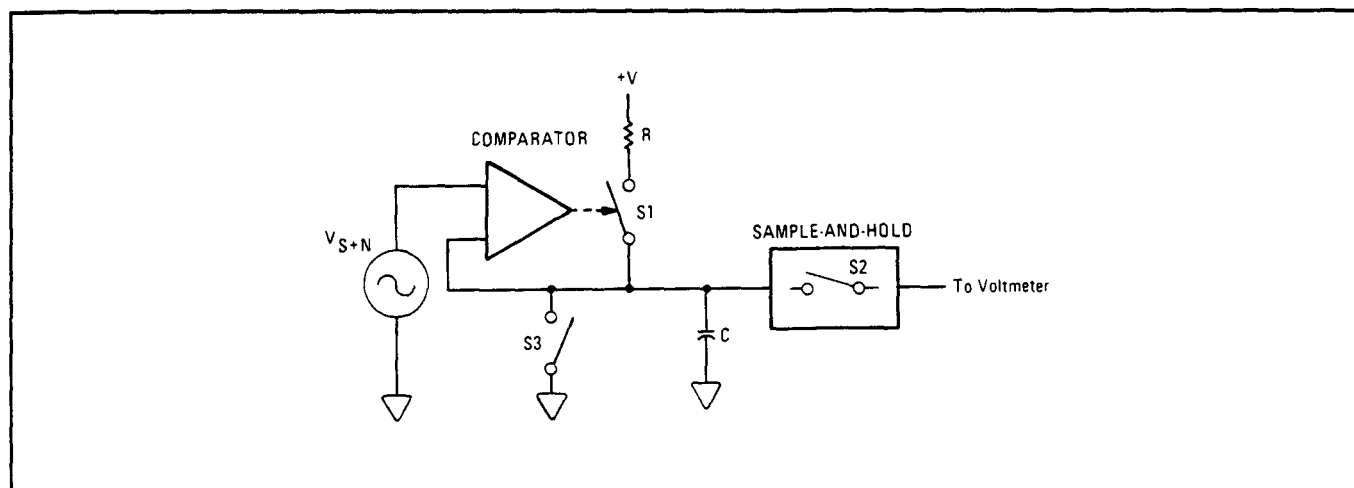

Simplified Diagram of the Measuring Receiver's Peak Detector

When noise alone is imposed on the detector, it is very probable that, as C begins to charge, a noise spike will exceed the voltage across the peak detector capacitor. However, as the voltage across the capacitor more nearly approaches the peak-noise level, this probability decreases. Thus the peak detector, over a significantly long time, can faithfully measure fairly high peak-noise levels.

When noise is riding on a sinewave, only the signal-plus-noise peaks exceeding the sinusoid's peak level can add charge to the peak detector capacitor. Statistically, there is less chance that the composite input signal will exceed the voltage across the capacitor (already charged to the peak of the sinewave) when measuring a sinewave than when measuring only noise. Thus, the contribution of noise on the measured peak-modulation level decreases as the signal-to-noise ratio increases.² To simply measure the peak-residual noise present when the modulation is removed and subtract the result directly from the peak reading of the combined input, over-compensates the effects of the noise.

The effects of residual noise on the peak detector depend on the signal-to-noise ratio, the statistics of the noise spikes, and the response time of the specific peak detector. These effects are quantified by taking the ratio of the peak noise reading to the average noise reading. The average noise level is a truer measure of the actual amount of noise energy present, while the peak reading characterizes the peak detector and the statistics of the noise spikes.

COMMENTS

Noise Must Be Gaussian.

The primary restriction placed on this method of accounting for residual noise is that the noise must be gaussian (that is, statistically random). Periodic noise (for example, line-related noise) has repeating peaks and thus does not fall within the statistical model used to derive the nomograph given in the procedure.

A noise-peak-to-noise-average ratio (N_{pk}/N_{av}) greater than 4.4 is a strong indication of a periodic component in the residual noise.

Use Range Hold During Measurement.

Both the modulation and the noise measurements used with the nomograph should be made on the same modulation range and with the same peak-detector time-constant. Use the Range Hold key while the instrument is measuring the modulated carrier, then measure the residual noise.

Select the Highest of Successive Readings.

When characterizing the effects of residual noise on peak Φ M measurements using the 3 kHz low-pass filter, readings may jump considerably. Use the highest of 10 successive readings for all peak measurements in the computations. (Simply select PEAK HOLD and note the reading after 2 seconds.)

No Residual Noise in Calibration.

The residual noise contributions of the AM and FM calibrators and the Measuring Receiver are accounted for in the calibration procedures. It is not necessary to factor residual noise corrections into the calibration procedures described in this manual. (Refer to AM Calibration and FM Calibration.)

Considerations When Using the RMS Detector

During FM measurements if the RMS detector is selected (Blue Key, AVG), FM de-emphasis pre-display is automatically selected. Pre-display must turn on at this time due to circuit configuration of the Measuring Receiver. When pre-display is selected this way, it will not turn off automatically when another detector is selected. Turn off pre-display (after selecting another detector) by pressing the PRE DISPLAY key (HP-IB code: P0). Measurements could be affected by this pre-display selection.

² Rice, S.O., "Statistical Properties of a Sine Wave Plus Random Noise", Bell System Technical Journal, 27, No.1. (January, 1948), pp. 109-157.

Audio Measurements Contents

AUDIO MEASUREMENTS

Audio Frequency	3-227
• How to count the demodulated audio frequency.	
• How to count an external audio frequency.	
Audio Distortion and Level	3-229
• How to measure audio distortion (only at 400 Hz or 1 kHz) on either an internally demodulated or an external audio input.	
• How to measure the level of external audio input.	
SINAD	3-233
• How to measure SINAD (only at 400 Hz or 1 kHz) on either an internally demodulated or an external audio input.	

Audio Frequency

FUNCTIONS

AUDIO FREQ, AUDIO INPUT

DESCRIPTION

Audio Frequency counting can be performed on either demodulated internal signals or external audio signals as determined by the AUDIO INPUT key.

PROCEDURE

To count the frequency of the audio signal demodulated from the RF signal at the INPUT connector, select AUDIO FREQ (Shift, AM).

To count the frequency of an external audio signal at the MODULATION OUTPUT/AUDIO INPUT connector, follow the above procedure, and then select AUDIO INPUT. The measurement range is 20 Hz to 250 kHz. The input signal should not exceed 4 Vrms. The input impedance is approximately 100 k Ω .

HP-IB PROGRAM CODES

AUDIO FREQ = S1
AUDIO INPUT = A1

MEASUREMENT TECHNIQUE

The audio frequency is measured by a reciprocal-type counter. The input can be either the demodulated RF at the INPUT or an external audio input at the MODULATION OUTPUT/AUDIO INPUT. The Measuring Receiver gates its internal 10 MHz time base reference with the audio input signal for at least 100 ms. The frequency is then determined by the following equation:

$$\text{audio frequency} = \frac{(\text{number of cycles of audio signal}) \times 10 \text{ MHz}}{\text{number of time base reference pulses}}$$

The combination of minimum count time of 100 ms and the 10 MHz time base reference assures six-digit resolution.

The function of MODULATION OUTPUT/AUDIO INPUT connector is controlled by the AUDIO INPUT key. The connector has an input impedance of approximately 100 k Ω .

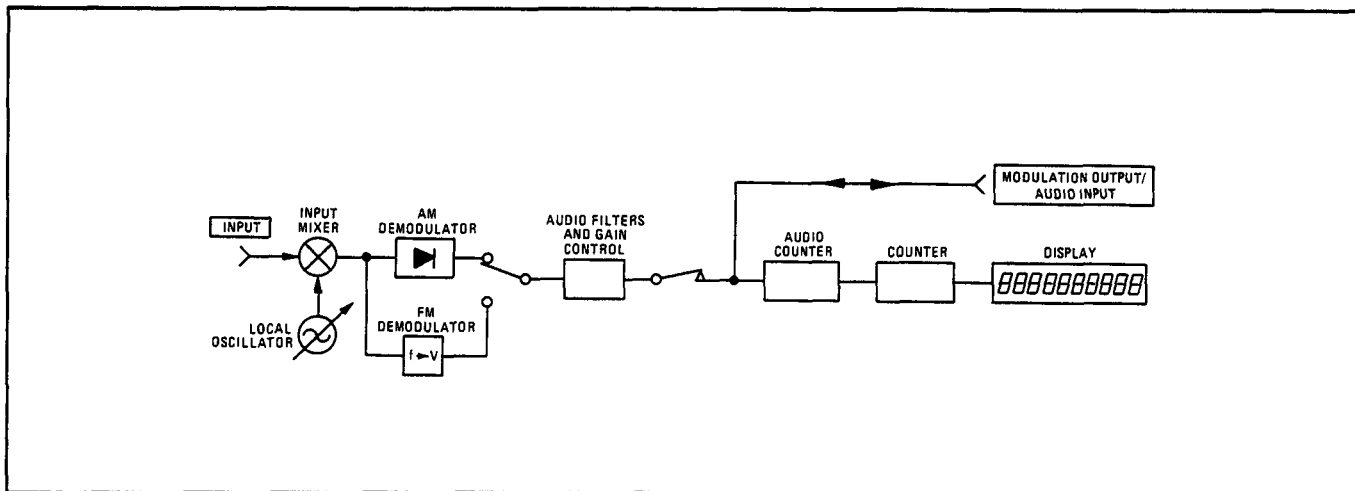

Audio Frequency Block Diagram

COMMENTS

Relative Measurements

If audio frequency is to be displayed relative to a reference, enter the value as a ratio reference using the Ratio function. (Refer to *Ratio* on page 3-145.)

Finer Resolution for Frequencies from 100 to 250 kHz ¹

Special Function 32.1 enables a resolution of 0.1 Hz for frequencies 100 to 250 kHz. For dB measurements, this special function enables a resolution of 0.001 dB instead of the normally displayed resolution of 0.01 dB. The selection of Special Function 32.0 or 32.1 is maintained through instrument power down.

32.0 Audio frequency is displayed with the normal resolution of 1 Hz for frequencies from 100 to 250 kHz.

32.1 Audio frequency is displayed with a resolution of 0.1 Hz for frequencies from 100 to 250 kHz.

32.2 Displays 0 if the normal measurement resolution is enabled (32.0 SPCL) and displays 1 if a finer resolution is enabled (32.1 SPCL).

¹ This special function is not available with firmware date codes 234.1985 and below. (To display the firmware date code, select 42.0 SPCL.) To order a ROM set that contains this special function, contact the nearest HP sales office.

Audio Distortion and Level

FUNCTIONS

AUDIO DISTN, 1 kHz DISTN, 400 Hz DISTN, RMS, AUDIO INPUT, Special Function 30 (External Audio RMS Level)

DESCRIPTION

Measure distortion on either internally demodulated audio signals or externally input signals with fundamental frequencies of 1 kHz or 400 Hz. (The fundamental frequency must be within $\pm 5\%$ of the nominal 1 kHz or 400 Hz for accurate measurements.) Once selected, the measurement frequency remains unchanged and is automatically activated each time the audio distortion (or SINAD) measurement is selected.

Special Function 30.0 enables the instrument to measure the true rms level of an external signal applied to the MODULATION OUTPUT/AUDIO INPUT connector. (The connector is automatically switched to function as an input upon selection of Special Function 30.0. The true rms level of the internal demodulated audio cannot be measured.) Connector input impedance is nominally 100 k Ω . The maximum measurable input level is 4 Vrms.

PROCEDURE

To measure distortion on the demodulated audio signal, select AUDIO DISTN (Shift, FM).

To measure distortion on an external audio signal applied to the MODULATION OUTPUT/AUDIO INPUT, select AUDIO DISTN (Shift, FM) and AUDIO INPUT. (Only the true rms detector can be used for these measurements.)

To change the measurement bandwidth of the internally demodulated audio signal, Select the desired filter keys. (Refer to *Audio Filters* on page 3-207.)

If measurements are to be made on a 1 kHz audio signal, select 1 kHz DISTN (Blue Key, PEAK+). If measurements are to be made on a 400 Hz audio signal, select 400 Hz DISTN (Blue Key, PEAK-).

To measure the true rms level of an audio signal applied to the MODULATION OUTPUT/AUDIO INPUT, select 30.0 SPCL.

HP-IB PROGRAM CODES

AUDIO DISTN=S2
 AUDIO INPUT = A1
 MODULATION OUTPUT = A0
 1 kHz DISTN = D5
 400 Hz DISTN = D6
 LIN results = LN
 LOG results = LG
 mV units = MV
 uV units = UV
 VOLTS units = VL
 SPCL = SP

MEASUREMENT TECHNIQUE

To measure audio distortion, the instrument compares the input signal level measurement made with a true rms detector to the same measurement made with the fundamental component removed. Total harmonic distortion is then calculated as the ratio of the signal with its fundamental removed to the unfiltered signal.

The broadband audio signal is first measured with a true rms detector; then the audio signal path is switched through a notch filter set to the fundamental frequency (1 kHz or 400 Hz). The notch filter has approximately 55 dB rejection at the notch frequency with 10% total bandwidth. The distortion is computed as the ratio of the signal from the output of the notch filter to the signal without filtering.

The function of the MODULATION OUTPUT/AUDIO INPUT is controlled by the AUDIO INPUT key. The connector has an impedance of approximately 100 k Ω when used as an input and 600 Ω when used as an output.

The true rms level (from 0V to 4V) of any external audio signal (from 20 Hz to 40 kHz) can be measured using the same rms detector. (In this mode, the MODULATION OUTPUT/AUDIO INPUT connector always functions as an input.)

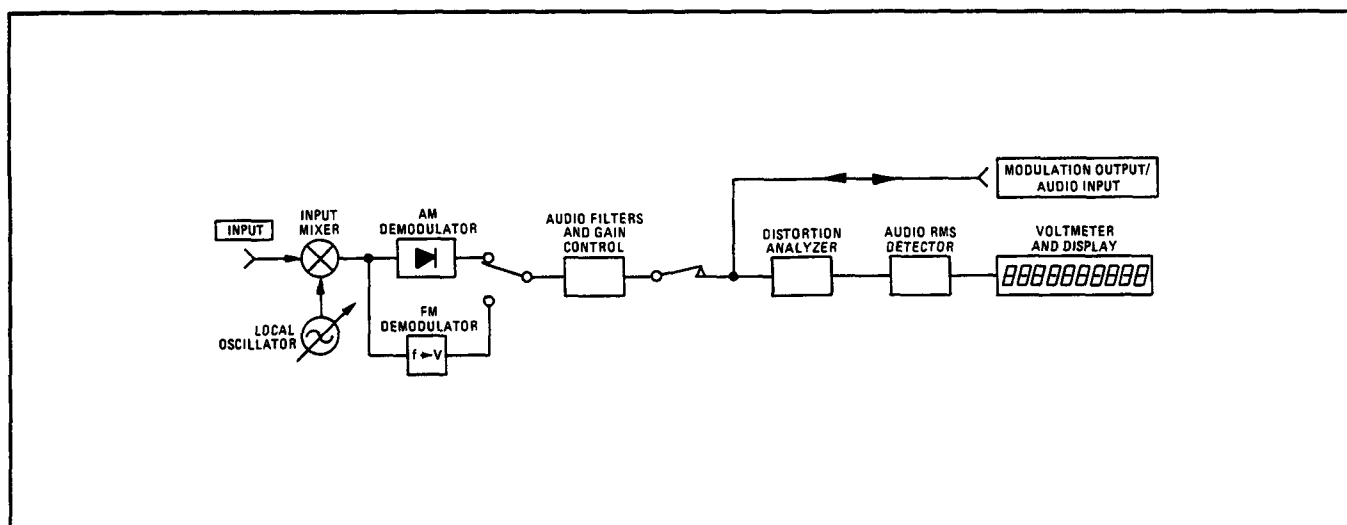

Auto Distortion and Level Block Diagram

COMMENTS

Audio Level Measurement in Watts

Selection of watts as the unit for audio level measurements results in an error.

Automatic Selection of RMS and PRE DISPLAY

Selection of an audio distortion or level measurement automatically selects the true rms audio detector and sets FM de-emphasis to the pre-display mode. (Refer to *FM De-emphasis* on page 3-187.)

The SINAD measurement mode (Special Function 29) is almost identical to the audio distortion measurement mode. SINAD, as measured by the instrument, is the reciprocal of distortion. (Refer to *SINAD* on page 3-233.)

Relative Measurements

If audio distortion or level are to be displayed relative to a reference, enter the value as a ratio reference by selecting **RATIO**. (Refer to *Ratio* on page 3-245.) The measured results can be displayed in either linear units (mV, %, etc.) or logarithmic units (dBV, dB, etc.) using the **LOG/LIN** key. The previously selected units are reinstated whenever an audio measurement is selected.

SINAD

FUNCTIONS

1 kHz DISTN, 400 Hz DISTN, Special Function 29 (SINAD)

DESCRIPTION

Special Function 29.0 enables the Measuring Receiver to make SINAD (Signal to Noise And Distortion) measurements. The SINAD measurement is identical to the audio distortion measurement; but the result is expressed differently. SINAD is often measured as part of receiver sensitivity testing.

SINAD can be measured on audio signals with fundamental frequencies of either 1 kHz or 400 Hz using the 1 kHz DISTN or 400 Hz DISTN keys respectively. The fundamental frequency must be within $\pm 5\%$ of the nominal 1 kHz or 400 Hz for accurate measurements. Once selected, the measurement frequency remains unchanged and is automatically activated each time the SINAD (or audio distortion) measurement is selected.

SINAD can also be measured on an external audio signal applied to the MODULATION OUTPUT/AUDIO INPUT connector using the AUDIO INPUT key. When external audio is not selected, the instrument measures the SINAD on the internal demodulated audio.

PROCEDURE

To measure SINAD on the demodulated audio signal, select 29.0 SPCL.

To measure SINAD on an external audio signal applied to the MODULATION OUTPUT/AUDIO INPUT, select 29.0 SPCL and AUDIO INPUT. (Only the true rms detector can be used for this measurement.)

To change the measurement bandwidth of the internally demodulated audio signal, select the desired filter keys. (Refer to *Audio Filters* on page 3-207.)

If measurements are to be made on a 1 kHz signal, select 1 kHz DISTN (Blue Key, PEAK+). If measurements are to be made on a 400 Hz audio signal, select 400 Hz DISTN (Blue Key, PEAK-).

The measured results can be displayed in either linear units (%) or logarithmic units (dB) using the LOG/LIN key. The previously selected units are reinstated whenever an audio measurement is selected.

HP-IB PROGRAM CODES

AUDIO INPUT = A1
 MODULATION OUTPUT = A0
 1 kHz DISTN = D5
 400 Hz DISTN = D6
 LIN results = LN
 LOG results = LG
 SPCL = SP

MEASUREMENT TECHNIQUE

To measure SINAD, the instrument compares the input signal level measured by a true rms detector to the same measurement with the fundamental component removed. SINAD is then calculated as

the ratio of the unfiltered signal to the signal with its fundamental removed. Refer to the measurement technique discussions in *Audio Distortion and Level* on page 3-229.

COMMENTS

Relative Measurements.

If SINAD is to be displayed relative to a reference, enter the value as a ratio reference using the **RATIO** key. (Refer to *Ratio* on page 3-245.)

SINAD Response Time.

A slower response time can be selected with Special Function 5.1.² The slow response time improves measurement readability on unstable or noisy signals whenever display jitter is excessive.

² The slow response time for SINAD is not available with firmware date codes 234.1985 and below. (To display the firmware date code, select 42.0 SPCL.) To order a ROM set that contains this special function, contact the nearest HP sales office.

Additional Capabilities Contents

FUNCTIONS THAT CAN BE USED WITH MANY MEASUREMENTS

Automatic Operation	3-237
<ul style="list-style-type: none"> • How to cancel special functions or automatically tune the instrument. 	
Instrument Preset	3-239
<ul style="list-style-type: none"> • How to preset the instrument to its default state. • What the default conditions are. 	
Range Hold	3-243
<ul style="list-style-type: none"> • How to freeze current measurement ranges. 	
Ratio and Log/Lin	3-245
<ul style="list-style-type: none"> • How to scale a measurement result to a reference in % or dB. 	
Limit	3-249
<ul style="list-style-type: none"> • How to set limits on measurements being made. • How overlimiting is displayed (front panel and HP-IB). 	
Store/Recall	3-253
<ul style="list-style-type: none"> • How to access the instrument's 8 storage registers. 	

FUNCTIONS THAT INCREASE MEASUREMENT CAPABILITIES

Frequency Offset Control	3-255
<ul style="list-style-type: none"> • How to extend the frequency range of the instrument into the microwave region using an external down-converter. 	
Filters, RF and IF	3-259
<ul style="list-style-type: none"> • How to insert the RF high-pass filter in the RF signal path to eliminate interfering, low-frequency signals. • How to select the frequency and bandwidth of the IF filters. 	
IF Gain	3-263
<ul style="list-style-type: none"> • How to select IF gain to improve measurement sensitivity. 	
RF Input Attenuation and Gain	3-265
<ul style="list-style-type: none"> • How to select RF input attenuation or amplification to eliminate input overload or to improve measurement sensitivity. 	
Error Message Disable Control	3-267
<ul style="list-style-type: none"> • How to disable or enable combinations of Errors 01 through 04 to extend the instrument's usable measurement range. 	

Automatic Operation

FUNCTIONS

AUTOMATIC OPERATION

DESCRIPTION

The Automatic Operation function fulfills two major functions: (1) To configure the Measuring Receiver to automatically tune to the largest detectable RF input signal and to make the selected measurement. (2) To cancel most special functions.

Specifically, Automatic Operation sets special functions with prefixes 1 through 10 to their 0-suffix state, cancels many special functions with prefixes greater than 10, and overrides all service special functions (prefixes 0, 40, or greater). (Refer to *Special Functions* on page 3-271 for details on special functions 1 through 39. Refer to Section 8 of the Service Manual for details on Service Special Functions.) Automatic Operation also cancels some front-panel settings (TRACK MODE, RANGE HOLD, and DISABLE ERROR).

Those features that are not affected by Automatic Operation include HP or LP FILTERs, FM DE-EMPHASIS, MEASUREMENT, CALIBRATION, DETECTOR, DISPLAY, and RATIO. RF level- and modulation-related calibration factors remain intact. Limit settings (Special Function 14) and Frequency Offset Control (Special Function 27) are also not affected.

PROCEDURE

To enter the Automatic Operation mode, select Automatic Operation. The instrument will immediately re-tune to the input signal and make the measurement selected.

HP-IB PROGRAM CODE

AUTOMATIC OPERATION = AU

COMMENTS

Input/Output Status

MODULATION OUTPUT/AUDIO INPUT is blanked temporarily during the automatic tuning process initiated by selecting Automatic Operation.

The Value of the Automatic Operation Capability

Automatic Operation is the easiest way to make measurements in applications where only a single carrier is present at the RF INPUT. The instrument configures itself to meet the needs of most measurement situations, and all error messages signaling inaccurate measurements are enabled.

Range Hold is Opposite to Automatic Operation

The converse of the Automatic Operation mode is the Range Hold function.

Restrictions on Entering Automatic Operation

The instrument cannot enter the Automatic Tuning mode when making any tuned RF level measurements.

Instrument Preset

FUNCTIONS

Includes all Power-Up and Default Conditions and HP-IB Clear

DESCRIPTION

When first turned on (during power-up), the Measuring Receiver passes through a sequence of internal checks before it is ready to make measurements. The results of these checks are indicated internally as a service aid. (Refer to Section 8.) The running of the power-up sequence is indicated to the user by lighting all front-panel indicators (burned-out LEDs are evident at this time). After approximately 10 seconds, this sequence is completed.

When the Instrument Preset key is pressed, the instrument configures itself the same as during power-up, but bypasses the internal checks.

The Measuring Receiver contains a battery back-up to its internal memory, which makes part of the memory non-volatile after the power has been switched off (powered-down)—even if the power cord is unplugged.

Information retained after power-down:

- The 8 instrument states stored in the Store/Recall registers.
- For RF Power:
 - a. One set of zero and calibration (SAVE CAL) data.
 - b. One table of 16 frequency/calibration factor pairs and the reference calibration factor used with RF power sensors.
 - c. One table of 22 frequency/calibration factor pairs and the reference calibration factor used with microwave power sensors in the Frequency Offset mode.
 - d. The state of Special Function 32.0 or 32.1 (dB and frequency resolution).
- For Tuned RF Level:
 - a. Four calibration factors.
 - b. The frequency at which the calibration factors are valid.
 - c. The state of the RF High-Pass Filter, Wide IF Filters, and Narrow IF Filters at the time of calibration (Special Function 3).
 - d. The state of Special Function 1.0 or 1.9 (RF input attenuator and gain).
 - e. The state of Special Function 32.0 or 32.1 (dB and frequency resolution).
- For AM and FM:

An AM calibration factor and an FM calibration factor (both in disabled mode).

Default conditions after power-up or instrument preset:

If no signal is present at the INPUT connector and no HP-IB controller is connected, the measurement conditions and front-panel annunciators are as follows:

Measurement Conditions

Tuning	Automatic Signal Search
Measurement Mode:	Frequency
Modulation Output/Audio Input:	Blanked
Calibration Mode:	Off
HP-IB:	(See "COMMENTS".)
Special Functions:	(See below.)

If a suitable signal is present at the INPUT connector and no HP-IB controller is connected, the measurement conditions, front-panel annunciators, and Special Functions are as follows:

Measurement Conditions

Tuning:	Automatic, Low-Noise
Measurement Mode:	Frequency
IF Frequency:	Automatic Selection
Modulation Output/Audio Input:	Output FM
High-Pass Filter:	All Off
Low-Pass Filter:	All Off (15 kHz if input < 10 MHz)
Calibration Mode:	Off
HP-IB:	(See "COMMENTS".)
Special Functions:	(See below.)

Special Functions

1-10:	suffix is set to 0
11 Previous Ratio:	off
Ratio Reference:	100%
14 Limit:	off
Upper Limit:	1300
Lower Limit:	0.150
Upper/Lower Limit Code:	0.005 (FREQ)
16 AM Calibration Factors:	100% or previous power-down value
17 FM Calibration Factors:	100% or previous power-down value
22 Service Request:	suffix set to 2
Status Byte:	cleared
25 External Attenuation:	0 dB
26 Set Reference:	0 dBm
27 Frequency Offset Control:	0 MHz
37 Calibration Factors, RF Power:	[both calibration factor tables from previous power-down]
Mode:	Automatic Cal Factor Mode
38, 39 Calibration Factors, Tuned RF Level:	4 calibration factors and RF and IF filters from previous power-down

PROCEDURE

To cause the instrument to run through its internal checks and reset the instrument to its default state, turn the instrument off, then on again.

To reset the Measuring Receiver to its default state but bypass the internal power-up checks, select INSTR PRESET (Blue Key, AUTOMATIC OPERATION), or issue a device clear command from an HP-IB controller.

To initiate the internal power-up checks, select 40.0 SPCL.

HP-IB PROGRAM CODES

INSTR PRESET (Device Clear) = IP

SPCL = SP

The instrument can also be preset using the device clear bus command. (Refer to the *Remote* section on page 3-25.)

COMMENTS

Setting the Instrument to a Known State.

The Instrument Preset feature is a very simple means of setting the instrument to a known state when writing test procedures involving the Measuring Receiver.

Losing Instrument States with a New Controller Assembly.

After plugging in a new controller Assembly, some or all of the instrument states stored through power-down may be non-existent. If this information is lost:

- a. The Recall function reverts to the Instrument Preset state.
- b. The RF Power measurement will: (1) display Error 15, (2) light the UNCAL and RECAL annunciators, and (3) use the default zero and calibration factors. (The RF power calibration factors must be re-entered.)
- c. The calibration factors for Tuned RF Level will be displayed as 0.0% (using Special Function 38).
- d. AM and FM calibration factors will be 100% when enabled (using Special Function 16 or 17).

Instrument Preset Clears Pending Require Service Messages.

When the instrument is preset, any pending Require Service Message is cleared. (For more details, refer to Receiving the Clear Message, in Remote Operation.)

CLEAR Key.

The HP-IB Clear message should not be confused with the front-panel CLEAR key or its CL HP-IB code. The HP-IB Clear message presets the instrument. The CLEAR key clears the display and returns the instrument to its previous state.

Alternative to Turning the Instrument Off and then On.

Use special function 40.0 to cause the Measuring Receiver to pass through its internal checks. (Special function 40.0 is not accessible from the HP-IB.)

Range Hold

FUNCTIONS

RANGE HOLD

DESCRIPTION

The Range Hold function freezes the current ranges being used by the Measuring Receiver. This function, the converse of Automatic Operation, disables automatic tuning and sets Special Functions prefixed 1, 2, 3, 7, 9, and 10 to the current range settings. The following functions are not affected by Range Hold: High-pass and Low-pass Filters, FM De-emphasis, Measurement, Detectors, and Display. Special Functions prefixed 1 through 10 that are already manually set are unaffected. The table below summarizes the effect of the Range Hold feature:

Special Function Prefix	Measurement Function	Effect of RANGE HOLD on Functions
1	RF Input Attenuation and Gain	Holds setting
2	Audio Range	Holds setting
3	RF and IF Filters	Holds setting
4	Tuned RF Level Display Averaging	No effect
5	Audio Detector Response	No effect
6	AM ALC Response	No effect
7	RF Frequency Resolution	Holds setting
8	Error Message Disable	No effect
9	IF Gain	Holds setting
10	RF Power Range	Holds setting
	AUTO TUNING	Selects Manual Tuning

PROCEDURE

To hold instrument settings in a specific measurement state, set the Measuring Receiver as desired, then select RANGE HOLD.

To exit the Range Hold mode, select RANGE HOLD a second time or select AUTOMATIC OPERATION.

HP-IB PROGRAM CODE

Automatic Ranging = G0
RANGE HOLD = G1

COMMENTS**Altering Held Functions.**

Once settings are held with the Range Hold function, they can be altered by manually entering the desired setting. For example, the Range Hold function places the instrument in the manual tune mode; select AUTO TUNING (Blue Key, TRACK MODE) to re-enter the automatic tuning mode. Similarly, Special Functions can be used to set other functions or selectively return them to automatic operation.

Ratio and Log/Lin

FUNCTIONS

RATIO, PREVIOUS RATIO, LOG/LIN, Special Function 11 (Previous Ratio)

DESCRIPTION

The Ratio and Previous Ratio functions permit any measurement result to be scaled to a reference. The reference may be either a measurement result or a keyboard entry. Special Function 11.2 displays the current ratio reference.

The LOG/LIN key enables measurement results to be displayed in linear or logarithmic units, both absolute and relative. Examples of absolute units are kHz and mV (linear), or dBm (logarithmic). Examples of relative units are % and dB. For purposes of discussion, basic measurement units, such as % for AM or distortion, dB for SINAD, etc., (though actually relative units), are treated as absolute units. When the instrument displays % and dB as relative units (that is, when the ratio function is used), annunciator REL is added to the display.

All modulation and all frequency measurement results cannot be displayed with absolute, logarithmic units even though they can be displayed in relative, logarithmic units. (The LOG/LIN key is ignored.)

The Ratio function can be used with the following measurements:

AM	SINAD (29.0 SPCL)
FM	Ext Audio RMS Level (30.0 SPCL)
ΦM	LO Frequency (33.0 SPCL)
RF POWER	IF Frequency (34.0 SPCL)
FREQ	RF Level (35.0 SPCL)
AUDIO FREQ	Peak Tuned RF Level (36.0 SPCL)
AUDIO DISTN	
IF LEVEL	
TUNED RF LEVEL	
FREQ ERROR	

The Ratio function is exited when:

- the RATIO key is pressed a second time,
- a new measurement is selected, or
- other measurement units are selected.

PROCEDURE

Select LOG/LIN anytime during a measurement to change the display between linear and logarithmic units, where permitted, for both absolute and relative (Ratio) displays.

To use the Ratio function:

1. Select the desired Measurement mode. Measurements possible with the ratio function are listed in "DESCRIPTION."

2. Set the display to the desired reference value, either
 - adjust the signal parameter being measured for a display equal to the desired reference, or
 - enter the reference on the numeric keys. (If the reference value is to be negative, select minus; that is, the Blue Key, then the decimal key.)
3. Select **RATIO**. The display will show the measurement result relative to the reference.

To use the Previous Ratio function to restore a previously-entered ratio reference:

1. Select the desired Measurement mode.
2. Select **PREVIOUS RATIO** (Blue Key, **RATIO**). The display will show the measurement result relative to the original ratio reference. (The Measuring Receiver uses the previous ratio reference regardless of what Measurement the instrument was in when the ratio reference was entered and regardless of the current Measurement mode.)

To display the ratio (or previous ratio) reference, key in 11.2 SPCL.

EXAMPLES

Assume 35.35 kHz FM deviation is displayed. Enter this value as the ratio reference for subsequent measurements:

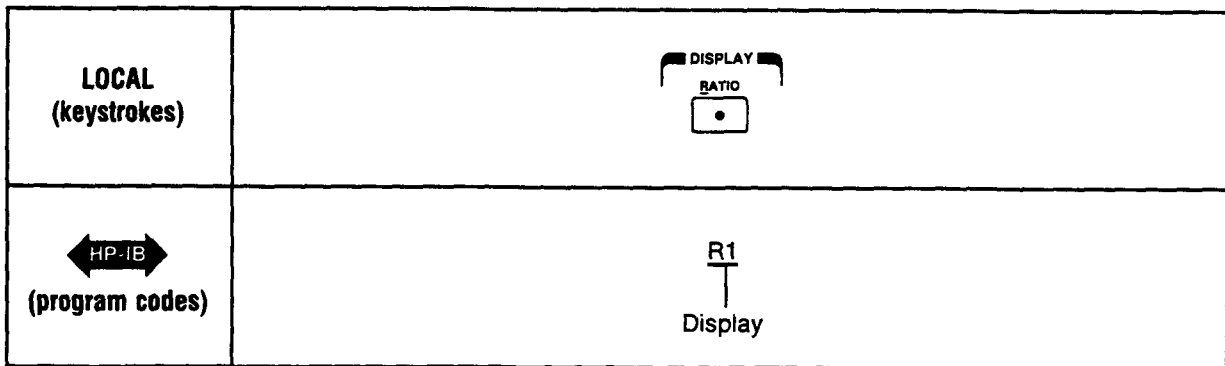

The displayed measurement result is 100% REL if linear units are selected or 0 dB REL if logarithmic units are selected. (The display will normally vary about these nominal values due to noise and the typical one-count uncertainty in the measured result.)

If it is desired to scale FM measurement results relative to 50 kHz, set the Measurement mode to FM:

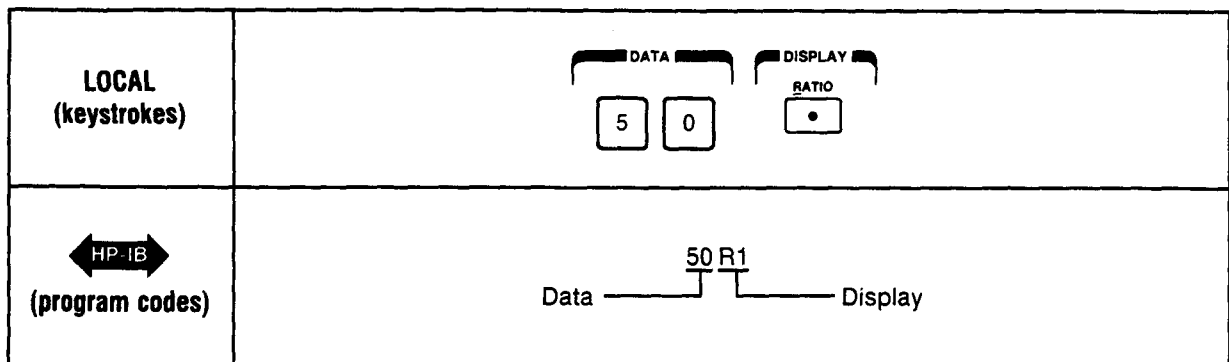

If, as in the previous example, 35.35 kHz FM deviation was measured, the displayed measurement result will be 70.7% REL if linear units are selected or -3.01 dB REL if logarithmic units are selected.

HP-IB PROGRAM CODES

LOG display = LG
 LIN display = LN
 PREVIOUS RATIO = R2
 RATIO off = R0
 RATIO on = R1
 SPCL = SP

MEASUREMENT TECHNIQUE

In the Ratio mode, measurements are made in the same way as when not in the Ratio mode; however, before the result is displayed, the internal controller converts it to ratio. The following equations are used for computing ratio:

$(M/R) (100\%) = \% \text{ ratio for all measurements,}$

$(20) \log (M/R) = \text{dB ratio for the following measurements:}^1 \text{ AM FM, } \Phi\text{M, AUDIO DISTN, IF LEVEL, SINAD (29.0 SPCL), Ext Audio RMS Level, and } (10) \log (M/R) = \text{dB ratio for the following measurements:}^2 \text{ FREQ, AUDIO FREQ, FREQ ERROR, LO Frequency (33.0 SPCL), IF Frequency (34.0 SPCL),}$

where M is the (undisplayed) measurement result and R is the ratio reference.

COMMENTS

Input/Output Status.

The output signal at MODULATION OUTPUT/AUDIO INPUT is unaffected by the Ratio function.

Displaying the Reference.

When using a currently-displayed measurement result as the ratio reference, that result actually becomes the reference. The only way to read this reference then is to display it via Special Function 11.2.

Display Flicker.

Since displayed measurement results are computed from the actual physical measurements, least-significant digit flicker in the physical measurement can often lead to larger apparent flicker in the displayed result. For example, an AM measurement varying between 50.0% and 50.1% will vary between 100.0% and 100.2% REL with a ratio reference of 50 (or between 0.00 and 0.02 dB after switching to logarithmic units).

dB Ratio.

When using dB ratio; any ratio reference or measurement result that causes ratio M/R (refer to previous equations) to equal 0, results in a display of Error 11 since the log of 0 is undefined.

¹ When μV , mV , or V units are used, this equation provides the ratio result for RF POWER, TUNED RF LEVEL, and RF LEVEL (35.0 SPCL) measurements.

² When watts units are used, this equation provides the ratio result for RF POWER, TUNED RF LEVEL, and RF LEVEL (35.0 SPCL) measurements.

Finer Resolution for dB Measurements³

Special Function 32.1 enables a resolution of 0.001 dB. For audio frequency measurements, this special function enables a resolution of 0.1 Hz for frequencies from 100 to 250 kHz instead of the normally displayed resolution of 1 Hz. The selection of Special Function 32.0 or 32.1 is maintained through instrument power down.

32.0 Power is displayed with the normal measurement resolution of 0.01 dB.

32.1 Power is displayed with a measurement resolution of 0.001 dB.

32.2 Displays 0 if the normal measurement resolution is enabled (32.0 SPCL) and displays 1 if a finer resolution is enabled (32.1).

Use SET REF for Relative Tuned RF Level Measurements.

The SET REF key should be used to make scaled measurements in the Tuned RF Level Measurement mode. (Refer to *Attenuator Measurements* on page 3-115).

Modulation Flatness.

When used in conjunction with track mode tuning, the Ratio function makes checking modulation flatness with respect to RF frequency very convenient. (Refer to *RF Frequency Tuning* on page 3-141 for a discussion of track mode tuning.)

Setting Measurement Limits.

The ratio reference can also be entered as a limit reference. (Refer to *Limit* on page 3-249.)

Common Ratio Measurements.

The following list provides some useful references for common ratio measurements:

- To display broadcast FM deviation relative to the common standard of 75 kHz, use 75 and linear units.
- To display Φ M in degrees, enter a value of 1.745 and select linear units.
- To display AM as dB down from the carrier, enter a value of 200 and select logarithmic units.
- To display rms calibrated average as true average, enter a value of 111.07 and select linear units.
- To display rms calibrated average as peak, enter a value of 70.7 and select linear units.

³ This special function is not available with firmware date codes 234.1985 and below. (To display the firmware date code, select 42.0 SPCL.) To order a ROM set that contains this special function, contact the nearest HP sales office.

Limit

FUNCTIONS

RATIO, Special Function 14 (Limit)

DESCRIPTION

Using Special Function 14 and the RATIO key, lower and upper measurement limits can be entered into the Measuring Receiver. Subsequent out-of-limit measurements will then cause the LIMIT annunciator to light.

When the Limit feature is enabled, the Measuring Receiver can be configured to issue an HP-IB service request upon reaching a lower or upper limit (Refer to the *Remote* section in this manual on page 3-27.) The LIMIT light turns off five measurement cycles after the condition causing limiting is cleared.

Only one lower and one upper limit can be set. Once a limit has been set, it can be used only for that Measurement mode. (However, one limit can be used for one Measurement mode, and the other limit for another Measurement mode.) If, after setting limits, another Measurement mode is selected, the Limit feature is deactivated, but it is restored automatically when the former Measurement mode is re-entered.

Both limit references can be displayed, cleared, and restored; the status of the Limit function can be displayed; and the Measurement modes for which the limits were set can be displayed.

PROCEDURE

To establish a ratio reference and set it as a limit:

First enter the desired limit reference as a ratio reference and then set the lower or upper limit to that ratio reference:

1. Select the Measurement mode for which the limit is to be used.
2. Key in the reference value followed by the RATIO key (Do not use a terminator. The units will stay as currently displayed.) To change the sign of the reference, use the minus (–) key (Blue Key and the decimal point key.)

To set the limits:

3. Set the lower limit (14.1 SPCL) or the upper limit (14.2 SPCL) to the ratio reference.
4. To display the measurement result in absolute units, select RATIO again.

The Special Function codes pertaining to the Limit function are listed in the following table:

	Action	Special Function Code	Program Code ↔ HP-IB ↔
Limit	Clear limits; turn off LIMIT annunciator.	14.0 SPCL	14.0SP
	Set lower limit to RATIO reference.	14.1 SPCL	14.1SP
	Set upper limit to RATIO reference.	14.2 SPCL	14.2SP
	Restore lower limit.	14.3 SPCL	14.3SP
	Restore upper limit.	14.4 SPCL	14.4SP
	Display lower limit.	14.5 SPCL	14.5SP
	Display upper limit.	14.6 SPCL	14.6SP
	Display selected, lower limit measurement code.	14.7 SPCL	14.7SP
	Display selected, upper limit measurement code.	14.8 SPCL	14.8SP
	Display limit status in the format Lower.Upper; where 0=disabled and 1=enabled.	14.9 SPCL	14.9SP

To display the limited measurement mode:

To determine the Measurement mode in which a lower or upper limit is in effect, select 14.7 SPCL or 14.8 SPCL (respectively). The displayed code represents the measurement in which the limit is in effect. These codes are indexed in the following table:

Display	Measurement	Display	Measurement
0.000	AM	0.011	AUDIO FREQ (external)
0.001	FM	2.003	RF LEVEL (35.0 SPCL)
0.002	ϕ M	2.004	PEAK TUNED RF LEVEL (36.0 SPCL)
0.003	RF POWER	2.009	AUDIO DISTN (internal)
0.004	TUNED RF LEVEL	2.010	LO FREQUENCY (33.0 SPCL)
0.005	FREQ	2.011	AUDIO DISTN (external)
0.006	FREQ ERROR	4.009	SINAD (internal)
0.008	IF LEVEL	4.011	SINAD (external)
0.009	AUDIO FREQ (internal)	6.011	EXT AUDIO RMS LEVEL (30.0 SPCL)
0.010	IF FREQUENCY (34.0 SPCL)		

EXAMPLE

To set an upper limit of 75 kHz FM deviation:

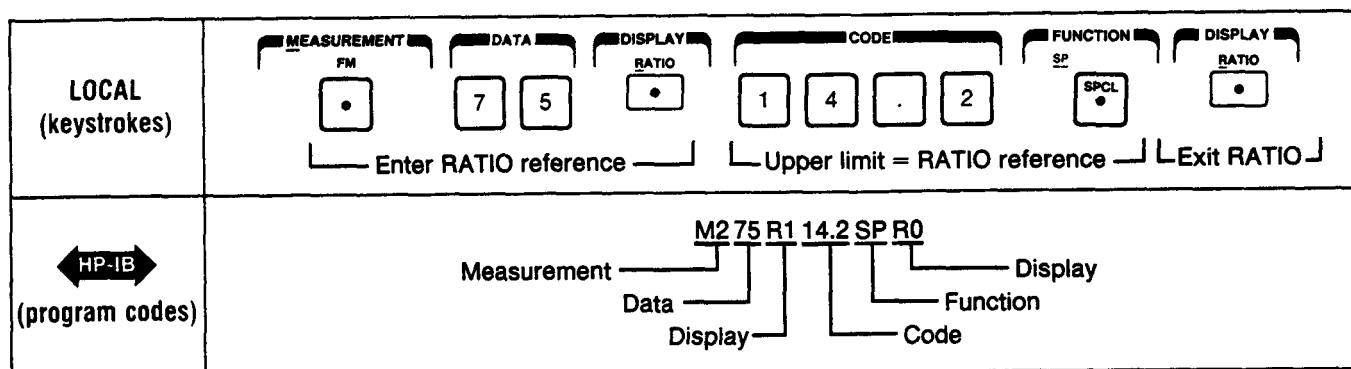

Read the FM deviation in kHz with an upper limit set at 75 kHz.

HP-IB PROGRAM CODES

The codes for performing the various limit operations are provided in "Procedures".

RATIO off = R0

RATIO on = R1

COMMENTS

Relative Limits Not Possible.

The test for out-of-limit results is performed on the actual measurement results, not upon the displayed number. Thus, if the Ratio feature is enabled simultaneously with the Limit feature, the limit test is still based on the measurement result, not the computed ratio. Limits cannot be set in terms of relative measurement results.

Importance of Key Sequence.

If Special Function 14.1 or 14.2 is initiated with no previous numeric value, the ratio reference becomes the entered value. The desired limit must be entered before the Special Function numeric code.

Store/Recall

FUNCTIONS

STORE, RECALL

DESCRIPTION

The Measuring Receiver can store a complete instrument state (including all front-panel functions and most Special Functions) in any of its eight storage registers. The stored data is retained in non-volatile memory when the instrument is off even when the power cord is removed. Any of these stored states can then be re-initiated.

PROCEDURE

To store the current instrument state, select STORE (Blue Key, 7). Then key in a register number (1 through 8).

To recall a previously-stored instrument state, select RECALL (Blue Key, 8). Then key in the desired register number (1 through 8).

HP-IB PROGRAM CODES

RECALL = RC
STORE = TR

COMMENTS

Regarding storage of RF power calibration factors:

- The current reference calibration factor and the frequency/calibration-factor pair can be stored.
- Manual calibration factors can be stored.
- The table of calibration factors cannot be stored with this function, but two tables of calibration factors can be separately stored in the instrument's non-volatile memory. (Refer to *RF Power* under "Comments" on page 3-83.)

Frequency Offset Control

FUNCTIONS

Special Function 27 (Frequency Offset Control)

DESCRIPTION

Using an external mixer and local oscillator (LO) to down-convert the input signal, the frequency range of the Measuring Receiver can be extended into the microwave region. The Frequency Offset mode allows the Measuring Receiver to keep track of the frequencies involved in the down-conversion so the user can be freed from this task. This feature operates for frequencies up to 42 GHz.

The full complement of instrument measurements can be made on the down-converted microwave signal (with the same signal restrictions that apply in the normal frequency range). For best measurement accuracy, the external LO should be a source free from microphonics, residual FM, and drift since these signal impurities translate directly on to the down-converted signal. Use of a synthesized signal source is recommended. Examples of suitable signal sources are the HP 8340A, 8672A, and 8673A.

The RF Power measurement mode uses a separate table of frequencies and calibration factors in the Frequency Offset mode. Frequency entries can range from 0 to 110 GHz. (Refer to *RF Power* on page 3-75 for a procedure for entering calibration factors.)

A rear-panel **FREQ OFST TTL OUT** connector can indicate to external circuits whether the Measuring Receiver is in the Frequency Offset mode and whether the LO is above or below 18 GHz. Use this feature to control external RF switches to route or bypass the input signal between external mixers.

Use Special Function 27 to enter and exit the Frequency Offset mode and to enter and display the LO frequency.

PROCEDURE

To down-convert a microwave input signal into the range of the Measuring Receiver, set an external microwave signal source to a level suitable as an LO for the external mixer. Set the frequency of the external LO source to within 1300 MHz of the microwave input signal. Connect the external LO source to the L port of the external mixer. Connect the microwave input signal to the appropriate input port of the external mixer. Connect the output port of the mixer to the RF INPUT connector or to the input of a sensor module connected to the Measuring Receiver.

Key in 27.3 SPCL then select the LO frequency (in MHz) and select MHz to enter the Frequency Offset mode.

The following table summarizes the various Frequency Offset Control special functions:

Action Regarding Frequency Offset Control	Special Function Code	Program Code HP-IB
Exit Frequency Offset Mode	27.0 SPCL	27.0SP
Re-enter Frequency Offset Mode	27.1 SPCL	27.1SP
Display the External LO Frequency	27.2 SPCL	27.2SP
Enter and Enable the LO Frequency*	27.3 SPCL	27.3SP

*After Special Function 27.3 is entered, enter the frequency of the LO (in MHz) Frequencies from 0 to 40700 MHz can be entered.

Having entered the appropriate LO frequency, either manually tune to the microwave input frequency by pressing the appropriate numeric keys followed by the MHz key or let the Measuring Receiver automatically tune to the input signal.

Perform instrument measurements as usual. Select DISPLAY FREQ (Blue Key, kHz ↑) to display the microwave input frequency.

HP-IB PROGRAM CODES

All HP-IB codes for manipulating the frequency offset control using Special Function 27 are provided in "Procedures".

DISPLAY FREQ = FR
MHz = MZ

MEASUREMENT TECHNIQUE

The external LO mixes with the microwave input signal to create a difference frequency which is the input to the Measuring Receiver. The frequency of the microwave input signal must be within 1300 MHz of the external LO to be within the measurement range of the Measuring Receiver. The LO frequency is manually entered by the operator using Special Function 27.3. The Measuring Receiver, thereafter, uses that LO frequency to compute the microwave input signal frequency regardless of the actual frequency of the LO.

If tuning is in the automatic mode, the Measuring Receiver computes and displays the microwave input frequency as

$$(\text{frequency of LO}) - (\text{frequency at INPUT}).$$

If tuning is manual, the Measuring Receiver computes and displays the microwave input frequency as:

$$(\text{frequency of LO}) \pm (\text{frequency of INPUT}).$$

The difference is computed when the manually-entered frequency is less than the LO frequency. The sum is computed when the frequency is greater. The sense (+ or -) of the math operation remains the same regardless of the actual microwave input frequency, even if automatic tuning is selected.

The displayed frequency is always based on the frequency actually at the Measuring Receiver's input and not the manually-entered input frequency, which serves only to set the Measuring Receiver's internal LO. Manually entering a new microwave input frequency, entering a new LO frequency, or initiating automatic tune always retunes the Measuring Receiver.

When the manually entered LO frequency is displayed (Special Function 27.2), a minus (-) sign preceding the frequency indicates that the math operation is a sum.

COMMENTS

Range Limitations.

If the entered LO frequency and microwave input frequency differ by more than 1300 MHz (or less than 0.15 MHz), an out-of-range error is displayed (Error 10). (Even though the Measuring Receiver appears to measure signals over the range 0 to 110 GHz, the instrument itself can tune to and measure signals only over the range of 0.15 to 1300 MHz. An exception to this is the RF Power measurement.)

Default Condition.

At power-up, the math operation (described under "MEASUREMENT TECHNIQUE") is a difference.

Peak+ and Peak- Functions Reversed.

When FM or Φ M measurements are made, the Peak+ and Peak- functions are reversed whenever the external LO frequency is less than the microwave input frequency.

HP-IB: Service Request Mask.

Using Special Function 22 (bit weight 16), the Measuring Receiver can be unmasked to output a Service Request whenever the Frequency Offset mode changes state (that is, entered or exited) or when the instrument is manually retuned. (Refer to the *Remote* section on page 3-27.)

FREQ OFFSET TTL OUT.

When the Measuring Receiver is in the Frequency Offset mode, the rear-panel FREQ OFFSET TTL OUT connector outputs a voltage which is dependent upon the state of the Frequency Offset mode and the entered external LO frequency. The state of the output is shown in the following table:

State of Frequency Offset Mode	Entered LO Frequency (GHz)	Nominal Voltage at FREQ OFFSET TTL OUT
Out	Any	0
In	0	0
In	>0 but \leq 18	+5
In	>18 but \leq 40.7	+3

Filters, RF and IF

FUNCTIONS

Special Function 3 (RF and IF Filters)

DESCRIPTION

RF Filter.

To eliminate unwanted low-frequency signals in the RF signal path, an RF filter can be inserted. Special Function 3 manually selects the 5.25 MHz High-Pass Filter. Since the IF generally responds to signals below 2.5 MHz, the filter eliminates any low frequencies that might be present on the input. (For input signals between 150 kHz to 10 MHz, the filter should be switched out.)

IF Filters.

The Measuring Receiver down-converts (heterodynes) the RF input to the IF. The IF is usually centered at 1.5 MHz for input signals 10 to 1300 MHz. (An IF of 455 kHz can be manually selected.) For signals between 2.5 MHz and 10 MHz, the IF is 455 kHz. Below 2.5 MHz, the signal is passed directly into the IF without down-conversion (unless the 455 kHz IF has been manually selected). IF filters determine the frequency response of each IF.

When the 1.5 MHz IF is selected, the IF frequency response is determined by the 2.5 MHz Low-Pass (LP) Filter.

When the 455 kHz IF is selected, the Wide 455 kHz Bandpass (BP) Filter determines the IF frequency response, unless a tuned RF level measurement is made which inserts the Narrow 455 kHz BP Filter in series with the other selected IF filter.

Various combinations of these filters can be manually inserted using Special Function 3. (Special Function 3 will override automatic filter selection for Tuned RF level measurements.)

PROCEDURE

To select a desired combination of RF and IF filters, or to re-enter the automatic selection mode, key in the corresponding Special Function code, then press the SPCL key :

Special Function Code	Program Code ↔ HP-IB ↔	IF Frequency	Wide IF Filter	Narrow IF Filter (30 kHz BW)	RF High-Pass Filter (5.25 MHz)
3.0 SPCL	3.0SP	Automatic Selection			OUT
3.1 SPCL	3.1SP	455 kHz	200 kHz BW	OUT	OUT
3.2 SPCL	3.2SP	1.5 MHz	2.5 MHz Low-Pass	OUT	OUT
3.3 SPCL	3.3SP	455 kHz	200 kHz BW	OUT	IN
3.4 SPCL	3.4SP	1.5 MHz	2.5 MHz Low-Pass	OUT	IN
3.5 SPCL	3.5SP	455 kHz	200 kHz BW	IN	OUT
3.6 SPCL	3.6SP	455 kHz	2.5 MHz Low-Pass	IN	OUT
3.7 SPCL	3.7SP	455 kHz	200 kHz BW	IN	IN
3.8 SPCL	3.8SP	455 kHz	2.5 MHz Low-Pass	IN	IN

HP-IB PROGRAM CODES

The HP-IB codes for selecting various combinations of RF and IF filters are provided in "PROCEDURE".

BLOCK DIAGRAM

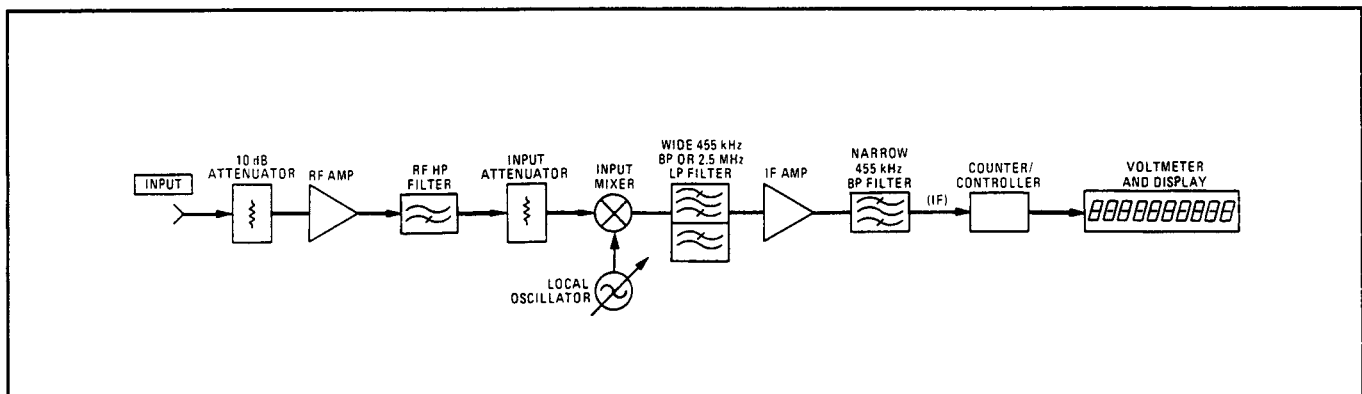

Block Diagram of RF and IF Filters

COMMENTS

Default Condition.

When the instrument is first powered up or when Automatic Operation or Instrument Preset is selected, RF and IF Filters are placed in the automatic selection mode.

Automatic Retuning.

When a new IF is selected, the instrument immediately retunes.

Increased Sensitivity and Selectivity.

Many measurements can typically be made on very low-level signals. Using the narrow bandwidth of the 455 kHz IF for signal frequencies less than 2.5 MHz (but in the manual down-convert mode) or greater than 10 MHz increases the sensitivity and selectivity of the Measuring Receiver. (There are, however, restrictions on modulation, and measurement accuracy may decrease.) Manual deletion of RF input attenuation or insertion of gain also increases sensitivity. (Refer to *RF Input Attenuation and Gain* on page 3-265.)

IF Gain

FUNCTIONS

Special Function 9 (IF Gain)

DESCRIPTION

For Tuned RF Level measurements, the Measuring Receiver uses a programmable IF amplifier. The amplifier has precise 10 dB gain steps ranging from 0 to 60 dB. The amplifier is automatically inserted and programmed in the Tuned IF Level measurement mode for either the IF Synchronous or IF Average detector. For other measurements, the IF amplifier is bypassed.

Special Function 9 permits manual selection of the IF amplifier and can be used with tuned measurements other than tuned RF level.

PROCEDURE

To manually set the IF gain, or to re-enter the automatic selection mode, key in the corresponding Special Function code followed by SPCL.

IF Gain (dB)	Special Function Code	Program Code ↔ HP-IB ↔
Automatic Selection	9.0 SPCL	9.0SP
0	9.1 SPCL	9.1SP
10	9.2 SPCL	9.2SP
20	9.3 SPCL	9.3SP
30	9.4 SPCL	9.4SP
40	9.5 SPCL	9.5SP
50	9.6 SPCL	9.6SP
60	9.7 SPCL	9.7SP

HP-IB PROGRAM CODES

All HP-IB codes for selecting IF gain ranges are provided in "PROCEDURE".

COMMENTS

Default Condition.

When the instrument is first powered up, or when Automatic Operation or Instrument Preset is selected, the IF Gain function is placed in the automatic selection mode. (The gain will usually change when a different IF detector is selected.)

Multiple Uses of IF Amplifier.

The design of the programmable IF amplifier is optimized for the Tuned RF Level measurement mode which uses the 455 kHz IF. The amplifier, although not specified, can be used for all tuned measurements and IF frequencies to improve measurement sensitivity. (Refer to the block diagram in *Tuned RF Level* on page 3-103 to aid in visualizing the function of the IF amplifier.)

Measurement Degradation.

Increasing the IF gain for measurements other than Tuned RF Level would degrade performance. Degradation is most evident at high modulation rates, high IF gain, or IF frequencies other than 455 kHz.

IF Gain Change.

The IF gain will generally change when a different IF detector is selected.

RF Input Attenuation and Gain

FUNCTIONS

Special Function 1 (RF Input Attenuation and Gain)

DESCRIPTION

The RF input attenuation and gain is usually automatically selected but can be manually set by keyboard entry using Special Function 1.

PROCEDURE

To set the input attenuation/gain to a selected range, or to enter an automatic selection mode, key in the corresponding special function code, then select SPCL:

RF Input Attenuation		Special Function Code	Program Code ↔ HP-IB ↔
RF Gain	RF Attenuation		
Automatic Selection	Automatic Selection	1.0 SPCL	1.0SP
0 dB	0 dB	1.1 SPCL	1.1SP
	10 dB	1.2 SPCL	1.2SP
	20 dB	1.3 SPCL	1.3SP
	30 dB	1.4 SPCL	1.4SP
	40 dB	1.5 SPCL	1.5SP
	50 dB	1.6 SPCL	1.6SP
24 dB	0 dB	1.7 SPCL	1.7SP
24 dB	10 dB	1.8 SPCL	1.8SP
Automatic Selection	Automatic Selection with 10 dB attenuation always inserted*	1.9 SPCL	1.9SP

* For Tuned RF Level Measurements only.

COMMENTS

Default Condition.

When the Measuring Receiver is first powered up, or when Automatic Operation or Instrument Preset is selected, the RF input attenuation/gain is placed in the automatic selection mode (Special Function 1.0).

Error 02, 03.

If the RF input attenuation/gain is manually set to a range that causes the input signal level to overdrive the input mixer, Error 02 is displayed. If the RF input attenuation/gain is manually set so the signal level reaching the IF circuits is too low for accurate measurements, Error 03 is displayed.

Manual Settings Not Allowed with RF Level Measurements.

Manual setting of RF input attenuation/gain is overridden when RF Level measurements are selected.

Special Function 1.9.

When Special Function 1.9 (the alternate automatic selection) has been selected, the displayed special function suffix in the Special Display will differ from that suffix displayed in the Special Special Display. (Refer to *Special Functions* on page 3-272 for a description of these two types of display.) When the Special Display is initiated, 9 will be the first suffix. When the Special Special Display is initiated, the automatically-selected suffix will be displayed.

Increase Measurement Ability on Low Level Signals.

Use input gain (Special Functions 1.6 and 1.7 that insert the RF Amp) in conjunction with IF gain (Special Function 9) to make general, unspecified RF and audio measurements on low-level signals. Only use input gain for input signal frequencies greater than 1 MHz. The RF and IF Amplifiers could also contribute distortion and noise to the measurements. (Refer to *IF Gain* on page 3-263.)

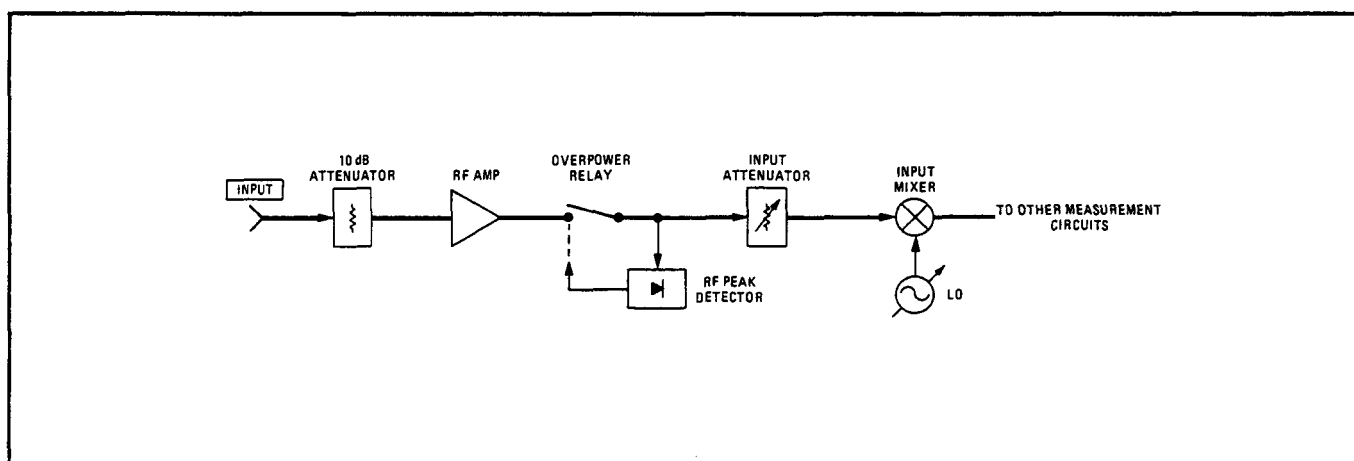

Block Diagram of RF Input Attenuation and Gain

Error Message Disable Control

FUNCTIONS

DISABLE ERROR, Special Function 8 (Error Message Disable and Enable)

DESCRIPTION

Error Messages are one means the Measuring Receiver uses to safeguard measurement integrity. When the instrument senses a potential error-causing situation, an Error Message code is displayed to alert the user of the condition. The Error Message code indexes an Error Message, which describes the current errors. (Refer to *Error Message Summary* on page 3-285.)

When the Measuring Receiver is in its Automatic Operation mode, Error Messages are selectively enabled, depending on the measurement being made, to assure the broadest range of calibrated measurements. Some Error Messages, however, can be selectively disabled or enabled using Special Function 8. Disable Error performs the same function as Special Function 8.7 (Errors 01, 02, 03, and 04 disabled).

Most combinations of Errors 01 through 04 can be disabled or enabled by the operator to customize the behavior of the instrument to meet a particular set of measurement requirements. Special Function 8.8 (Errors 01 through 04 enabled) sets up the Measuring Receiver as a calibrated receiver. (Refer to "COMMENTS" for further elaboration.)

The following table lists the Error Messages conveyed by Errors 01 through 04:

Error	Error Message
01	Signal out of IF range
02	Input circuits overdriven
03	Input circuits underdriven
04	Audio circuits overdriven

The following table lists the errors that are automatically disabled in each Measurement mode:

Measurement Selected	Errors Disabled When in Automatic Selection Mode (Special Function 8.0)
AM	None
FM	None
ϕ M	None
RF POWER	01, 04
FREQ	02, 03, 04
AUDIO FREQ	None
AUDIO DISTN	None
IF LEVEL	01, 02, 03, 04
TUNED RF LEVEL	02, 03, 04
FREQ ERROR	01, 02, 03, 04
SINAD (Special Function 29.0)	None
EXT AUDIO RMS LEVEL (Speical Function 30.0)	None
LO FREQUENCY (Special Function 33.0)	01, 02, 03, 04
IF FREQUENCY (Special Funciton 34.0)	01, 02, 03, 04
RF LEVEL (Special Function 35.0)	01, 04
PEAK TUNED RF LEVEL (Special Function 36.0)	02, 03, 04

PROCEDURES

To disable Errors 01, 02, 03, and 04, select **DISABLE ERROR** (Blue Key, RANGE HOLD). This key selection enables 8.7 SPCL.

To selectively enable or disable combinations of Errors 01 through 04, enter the Special Function code that corresponds to the condition desired, then select SPCL. The codes for the various conditions are listed in the following table:

Error Condition	Special Function Code	Program Code 
Automatic Selection	8.0 SPCL	8.0SP
01 disabled	8.1 SPCL	8.1SP
02 and 03 disabled	8.2 SPCL	8.2SP
01, 02, and 03 disabled	8.3 SPCL	8.3SP
04 disabled	8.4 SPCL	8.4SP
01 and 04 disabled	8.5 SPCL	8.5SP
02, 03, and 04 disabled	8.6 SPCL	8.6SP
01, 02, 03, and 04 disabled	8.7 SPCL	8.7SP
01, 02, 03, and 04 enabled	8.8 SPCL	8.8SP

HP-IB PROGRAM CODES

The HP-IB program codes for selectively disabling combinations of Errors 01 through 04 are provided in "PROCEDURE".

DISABLE ERROR = B1

Clear DISABLE ERROR function = B0

COMMENTS

Input/Output Status

When Error Messages are disabled, the accuracy of the displayed measurement and the fidelity of the signal at the output of the MODULATION OUTPUT/AUDIO INPUT are not safeguarded. When all the errors are enabled, displayed results are calibrated and the output of MODULATION OUTPUT/AUDIO INPUT is entirely safeguarded.

Disable Error 04 Inhibits Audio Autoranging

When Error 04 is disabled, the Measuring Receiver automatically ranges to a less sensitive range when the signal level requires, but it does not range back when the audio level is reduced. Thus, if a transitory peak audio signal is detected, the Measuring Receiver will up-range the audio range to accommodate the peak but will not down-range after it has passed. Audio autoranging is then prevented from interfering with other measurements such as input frequency. (Refer to *Audio Range* on page 3-211.)

Special Function 8 Overrides Automatic Selection

Note that Special Functions 8.1 through 8.8 override the automatic selection for all measurement modes. Thus, error messages that may be appropriately disabled for one measurement mode (such as frequency) may be inappropriate for another measurement mode (such as AM).

Limits to Disabling Error Messages

Disabling some error messages (such as Error 04) often give rise to other error messages that cannot be disabled (such as Error 07).

Safeguarding the Signal Fidelity at the Modulation Output

Special Function 8.8 is sometimes referred to as the "calibrated receiver" mode of operation. It assures that the output from MODULATION OUTPUT/AUDIO INPUT is safeguarded for most measurements. Some tuned, non-modulation measurement modes (such as frequency) do not completely safeguard the signal fidelity at this output since accurate demodulation is not the primary goal of that measurement mode.

Identify Currently Disabled Error Messages

Use the Special Display and the Special Special Display to identify currently disabled error messages. (Refer to *Special Functions* on page 3-272.)

Special Functions

FUNCTIONS

All Special Functions prefixed 1 to 39

DESCRIPTION

General Information.

Special functions enable extended use of the instrument beyond the control normally available from dedicated front-panel keys. The special functions are best used after a thorough understanding of the instrument is grasped.

Special functions are accessed via keyboard entry of the appropriate numeric code terminated by the SPCL key. (Refer to "Procedures".) The codes comprise a prefix, decimal, and suffix. Special functions are disabled in different ways, depending on the function. Refer to the following comprehensive table for actions which clear or disable any special function. Special functions are grouped by their prefixes into three categories as follows:

Prefix 0

Prefix 0 is the Direct Control Special Function intended for use in servicing the Measuring Receiver (discussed in detail in Section 8). All instrument error messages and safeguards are inactive. If the Direct Control Special Function is entered inadvertently, press AUTOMATIC OPERATION.

Prefixes 1 to 39

Prefixes 1 to 39 are the User Special Functions that are used during normal instrument operation when a special configuration, a special measurement, or special information is required. All error messages and most safeguards remain in effect unless the operator disables them. These special functions are described in the table in this instruction.

Prefixes 40 to 99

Prefixes 40 to 99 are the Service Special Functions used to assist in troubleshooting an instrument fault (discussed in detail in Section 8). The functions available include special internal measurements, software control, and special service tests and configurations. Most instrument safeguards are relinquished. If a Service Special Function is entered inadvertently, press AUTOMATIC OPERATION. Repair personnel can gain arbitrary control of the instrument as an aid in troubleshooting.

Viewing Special Function States

In addition to completing the entry of special function codes, the SPCL key enables viewing of some special function settings. The operator-requested settings of Special Functions prefixed 1 through 10 can be viewed by pressing the SPCL key once (following no numeric entry). This display is called the Special Display. If some of these Special Functions are in automatic modes (generally the 0-suffix setting), the actual instrument settings of these functions can be displayed by pressing the SPCL key a second time while the Special Display is still active. This display is called the Special Special Display. Both displays can be disabled by pressing any key except the Blue Key, LOCAL, or S (shift) key. (While either display is active, pressing the SPCL key selects the other display.)

A summary of User Special Functions is provided at the end of this instruction. Also included in this instruction are procedures for initiating special functions and for obtaining the Special Display and the Special Special Display.

PROCEDURES

Entering Special Functions.

To use a special function, key in the corresponding code, then select SPCL.

Special Display.

To display the user-requested modes of special functions prefixed 1 through 10, select SPCL alone one time. The digit position (noted beneath the display) corresponds to the special function prefix, and the number displayed in that position corresponds to the special function suffix.

Special Special Display.

To determine the actual instrument settings corresponding to special functions prefixed 1 through 10, press the SPCL key alone once while the Special Display is active. (If the Special Display is not active, press the SPCL key twice to get this display.) The digit position corresponds to the special function prefix, and the number displayed in that digit corresponds to the special function suffix.

HP-IB PROGRAM CODES

All special function codes are formed by the special function number followed by the code "SP". For example, the code for Special Function 7.3 is "7.3SP".

For special function codes with zero as a suffix, force a single space if the zero is to be omitted. For example, "10.0SP" could be "10. SP"

EXAMPLES

Entering Special Functions.

To display the frequency of the signal in the IF (Special Function 34):

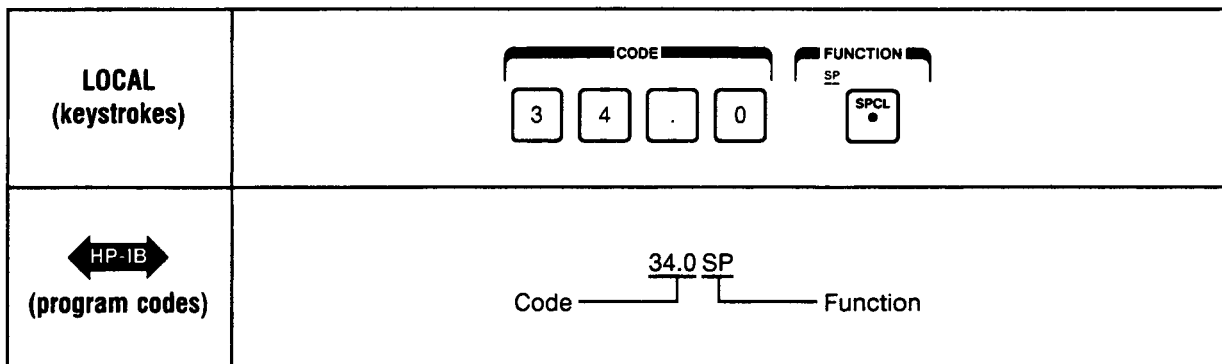

Viewing the Special Display.

When SPCL is pressed alone once, the following display might result:

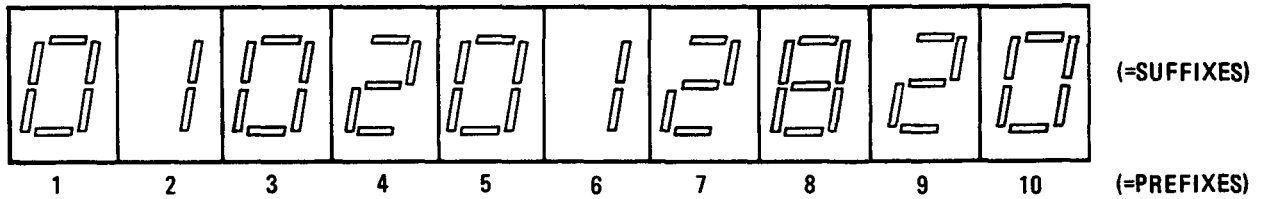

This display is interpreted as follows:

Special Function		User-Requested Setting
Code	Name	
1.0	RF Input Attenuation and Gain	Automatic Selection
2.1	Audio Range	40% AM; 4 kHz FM; 4 radians ϕ M
3.0	RF and IF Filters	Automatic Selection (RF High-Pass Filter Out)
4.2	Tuned RF Level Detector Selection and Display Averaging	If Synchronous Detector with 1 Second Averaging Time
5.0	Audio Detector Response	Fast Response
6.1	Automatic Level Control	Fast Response
7.2	RF Frequency Resolution	100 Hz
8.8	Error Message Disable	All Errors Enabled
9.2	IF Gain	10 dB IF Gain
10.0	RF Power Range	Automatic Selection

Special Special Display.

When SPCL is pressed again, the following display might result: (The user-selected Special Functions shown in the previous example are repeated in the Special Special Display. The Special Functions that were left in the automatic selection mode will display the suffix that was automatically selected.)

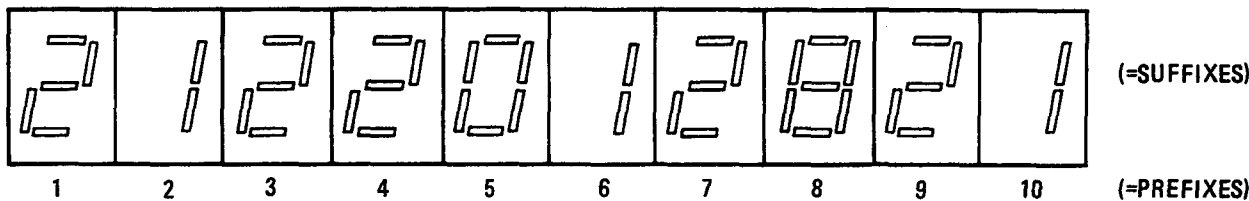

The display is interpreted as follows:

Special Function		Actual Instrument Setting
Code	Name	
1.2	RF Input Attenuation and Gain	10 dB Attenuation
2.1	Audio Range	40% AM; 4 kHz FM; 4 radians ϕ M
3.2	RF and IF Filters	1.5 MHz IF Frequency; 2.5 MHz IF Bandwidth; Narrow Filter Out; RF High-Pass Filter Out
4.2	Tuned RF Level Detector Selection and Display Averaging	If Synchronous Detector with 1 Second Averaging Time
5.0	Audio Detector Response	Fast Response
6.1	Automatic Level Control	Fast Response
7.2	RF Frequency Resolution	100 Hz
8.8	Error Message Disable	All Errors Enabled
9.2	IF Gain	10 dB IF Gain
10.1	RF Power Range	Range #1

COMMENTS

Omit Zero Suffixes.

If a special function has a suffix of zero, the zero need not be entered. For example, 10.0 SPCL equals 10.SPCL. (However, 22.2 SPCL does not equal 22.20 SPCL nor does 18.1 SPCL equal 18.10 SPCL.) If entering a special function code evokes Error 21 (invalid key sequence), the special function requested has not been executed.

HP-IB.

Force a single space in "10. SP" if the zero is to be omitted.

CLEAR Key.

If an error is made while keying in the special function code, select CLEAR and re-enter the code.

Incongruity Between Special and Special Special Display.

In most cases, the user-selected special function suffix appears in both the Special Display and the Special Special Display. However, Special Functions 1.9 and 4.4 are user-selected, automatic-selection modes, and might display a different suffix in the Special Special Display.

DETAILED DESCRIPTIONS OF ALL SPECIAL FUNCTIONS

1. RF Input Attenuation and Gain. Use this special function to select RF input attenuation or amplification to eliminate input overload or to improve measurement sensitivity. For more details about this function, refer to *RF Input Attenuation and Gain* on page 3-265.

- 1.0 Automatic selection
- 1.1 Attenuation of 0 dB
- 1.2 Attenuation of 10 dB
- 1.3 Attenuation of 20 dB
- 1.4 Attenuation of 30 dB
- 1.5 Attenuation of 40 dB
- 1.6 Attenuation of 50 dB
- 1.7 Gain of 24 dB
- 1.8 Gain of 14 dB (24 dB gain with 10 dB attenuation)
- 1.9 Automatic selection with 10 dB attenuation always inserted (usually only used in Tuned RF Level measurements)

2. Audio Range Selection. Use this special function to set the display resolution for modulation measurements. The Measuring Receiver's display resolution is dependent on the modulation being measured and the detector being used. For example, in FM measurements, Special Function 2.4 can only display 0.01 Hz resolution when the deviation being measured is less than 0.04 peak kHz and when the RMS detector is selected. Because this special function is so complex, it is not described in detail here. Refer to *Audio Range* on page 3-211, for detailed tables for this function.

3. RF and IF Filters. Use this special function to change the Measuring Receiver's RF and IF filters. (Refer to *Filters, RF and IF* on page 3-259 for information about the usefulness of changing these filters.)

Special Function Code	Program Code ↔ HP-IB ↔	IF Frequency	Wide IF Filter	Narrow IF Filter (30 kHz BW)	RF High-Pass Filter (5.25 MHz)
3.0 SPCL	3.0SP	Automatic Selection			OUT
3.1 SPCL	3.1SP	455 kHz	200 kHz BW	OUT	OUT
3.2 SPCL	3.2SP	1.5 MHz	2.5 MHz Low-Pass	OUT	OUT
3.3 SPCL	3.3SP	455 kHz	200 kHz BW	OUT	IN
3.4 SPCL	3.4SP	1.5 MHz	2.5 MHz Low-Pass	OUT	IN
3.5 SPCL	3.5SP	455 kHz	200 kHz BW	IN	OUT
3.6 SPCL	3.6SP	455 kHz	2.5 MHz Low-Pass	IN	OUT
3.7 SPCL	3.7SP	455 kHz	200 kHz BW	IN	IN
3.8 SPCL	3.8SP	455 kHz	2.5 MHz Low-Pass	IN	IN

4. Tuned RF Level Synchronous and Average Detector and Display Averaging. Tuned RF level measurements can be made with one of two internal detectors: a narrow-band tracking IF synchronous detector or a wider-band IF average detector. The IF synchronous detector is more sensitive than the IF average detector but the IF average detector is more tolerant of signal drift and residual FM than the average detector. When measuring noisy signals, use the IF average detector (4.4 SPCL). The IF synchronous detector (4.0 SPCL) is automatically selected on power-up.

Measurement averaging time is automatically selected by the Measuring Receiver during the Tuned RF Level measurement when 4.0 SPCL or 4.4 SPCL is selected. The Measuring Receiver chooses these times based on the requirements of its internal circuitry. However, experienced operators may want to increase or decrease the measurement time using Special Function 4.

4.0 Synchronous detector; averaging time is automatic.

4.1 Synchronous detector; averaging time is 10s.

4.2 Synchronous detector; averaging time is 1s.

4.3 Synchronous detector; averaging time is 0.1s.

4.4 Average detector; averaging time is automatic.

4.5 Average detector; averaging time is 10s.

4.6 Average detector; averaging time is 1s.

4.7 Average detector; averaging time is 0.1s.

5. Audio Detector Response. Use this special function to help stabilize measurements on unstable or noisy signals when making modulation or SINAD measurements.¹

5.0 Fast response time.

5.1 Slow response time.

6. Automatic Level Control. Use this special function to speed up the ALC response time or to disable the ALC. (The faster ALC response time degrades AM accuracy at rates less than 1 kHz.) Disabling the ALC, in conjunction with the rear-panel AM Output connector, can be used to measure AM at very low modulation rates. Disabling the ALC also permits measurement of absolute changes in AM depth without regard to changes in carrier level.

6.0 Slow ALC (for AM rates greater than 20 Hz).

6.1 Fast ALC (for AM rates greater than 1 kHz).

6.2 ALC off.

¹ The slow response time for SINAD is not available with firmware date codes 234.1985 and below. (To display the firmware date code, select 42.0 SPCL.) To order a ROM set that contains this special function, contact the nearest HP sales office.

7. RF Frequency Resolution. Use this special function to manually set the display resolution during frequency measurements (including RF, IF, and LO frequencies). Note that with finer resolution, measurement time increases .

- 7.0 Automatic selection.
- 7.1 Resolution of 10 Hz.
- 7.2 Resolution of 100 Hz. (When using an external LO value greater than 20 GHz, 7.1 SPCL selects 100 Hz resolution.)
- 7.3 Resolution of 1 kHz.
- 7.4 ² (Applies to RF Frequency measurements only; other measurements treat 7.4 as 7.1.) Resolution of 0.1 Hz for input signals less than 10.1 MHz; resolution of 1 Hz for signals from 10.1 MHz through 1300 MHz. (When measuring frequencies as high as 1300 MHz, measurement time with this resolution is approximately 20 seconds.)

8. Error Message Disable Control. Most combinations of Errors 01 through 04 can be disabled or enabled to customize the behaviour of the instrument to meet a particular set of measurement requirements. When the Measuring Receiver uses automatic selection of error messages, these messages are selectively enabled, depending on the measurement being made, to assure the broadest range of calibrated measurements. *Error Message Disable Control* on page 3-267 has a table that lists the errors that are automatically disabled during each measurement.

- 8.0 Automatic selection of disabled error messages.
- 8.1 Disables Error 01.
- 8.2 Disables Errors 02 and 03.
- 8.3 Disables Errors 01, 02, and 03.
- 8.4 Disables Error 04.
- 8.5 Disables Errors 01 and 04.
- 8.6 Disables Errors 02, 03, and 04.
- 8.7 Disables Errors 01, 02, 03, and 04. Performs the same function as DISABLE ERROR (Blue Key, RANGE HOLD).
- 8.8 Enables Errors 01, 02, 03, and 04. This ensures that the output from MODULATION OUTPUT is safeguarded for most measurements. Some tuned, non-modulation measurement modes (such as frequency) do not completely safeguard the signal fidelity at this output since accurate demodulation is not the primary goal of that measurement mode.

9. IF Gain. Use this special function to insert gain into the Measuring Receiver's circuitry. The amplifier used has precise 10 dB gain steps ranging from 0 to 60 dB. (Refer to *IF Gain* on page 3-263 for more information about this function.)

- 9.0 Automatic Selection of gain for Tuned RF Level measurements.
- 9.1 Gain of 0 dB inserted.
- 9.2 Gain of 10 dB inserted.
- 9.3 Gain of 20 dB inserted.
- 9.4 Gain of 30 dB inserted.
- 9.5 Gain of 40 dB inserted.
- 9.6 Gain of 50 dB inserted.
- 9.7 Gain of 60 dB inserted.

² This special function is not available with firmware date codes 234.1985 and below. (To display the firmware date code, select 42.0 SPCL.) To order a ROM set that contains this special function, contact the nearest HP sales office.

10. RF Power Range. Use this special function to manually select one of the five internal power ranges. In most applications, the Measuring Receiver will automatically select the appropriate power range. The following table lists the power ranges and their associated special function codes.

- 10.0 Automatic selection.
- 10.1 Range #1 (most sensitive range).
- 10.2 Range #2.
- 10.3 Range #3.
- 10.4 Range #4.
- 10.5 Range #5 (least sensitive range).

11.2. Previous Ratio. Use this special function to display the reference set with the RATIO key.

12. FM Calibration for Another Instrument in the HP 8902 and HP 8902 RF Signal Analyzer Family. Use this special function to compute an FM calibration factor for another RF signal analyzer that has no internal calibrator, or that has an internal calibrator that is to be cross checked. (For a complete procedure for FM calibration, refer to *FM Calibration* on page 3-181.)

- 12.0 Display the computed peak FM.
- 12.1 Display the demodulated peak residual FM.
- 12.2 Display the demodulated peak FM.

13. AM Calibration for Another Instrument in the HP 8902 and HP 8902 RF Signal Analyzer Family. Use this special function to compute an AM calibration factor for another RF signal analyzer that has no internal calibrator, or that has an internal calibrator that is to be cross checked. (For a complete procedure for AM calibration, refer to *AM Calibration* on page 3-167.)

- 13.0 Display the computed peak AM.
- 13.1 Display the demodulated peak residual AM.
- 13.2 Display the demodulated peak AM.

14. Measurement Limits. Use this special function in conjunction with the RATIO key to set lower and upper measurement limits. (For a complete procedure on setting measurement limits, refer to *Limit* on page 3-249.)

- 14.0 Clear limits; turn off LIMIT annunciator.
- 14.1 Set a lower limit to the Ratio reference.
- 14.2 Set an upper limit to the Ratio reference.
- 14.3 Restore the lower limit.
- 14.4 Restore the upper limit.
- 14.5 Display the lower limit.
- 14.6 Display the upper limit.
- 14.7 Display the code for the measurement the lower limit applies to.
- 14.8 Display the code for the measurement the upper limit applies to.
- 14.9 Display the limit status in the format "Lower.Upper" where 0=disabled and 1=enabled.

15. Time Base Check. Use this special function to check the status of the time base being used by the Measuring Receiver. (More information about the time base is on page 3-3.)

15.0 Display whether the internal, Option 002 time base oven is warm enough to create a stable source; 0 = warm. Error 12 is displayed if the time base is cold.

15.1 Display whether the internal or external time base is being used; 0 = internal and 1 = external.

16. AM Calibration Factor. This special function enables you to disable, enable, or display the current AM calibration factor. Front-panel keys SAVE CAL (Blue Key, CALIBRATE) and % CAL FACTOR (Blue Key, MHz) can also be used to enable and display the calibration factor. (For a complete procedure for AM calibration, refer to *AM Calibration* on page 3-167.)

16.0 Disable the AM calibration factor.

16.1 Enable the AM calibration factor.

16.2 Display the AM calibration factor. (Displays 0 if not enabled.)

17. FM Calibration Factor. This special function enables you to disable, enable, or display the current FM calibration factor. Front-panel keys SAVE CAL (Blue Key, CALIBRATE) and % CAL FACTOR (Blue Key, MHz) can also be used to enable and display the calibration factor. (For a complete procedure for FM calibration, refer to *FM Calibration* on page 3-181.)

17.0 Disable the FM calibration factor.

17.1 Enable the FM calibration factor.

17.2 Display the FM calibration factor. (Displays 0 if not enabled.)

18. NN Tone Burst Receiver. Use this special function to measure the frequency of squelch tones. A time delay of NN ms is inserted between detection of a carrier and unsquelching of the output at the MODULATION OUTPUT connector. The range of NN is 1 to 99 ms. If NN is 0, the delay is 99 ms. (Refer to *Tone Burst Receiver* on page 3-193 for more information about this function.)

21. HP-IB Address. Use this special function to display the HP-IB address in the form:

AAAAAAA.TLS., where:

AAAAAAA is the address in binary,

T = 1 = talk only,

L = 1 = listen only, and

S = 1 = requesting service.

22. Service Request. Use this special function to set up a service request mask. A value of NN from 0 to 63 sums the weighted conditions below to set up a service request mask. The summed, weighted conditions are displayed when NN is 64. Refer to page 3-30 for more information about this service request mask.

1 Data ready

2 HP-IB error (cannot be disabled)

4 Instrument error

8 Limit exceeded

16 Frequency Offset mode state change

32 RECAL or UNCAL

64 read back SRQ mask

23. External LO (Option 030 Only). Use this special function when making Selective Power Measurements using an external LO. (Refer to *Selective Power Measurements* on page 3-119 for more information about this measurement.)

23.0 Return the LO to internal.

23.1 Set the LO to external.

23.2 Display the status of the LO (0=Internal, 1=External).

24. Selective Power Measurement (Option 030 Only). Use this special function when measuring adjacent channel power or single-sideband noise. (Refer to *Selective Power Measurements* on page 3-119 for more information about this measurement.)

24.0 Sets the Measuring Receiver to the Selective Power Measurement Mode.

24.1 Selects the wide-bandwidth IF filter for adjacent-channel or cellular radio power measurements; displays the IF level (in volts).

24.2 Establishes the level measured with 24.1 SPCL as the 0 dB reference.

24.3 Selects a narrower bandwidth IF filter than 24.1 SPCL for adjacent-channel power measurements; displays the IF level (in volts).

24.4 Establishes the level measured with 24.3 SPCL as the 0 dB reference.

24.5 Selects a very narrow bandwidth IF filter (2.5 kHz) for the single-sideband noise measurement; displays the IF level (in volts).

24.6 Establishes the level measured with 24.5 SPCL as the 0 dB reference.

24.7 Displays the noise measurement as normalized to a 1 Hz bandwidth.

24.8 Enables setting of the value of the noise measurement bandwidth.

24.9 Displays the value of the noise measurement bandwidth.

25. Current Value of External Attenuation. Use this special function in conjunction with dB EXT ATTEN (Blue Key, LOG/LIN) to scale level measurements to correctly indicate the power at the input of an external attenuator or amplifier connected to the Measuring Receiver. (For information on setting the value of external attenuation or gain, refer to *External Attenuation* on page 3-131.)

25.2 Display the current offset in dB. (Amplification is shown as a negative attenuation value.)

26. Relative Tuned RF Level Measurement. Use this special function in conjunction with SET REF (Blue Key, ZERO) to make relative Tuned RF Level measurements. (Refer to *Attenuator Measurements* on page 3-115 for more information about this function.)

SET REF Enter the relative Tuned RF Level measurement mode and set the input signal level as 0 dB.

26.0 Exit the relative Tuned RF Level measurement mode and enter the absolute Tuned RF Level measurement mode.

26.1 Re-enter the relative measurement mode using the previous reference set with SET REF.

27. Frequency Offset Control. Use this special function when making measurements on down-converted input signals. (The Measuring Receiver can measure frequencies to 42 GHz when an external mixer and LO are used to down-convert the input signal. Refer to *Frequency Offset Control* on page 3-255 for requirements of the local oscillator and mixer.) The Frequency Offset Control special function allows the Measuring Receiver to keep track of the frequencies involved in the down-conversion.

27.0 Exit the Frequency Offset Mode.

27.1 Enter the Frequency Offset Mode.

27.2 Display the external LO frequency.

27.3 Prepare to enter and enable the LO frequency. After entering 27.3 SPCL, enter the frequency of the LO (in MHz). Frequencies from 0 to 40700 MHz can be entered.

29.0 SINAD Measurement. Use this special function to make SINAD (Signal to Noise And Distortion) measurements on either internally demodulated signals or externally applied audio signals.

30.0 External Audio RMS Level Measurement. Use this special function to measure the true rms level of an audio signal applied to the Measuring Receiver's AUDIO INPUT connector.

31. Tuned RF Level Noise Correction. ³ Use this special function in conjunction with the IF Average Detector (Special Functions 4.4 through 4.7) when making Tuned RF Level measurements on low-level signals. The selection of Special Function 31 is maintained through instrument power down (the Measuring Receiver being turned off and then on).

The Tuned RF Level measurement calibrates three RF input attenuation ranges to achieve accurate low-level measurements. (The *Operating Information Pull-Out Card* illustrates these.) When Special Function 31.1 is enabled, the normal Tuned RF Level measurement procedure is followed (that is, stepping down in level and pressing the CALIBRATE key whenever the RECAL annunciator is displayed). However, when the Measuring Receiver calibrates the third RF range, it causes the sensor module to switch out the signal from the device-under-test momentarily (placing 50 Ω at the output). Then the HP 8902A measures the noise between the RF input and the IF Average Detector circuitry. In subsequent measurements (in this third range), the Measuring Receiver subtracts the measured noise from the total signal-plus-noise to display the measured signal level.

31.0 Turn off noise correction.

31.1 Turn on noise correction.

31.2 Display 0 if noise correction is off and display 1 if it is on.

³ This special function is not available with firmware date codes 234.1985 and below. (To display the firmware date code, select 42.0 SPCL.) To order a ROM set that contains this special function, contact the nearest HP sales office.

COMMENTS ABOUT SPECIAL FUNCTION 31:

NOTE

Special Function 31.1 (for noise correction) should be entered once before making level measurements. To clear Special Function 31.1 you MUST enter 31.0 SPCL.

Special Function 31 can be especially useful when making measurements on down-converted signals. Special Functions 31.0 and 31.1 can be toggled once the Tuned RF Level calibration has been done with 31.1 enabled. That is, the signal can be measured alternately with the noise added to the signal and without the noise.

The Measuring Receiver uses a default noise value (that might be invalid) in its measurement response if Special Function 31.1 is enabled after (instead of before) completing the Tuned RF Level calibration sequence. (The default noise value is the last value that was measured. This value is saved through Instrument Preset and power down.)

CAUTION

Do not use 31.1 SPCL when making any uncalibrated, or relative signal level measurement in Tuned RF Level mode without a power sensor. The Sensor Module must be used when making Tuned RF Level range-to-range calibrations with the AVG Detector.

32. dB and Frequency Resolution. ⁴ During RF Power and Tuned RF Level measurements, and measurements that use the Ratio function, use this special function to display dB measurements with resolution in 0.001 dB instead of the normally displayed resolution of 0.01 dB. During audio measurements, use this special function to display 0.1 Hz resolution from 100 to 250 kHz. The selection of Special Function 32.0 or 32.1 is maintained through instrument power down (the Measuring Receiver being turned off and then on). (Note that Special Functions 32.1 and 32.9 can be enabled simultaneously.)

32.0 Power is displayed with normal measurement resolution of 0.01 dB.

Audio frequency is displayed with the normal resolution of 1 Hz for frequencies from 100 to 250 kHz.

32.1 Power is displayed with measurement resolution of 0.001 dB.

Audio frequency is displayed with a resolution of 0.1 Hz for frequencies from 100 to 250 kHz.

32.2 Displays 0 if the normal measurement resolution is enabled (32.0 SPCL) and displays 1 if a finer resolution is enabled (32.1 SPCL).

32.9 Tuned RF Level Measurements Using Track-Mode Tuning. ⁵ Use this special function when making level measurements on low-level signals (greater than 40 MHz into the HP 8902A) that tend to drift. The track mode tuning is available only with the IF average detector (Special Functions 4.4 through 4.7) which can measure levels to -110 dBm). (Note that Special Functions 32.1 and 32.9 can be enabled simultaneously.)

To select track-mode tuning for a low-level Tuned RF Level measurement:

- a. Instrument Preset the HP 8902A (blue key, green key).
- b. If using a down converter to measure microwave signals, key in 27.3 SPCL. Key in the external L.O. frequency. Make sure that the L.O. frequency results in an IF frequency to the HP 8902A of greater than 40 MHz when mixed with the RF signal.
- c. Set the RF signal to a level greater than -10 dBm.

- d. Allow the HP 8902A to tune to the signal. (Wait for a frequency display.)
- e. Select 32.9 SPCL. (This is the same as entering 4.4 SPCL, 8.1 SPCL, Log units, Track Mode and 27.3 SPCL.) The light in the TRACK MODE key should be on at this point.
- f. Press the MHz key to enter the manual tune mode.
- g. Select Tuned RF Level (yellow shift key, RF Power key).
- h. If using an HP 11722A or HP 11792A sensor module, press the CALIBRATE key to make an absolute level measurement or set a relative reference by pressing the blue key and the ZERO key.
- i. Step the signal level down in amplitude and press the CALIBRATE key whenever the RECAL annunciator is displayed.

COMMENTS ABOUT SPECIAL FUNCTION 32.9:

If the signal appears to be lost, set the signal level of the device-under-test to greater than -90 dBm. Then select Blue Key, CLEAR (HP-IB code: BC). This key sequence forces a retune of the VCO during Tuned RF Level measurements and should recapture the signal if it has not drifted more than 5 MHz. Once the signal has been recaptured, step the signal down for low-level measurements.

If the signal frequency into the HP 8902A drifts past one of the following frequency boundaries, the Measuring Receiver will lose the signal and the measurement process must be restarted.

40 MHz, 80 MHz, 160 MHz, 320 MHz, and 640 MHz.

33.0 LO Frequency Measurement. Use this special function to display the LO frequency for the signal being measured.

34.0 IF Frequency Measurement. Use this special function to display the IF frequency for the signal being measured. Special Function 3 enables you to manually select the IF for frequencies above 10 MHz. (Refer to *Filters, RF and IF* on page 3-259.)

35.0 RF Level Measurement. Enables the Measuring Receiver to measure the peak RF power. This measurement is selected when RF POWER is selected and no power sensor is connected to the SENSOR input.

36.0. Peak Tuned RF Level Measurement. This measurement is not as accurate or sensitive as the Tuned RF Level Measurement. Use the Peak Tuned RF Level measurement to measure the level of frequencies that are drifting or to determine flatness as a function of carrier frequency.

37. RF Power Calibration Factors. Use this special function to manipulate RF Power calibration factors. An extensive table in *RF Power* on page 3-78 summarizes each of these special functions. Two tables are available with the same special function. The table being used is determined by the status of Frequency Offset Mode (Special Function 27).

- 37.0 Use automatic calibration factors.
- 37.1 Use manual calibration factors.
- 37.2 Display calibration factor status (0=automatic, 1=manual).
- 37.3 Enter calibration factor.
- 37.4 Display table size.
- 37.5 Prepare to recall the reference calibration factor.
- 37.6 Prepare to recall the next frequency/calibration factor pair.
- 37.9 Clear the table.

38. Display Tuned RF Level Calibration Factors. Use this special function to display calibration factors used in Tuned RF Level measurements. This function is useful (when used with Special Function 39) in making repetitive Tuned RF Level measurements at many different frequencies. Measurement time is decreased when it is not necessary to perform calibration. For more details about this function, refer to *Tuned RF Level* on page 3-99. (Note: If the number of test frequencies is less than or equal to eight, consider using the storage registers to save the calibration data. For details about storing measurement settings, refer to *Store/Recall* on page 3-253.)

To display and then re-use Tuned RF Level calibration factors, perform calibration at the frequency of interest, read the calibration factors using Special Function 38, then re-enter the calibration factors before making measurements at the previously measured frequency using Special Function 39.

38.1 Display the calibration factor for Range #1.

38.2 Display the calibration factor for Range #2.

38.3 Display the calibration factor for Range #3.

38.4 ⁶ Display the SET REF reference calibration value. (This cal factor is displayed with a maximum of eight digits and a resolution of 0.01%.)

39. Enter Tuned RF Level Calibration Factors. Use this special function to enter calibration factors used in Tuned RF Level measurements. This function is useful (when used with Special Function 38) in making repetitive Tuned RF Level measurements at many different frequencies. Measurement time is decreased when it is not necessary to perform calibration. For more details about this function, refer to *Tuned RF Level* on page 3-99. (Note: If the number of test frequencies is less than or equal to eight, consider using the storage registers to save the calibration data. For details about storing instrument settings, refer to *Store/Recall* on page 3-253.)

To display and then re-use Tuned RF Level calibration factors, perform calibration at the frequency of interest; read the calibration factors using Special Function 38; then re-enter the calibration factors before making measurements at the previously measured frequency using Special Function 39. (Before using Special Function 39, ensure that the instrument is tuned to the input signal.)

39.1 Enter the calibration factor for Range #1.

39.2 Enter the calibration factor for Range #2.

39.3 Enter the calibration factor for Range #3.

39.4 ⁷ Enter the SET REF reference calibration value.

39.9 Clear all calibration factors.

⁶ This special function is not available with firmware date codes 234.1985 and below. (To display the firmware date code, select 42.0 SPCL.) To order a ROM set that contains this special function, contact the nearest HP sales office.

⁷ This special function is not available with firmware date codes 234.1985 and below. (To display the firmware date code, select 42.0 SPCL.) To order a ROM set that contains this special function, contact the nearest HP sales office.

ERROR MESSAGE SUMMARY

DESCRIPTION

Error Messages are one means the Measuring Receiver uses to safeguard measurement integrity. When the instrument senses a potential error-causing situation, an Error Message code is displayed to alert the user of the condition. The Error Message code indexes an Error Message which describes the current error. Error Messages indicate operating problems, incorrect keyboard entries, or service-related problems. The error message is usually cleared when the error condition is removed.

Two types of error message display formats are used:

Error NN: The numerical value (NN) of the error message is displayed and

-- No detectable signal falls within the IF passband. Either no signal is at the input, or the instrument cannot tune to find the applied signal. (For example, it might be manually tuned far enough away from an input signal that no power is detected in the IF.) This display is output to the HP-IB as Error 96 using the HP-IB output format described in "HP-IB Output Format".

----- A signal has been detected but, for various reasons, a measurement result is not yet available. The instrument might be still completing the measurement requested, or in some cases, unable to complete a measurement because of manual settings of special functions. (For example, when frequency measurements are made on a low-level input signal with high AM depth, or when the RF input attenuation or gain is improperly set.) This display is never output to the HP-IB and typically indicates a transitory state in instrument operation.

----- The IF synchronous detector circuitry is searching for the IF signal. This error message can only be displayed when the IF synchronous detector is used in the Tuned RF Level measurement mode. (Refer to *Tuned RF Level* on page 3-95.) This display is never output to the HP-IB and typically indicates a transitory state in instrument operation.

Error messages are grouped by error code as follows:

Errors 01 through 19 and 90 through 99.

These messages are Operating Errors which indicate a condition has not been met to assure a calibrated measurement. Operating Errors can usually be cleared by readjustment of front-panel controls (usually, the easiest way is to select AUTOMATIC OPERATION). The DISABLE ERROR key or Special Function 8 can be used to selectively disable Errors 01 through 04. (Refer to *Error Message Disable Control* on page 3-267.)

Errors 20 through 29.

These messages are Entry Errors which indicate an invalid key sequence or keyboard entry. These errors require that a new keyboard entry or function selection be made. Some of these error displays time out after a few seconds and then allow the display to return to the current measurement.

Errors 30 through 39.

These messages are Tuned RF Level Calibration Errors which indicate a condition that has not been met to assure calibration. The error can usually be cleared by readjusting the input signal, or by setting Special Functions 1 and 9 to automatic selection.

Errors 40 through 89.

These messages are Service Errors generated to provide service-related information. They must be enabled to be displayed since they are not displayed in normal instrument operation. Service Error Messages are discussed in Section 8 of the Service Manual.

HP-IB

HP-IB Output Format

The HP-IB output format for errors is shown below:

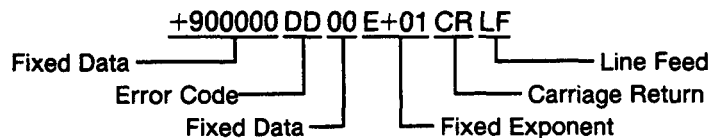

For example, Error 02 is output to the HP-IB as +9000000200E+01CRLF. Once an error has been input to the computing controller, the error code is simply derived by subtracting 9×10^{10} from the input number, then dividing the result by 1000.

Error Messages

The following table describes all Operating Errors and includes the error code, message, and the action typically required to remove the error-causing condition. The COMMENTS column that follows provides additional information and references pertaining to particular error messages.

Operating Errors		
Error Code	Message	Corrective Action
01	IF frequency error.	Retune to signal at input.
02	Input level too high.	Increase RF input attenuation.
03	Input Level too low.	Decrease RF input attenuation.
04	Audio circuits overdriven.	Increase audio range.
05	FM spluclched.	Reduce signal level varations (AM) at RF INPUT.
06	RF input overload.	Reduce RF signal level at RF INPUT, then press any key.
07	Voltmeter and display overload.	Increase audio range.
08	Calibrator error.	Connect CALIBRATION AM/FM OUTPUT to RF INPUT or turn off calibrator.
09	Option not installed.	Select another instrument function.
10	Input frequency out of range.	Adjust input frequency to within specified limits.
11	Calculated value out of range.	Conversion from % to dB is not possible. Press LOG/LIN for linear display.
12	Time Base oven cold (Option 002).	For highest accuracy, wait until oven is warm. (Refer to Special Function 15.)
13	Power sensor not connected.	Press RF POWER. RF level measurement is initiated if the power sensor is not connected.
14	Power sensor cannot zero.	Assure zero power at SENSOR input.
15	Calibration factor error.	Input calibration factors.
16	Audio circuits underdriven.	Increase external audio input level.
17	Selective power measurement (option series 030)	Release RANGE HOLD, adjust input level or re-reference measurement.
18	RF Power will not calibrate.	Assure 0 dBm at SENSOR input.
19	Tuned RF Level circuits underdriven.	Press Automatic Operation.
96	(HP-IB only) No input signal sensed by instrument.	Increase signal level at RF INPUT or retune.

COMMENTS

Error 01

With the 1.5 MHz IF, the IF frequency must be 1.5 MHz ±50 kHz.
 With the 455 kHz IF, the IF frequency must be 455 kHz ±2.5 kHz. (±5 kHz in Tuned RF level.)
 Refer to RF Frequency Tuning. Error 01 disables MODULATION OUTPUT/AUDIO INPUT.

Error 02

Refer to RF Input Attenuation and Gain for nominal input levels. Error 02 disables MODULATION OUTPUT/AUDIO INPUT.

Error 03

Refer to RF Input Attenuation and Gain for nominal input levels. Error 03 disables MODULATION OUTPUT/AUDIO INPUT.

Error 06

Maximum allowable input level is 7 Vrms (1W peak).

Error 07

If displayed during modulation measurements, increase audio range. If displayed during level measurements, increase RF input attenuation or increase RF power range.

Error 08

If the connection from CALIBRATION AM/FM OUTPUT to RF INPUT is intact, this error may indicate calibrator malfunction.

Error 09

Error 09 display times out. If the option is installed, Error 09 displayed may indicate an option malfunction.

Error 10

Error 10 turns off MODULATION OUTPUT/AUDIO INPUT.

Error 11

In dB RATIO, Error 11 is displayed when measurement result is 0 or negative. (The argument of the log function must be greater than 0.)

Error 12

Error 12 is enabled by Special Function 15.

Error 13

Error 13 usually only occurs when the power sensor is disconnected during an RF power measurement.

Error 14

Error 14 will not occur when using a sensor module (such as the HP 11722A) or a power sensor with an RF switch controlled by voltages accessed from the rear panel. (Refer to *Remote Control RF Switch* on page 3-133.)

Error 15

Refer to *RF Power* on page 3-78 for entry and edit information concerning calibration factors.

Error 17

Several conditions can cause this error:

- IF level too high for available range. Either Range Hold was selected or one of the measurement ranges (Special Functions 1 through 10) was user selected. Select AUTOMATIC OPERATION and try the measurement again.
- IF level too low when making a reference measurement. The reference is below 1.25V. Increase the source level to between 1.25V and 2.5V.
- Either a ratio measurement was attempted with an inadequate reference measurement or the reference was not measured before the ratio measurement was attempted. Take a reference measurement with the reference level between 1.25V and 2.5V.

Error 96

Error 96 corresponds to a display of two dashes (- -). Error 96 can occur when no signal is applied or when Error 03 is disabled and the instrument is manually tuned where no signal is found. Error 96 (- -) turns off MODULATION OUTPUT/AUDIO INPUT.

Entry Errors		
Errors	Message	Corrective Action
20	Entered value out of range.	Re-enter new value.
21	Invalid key sequence.	Check for compatibility of functions selected
22	Invalid Special Function prefix.	Re-enter correct Special Function Code.
23	Invalid Special Function suffix.	Re-enter correct Special Function Code.
24	Invalid HP-IB code.	Re-enter correct HP-IB code.
25	Special Functions selected not compatible with selected measurement.	Press AUTOMATIC OPERATION
26	End of RF POWER calibration factor table reached.	Check number of entries.

Error 20

When this error occurs during single-sideband noise measurements, the bandwidth entry was out-of-range. Usually it is unnecessary to enter a bandwidth for noise measurements. This bandwidth is established at the factory.

Error 24

Error 24 always causes the issuance of a Require Service message on the HP-IB.

Entry Errors		
Errors	Message	Corrective Action
30	Manual input attenuation or gain selection.	Change RF input attenuation and gain.
31	Requires new power reference.	Calibrate RF Power before attempting calibration of Tuned RF Level.
32	Calibration not possible.	Move input Signal level into a valid calibration range.
33	Power sensor reference error.	Maintain consistency in frequency and level at SENSOR during calibration.
34	Signal lost during calibration.	Maintain frequency stability at RF INPUT during calibration.
35	Level error during calibration.	Maintain signal stability at RF INPUT during calibration.

Entry Errors		
Errors	Message	Corrective Action
40-89	Service-related errors.	Refer to service section of HP 8902A instrument manual.

Errors 40 through 89

Service errors are normally disabled.

Table of Contents

Introduction	4-1
Equipment Required	4-1
Performance Test Record	4-1
Calibration Cycle	4-1
Abbreviated Performance Testing	4-1
Performance Test 1—AM	4-2
Performance Test 2—FM	4-8
Performance Test 3— Φ M	4-14
Performance Test 4—Audio Filters	4-18
Performance Test 5—Audio Measurements	4-20
Performance Test 6—Power Reference (Using Reference Comparison)	4-25
Performance Test 7—Power Reference (Using DC Substitution)	4-26
Performance Test 8—Power Meter	4-29
Performance Test 9—SWR	4-31
Performance Test 10—Tuned RF Level (Using a Step Attenuator)	4-35
Performance Test 11—Tuned RF Level (Using a Piston Attenuator)	4-39
Performance Test 12—High-Selectivity Filters (Options 032 and 033)	4-43
Performance Test 13—High-Selectivity Gain (Option Series 030)	4-48
Performance Test 14—Tuned RF Level	4-50
Table 4-1. Performance Test Record	4-51

Section 4

PERFORMANCE TESTS

4-1. INTRODUCTION

The procedures in this section test the instrument's electrical performance using the specifications of Table 1-1 as performance standards. All tests are performed without accessing the interior of the instrument. A simpler operational test is available in Section 3, *Operation*, under the title *Basic Functional Checks*.

NOTE

Unless otherwise noted, no warm-up period is required for the following tests.
Line voltage must be within +5% and -10% of nominal if the results of the performance tests are to be considered valid.

4-2. EQUIPMENT REQUIRED

Equipment required for the performance tests is listed in Table 1-3, *Recommended Test Equipment*. Any equipment that satisfies the critical specifications provided in the table may be substituted for the recommended model(s).

4-3. PERFORMANCE TEST RECORD

Results of the performance tests may be tabulated on the *Performance Test Record* at the end of the procedures. The *Performance Test Record* lists all of the tested specifications and their acceptable limits. The results, recorded at incoming inspection, can be used for comparison in periodic maintenance and troubleshooting and after repairs or adjustments.

4-4. CALIBRATION CYCLE

This instrument requires periodic verification of performance. Depending on the use and environmental conditions, the instrument should be checked using the following performance tests at least once every year.

4-5. ABBREVIATED PERFORMANCE TESTING

No abbreviation of performance testing is recommended.

Performance Test 1—AM

Specification

Characteristic	Performance Limits	Conditions
AMPLITUDE MODULATION		
Rates	20 Hz to 10 kHz 20 Hz to 100 kHz	150 kHz to 10 MHz carrier 10 to 1300 MHz carrier
Depth	To 99%	
Accuracy ^(1,2,3,4)	±2% of reading ±1 digit ±3% of reading ±1 digit ±1% of reading ±1 digit ±3% of reading ±1 digit	150 kHz to 10 MHz carrier; 50 Hz to 10 kHz rates; 5 to 99% depth 150 kHz to 10 MHz carrier; 20 Hz to 10 kHz rates; to 99% depth 10 to 1300 MHz carrier; 50 Hz to 50 kHz rates; 5 to 99% depth 10 to 1300 MHz carrier; 20 Hz to 100 kHz rates; 5 to 99% depth
Flatness ^(5,6)	±0.3% of reading ±1 digit	10 to 1300 MHz carrier; 90 Hz to 10 kHz rates; 20 to 80% depth
Demodulated Output Distortion	<0.3% THD <0.6% THD	<50% depth <95% depth
Residual AM	<0.01% rms	50 Hz to 3 kHz bandwidth
FREQUENCY MODULATION		
AM Rejection ⁽²⁾	<20 Hz peak deviation	50% AM depth; 400 Hz and 1 kHz rates; 50 Hz to 3 kHz bandwidth
PHASE MODULATION		
AM Rejection ⁽²⁾	<0.03 rad peak deviation	50% AM depth; 1 kHz rate; 50 Hz to 3 kHz bandwidth
<p>(1) But not to exceed 50 kHz rates with rms detector.</p> <p>(2) Peak residuals must be accounted for in peak readings. (Refer to <i>Residual Noise Effects</i> in <i>Detailed Operating Instructions</i> in Section 3.)</p> <p>(3) For peak measurements only, AM accuracy may be affected by distortion generated by the Measuring Receiver. In the worst case, this can decrease accuracy by 0.1% of reading for each 0.1% of distortion.</p> <p>(4) For rms detector, add ±3% of reading.</p> <p>(5) Flatness is the variation in indicated AM depth for constant depth on input signal.</p> <p>(6) For optimum flatness, cables should be terminated with their characteristic impedance.</p>		

Description

AM accuracy is measured with the internal AM Calibrator, which produces approximately 33% AM at a 10 kHz rate. A low-residual AM source is connected to the input and the internal residual AM is measured. A source, which can produce wide-band, linear AM, is modulated at various AM rates and depths to measure distortion, flatness, and incidental FM and Φ M. A special AM/FM test source is required for these tests to assure that the AM source has adequate bandwidth, low distortion, low residual AM, and low incidental FM and Φ M.

Equipment

AM/FM Test Source	HP 11715A
Audio Analyzer	HP 8903B
Audio Synthesizer	HP 3336C

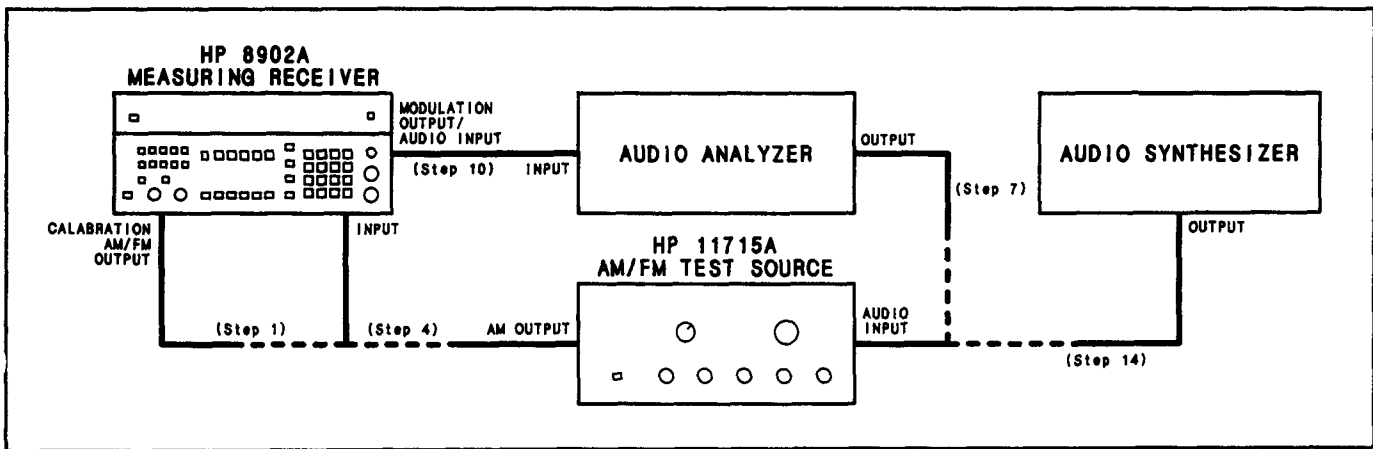

Figure 4-1. AM Performance Test Setup

NOTE

In the following procedure the RF modulation source can be connected either to a sensor module (which is connected to the Measuring Receiver) or directly to the Measuring Receiver's INPUT connector. The procedure is written for the latter case.

Procedure

AM Accuracy at 10 kHz Rate

1. On the Measuring Receiver, press the blue key then press INSTR PRESET (the AUTOMATIC OPERATION key) to preset the instrument. Connect the Measuring Receiver's CALIBRATION AM/FM OUTPUT to its INPUT.

NOTE

For greatest accuracy, allow the Measuring Receiver to warm up for at least one-half hour.

- 2. On the Measuring Receiver, press AM and then press CALIBRATE. Allow at least two readings (approximately 40 seconds) to pass. The display should read between 99 and 101%.

AM Calibration Factor 40% AM Range: 99 _____ 101%

- 3. Key in 2.2 SPCL to set the AM range to 100% AM. Allow at least two readings to pass. The display should read between 99 and 101%. Record this value for future reference.

AM Calibration Factor 100% AM Range: 99 _____ 101%

Residual AM

- 4. On the AM/FM test source, set the test mode switch to AM. Connect the test source AM output to the Measuring Receiver's INPUT. (See Figure 4-1. Nothing should be connected to the test source's audio input.)
- 5. On the Measuring Receiver, press FREQ and TRACK MODE. Tune the AM/FM test source's carrier frequency to approximately 12.5 MHz. Press TRACK MODE again to turn it off.
- 6. On the Measuring Receiver, press AM. Key in 2.0 SPCL to set the modulation range to auto-matic. Set the other controls as follows:

HP FILTER 50 Hz
 LP FILTER 3 kHz
 DETECTOR AVG

The display should show 0.01% or less.

Residual AM: _____ 0.01%

AM Distortion

- 7. Set the audio analyzer's oscillator to 20 kHz. Connect its output to the audio input of the AM/FM test source. (See Figure 4-1.)

NOTE

For this test, if the audio analyzer has floating input and output connectors, the low connector should be grounded. Connections should be made to the high input or high output connector.

- 8. Set the Measuring Receiver controls as follows:

HP FILTER ALL OFF
 LP FILTER ALL OFF
 DETECTOR PEAK+

- 9. Adjust the audio analyzer's oscillator level for a Measuring Receiver display of 50% AM.

10. Connect the audio analyzer's input to the Measuring Receiver's MODULATION OUTPUT/AUDIO INPUT. (See Figure 4-1.) Set the audio analyzer to measure the distortion on the 20 kHz signal at the MODULATION OUTPUT/AUDIO INPUT with 80 kHz of low-pass filtering (on the audio analyzer). The distortion should be 0.3% or less (-50 dB or less).

AM Distortion at 20 kHz Rate; 50% AM: _____ 0.3%

11. Increase the audio analyzer's oscillator level until the Measuring Receiver reads 95% AM. Measure the distortion. The distortion should be 0.6% or less (-44 dB or less).

AM Distortion at 20 kHz Rate; 95% AM: _____ 0.6%

12. Set the audio analyzer's oscillator frequency to 20 Hz. Readjust the level, if necessary, for a Measuring Receiver display of 95% AM. Measure the distortion. The distortion should be 0.6% or less.

AM Distortion at 20 Hz Rate; 95% AM: _____ 0.6%

13. Decrease the audio analyzer's oscillator level until the Measuring Receiver reads 50% AM. Measure the distortion. The distortion should be 0.3% or less.

AM Distortion at 20 Hz Rate; 50% AM: _____ 0.3%

AM Flatness

14. Set the audio synthesizer to 1 kHz at +1 dBm. Connect its output to the audio input of the AM/FM test source. (See Figure 4-1.) Fine adjust the audio synthesizer level for a Measuring Receiver display of 80% AM.

NOTE

Flatness of the audio synthesizer is critical for this test. If the audio synthesizer has leveling capability, switch it on.

15. On the Measuring Receiver, press AVG. Set RATIO on (with LOG/LIN set for a linear display). Set the audio synthesizer frequency as listed in the following table. For each setting, note the Measuring Receiver's display. The difference in readings between any two frequencies should be less than 0.8% REL.

NOTE

±0.3% of reading is equivalent to a difference of 0.6% between any pair of readings. ±1 digit at a nominal reading of 80.0 is about ±0.1% of the reading in the RATIO mode or ±0.2% for any pair of readings. The total limit is then 0.8%.

Audio Synthesizer Frequency (Hz)	Displayed AM (% REL)
1 000	_____
10 000	_____
150	_____
90	_____

AM Flatness (Maximum Difference): _____ 0.8% REL

AM Accuracy

16. On the Measuring Receiver, press **RATIO** to turn it off. Press **PEAK+**. Key in 5.1 SPCL to set the audio detector time constant to slow.
17. Set the audio synthesizer frequency to 10 kHz. Set the audio synthesizer level for a display as close as possible to 80.0% on the Measuring Receiver. Record the display reading below.

≈80.0% reading: _____ % AM

18. On the Measuring Receiver, key in the reading recorded in step 17 divided by the AM calibration factor recorded in step 3 then press **RATIO**. For example, if the AM Calibration Factor from step 3 is 100.4% and the reading from step 17 is 80.15%, you would key in 79.83 (that is, $80.15/1.004$), then press the **RATIO** key.

Audio Synthesizer Frequency (Hz)	AM Limits (% REL)		
	Lower	Actual	Upper
50 000	98.9	_____	101.1
100 000	96.9	_____	103.1
50	98.9	_____	101.1
20	96.9	_____	103.1

NOTE

±1 digit at a nominal reading of 80.0 is about ±0.1% of the reading in the RATIO mode.

19. On the Measuring Receiver, key in 3.1 SPCL to set the IF to 455 kHz. Set the audio synthesizer to the frequencies in the following table. For each setting, the Measuring Receiver's display should read between the limits indicated in the table.

Audio Synthesizer Frequency (Hz)	AM Limits (% REL)		
	Lower	Actual	Upper
20	96.9	_____	103.1
50	97.9	_____	102.1
10 000	97.9	_____	102.1

AM Rejection

20. On the Measuring Receiver, press **RATIO** to turn it off. Set the **HP FILTER** to 50 Hz and the **LP FILTER** to 3 kHz.
21. Set the audio synthesizer frequency to 1 kHz. Set its level for a Measuring Receiver display of 50% AM.
22. On the Measuring Receiver, press **FM**. Momentarily disconnect the audio input to the AM/FM test source and note the residual FM displayed on the Measuring Receiver.

Residual FM; 455 kHz IF: _____ Hz

23. Reconnect the audio input of the AM/FM test source. Note the Measuring Receiver's displayed FM. The displayed FM minus one-half the residual FM noted in step 22 should be 20 Hz peak or less.

AM Rejection (with FM); 455 kHz IF: _____ 20 Hz

24. On the Measuring Receiver, key in 3.0 SPCL to set the IF back to 1.5 MHz. Repeat steps 22 and 23.

Residual FM; 1.5 MHz IF: _____ Hz
AM Rejection (with FM); 1.5 MHz IF: _____ 20 Hz

25. On the Measuring Receiver, press Φ M. Momentarily disconnect the audio input to the AM/FM test source and note the residual Φ M displayed on the Measuring Receiver.

Residual Φ M; 1.5 MHz IF: _____ rad

26. Reconnect the audio input of the AM/FM test source. Note the Measuring Receiver's displayed Φ M. The displayed Φ M minus one-half the residual Φ M noted in step 25 should be 0.030 rad peak or less.

AM Rejection (with Φ M); 1.5 MHz IF: _____ 0.030 rad

Performance Test 2—FM

Specification

Characteristic	Performance Limits	Conditions
FREQUENCY MODULATION		
Rates ⁽⁵⁾	20 Hz to 10 kHz 20 Hz to 200 kHz 20 Hz to 20 kHz	150 kHz to 10 MHz carrier 10 to 1300 MHz carrier 10 to 1300 MHz carrier; 750 μ s de-emphasis
Deviations ⁽⁵⁾	40 kHz peak maximum 400 kHz peak maximum 40 kHz peak maximum	150 Hz to 10 MHz carrier 10 to 1300 MHz carrier 10 to 1300 MHz carrier; 750 μ s de-emphasis
Accuracy ^(1,2,3,5)	$\pm 2\%$ of reading ± 1 digit	250 kHz to 10 MHz carrier; 20 Hz to 10 kHz rates; <40 kHz peak deviation
	$\pm 1\%$ of reading ± 1 digit	10 to 1300 MHz carrier; 50 Hz to 100 kHz rates; <400 kHz peak deviation; <40 kHz peak deviation with 750 μ s de-emphasis
	$\pm 5\%$ of reading ± 1 digit	10 to 1300 MHz carrier; 20 Hz to 200 kHz rates; <400 kHz deviation; <40 kHz peak deviation with 750 μ s de-emphasis
Demodulated Output Distortion ^(4,5)	<0.1% THD	400 kHz to 10 MHz carrier; 20 Hz to 10 kHz rates; <10 kHz peak deviation
	<0.1% THD	10 to 1300 MHz carrier; 20 Hz to 100 kHz rates; <100 kHz peak deviation; <40 kHz peak deviation with 750 μ s de-emphasis
Residual FM	<8 Hz rms at 1300 MHz decreasing linearly with frequency to <1 Hz rms for 100 MHz and below	50 Hz to 3 kHz bandwidth
<p>(1) But not to exceed 50 kHz rates with rms detector.</p> <p>(2) Peak residuals must be accounted for in peak readings. (Refer to <i>Residual Noise Effects in Detailed Operating Instructions</i> in Section 3.)</p> <p>(3) For rms detector, add $\pm 3\%$ of reading.</p> <p>(4) With 750 μs de-emphasis and pre-display "off", distortion is not specified for modulation outputs >4V peak. This can occur near maximum deviation for a measurement range at rates <2 kHz.</p> <p>(5) But not to exceed 20 kHz rates and 40 kHz peak deviation with 750 μs de-emphasis.</p>		

Characteristic	Performance Limits	Conditions
AMPLITUDE MODULATION		
FM Rejection ⁽²⁾	<0.2% AM	250 kHz to 10 MHz carrier; <5 kHz peak deviation; 400 and 1000 Hz rates; 50 Hz to 3 kHz bandwidth
	<0.2% AM	10 to 1300 MHz carrier; <50 kHz peak deviation; 400 Hz and 1 kHz rates; 50 Hz to 3 kHz bandwidth
(2) Peak residuals must be accounted for in peak readings. (Refer to <i>Residual Noise Effects</i> in <i>Detailed Operating Instructions</i> in Section 3.)		

Description

FM is measured with a very low-noise oscillator at the Measuring Receiver's input. The resulting measured FM is the residual FM of the Measuring Receiver's internal local oscillator. FM accuracy is measured with the internal FM Calibrator, which produces approximately 34 kHz peak deviation at a 10 kHz rate. A source, which can produce wide-band, linear FM, is modulated at various FM rates and deviations to measure distortion, flatness, and incidental AM. A special AM/FM test source is required for these tests to assure that the FM source has adequate bandwidth, low distortion, low residual FM, and low incidental AM.

Equipment

- AM/FM Test Source HP 11715A
- Audio Analyzer HP 8903B
- Audio Synthesizer HP 3336C

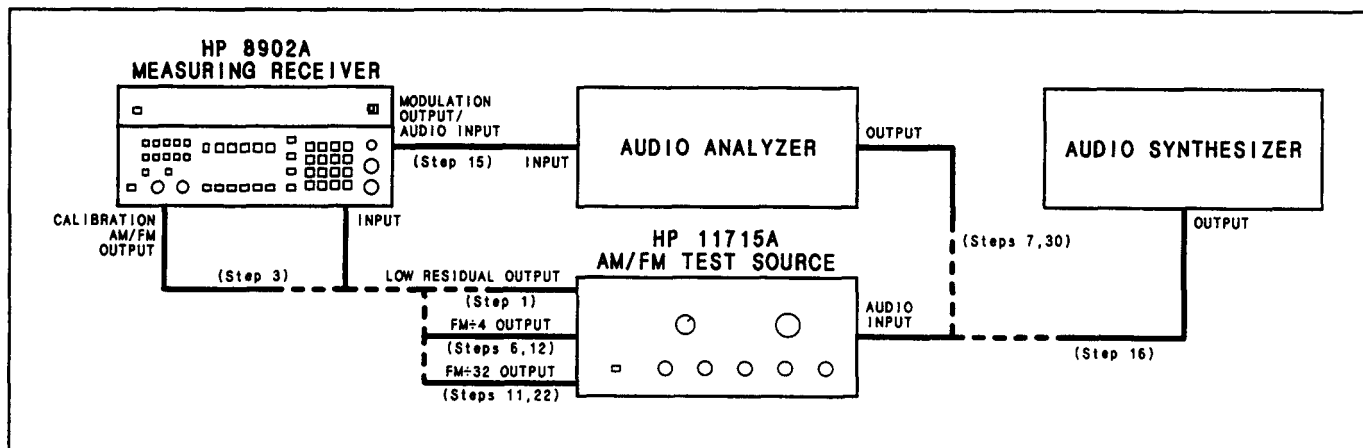

Figure 4-2. FM Performance Test Setup

NOTE

In the following procedure the RF modulation source can be connected either to a sensor module (which is connected to the Measuring Receiver) or directly to the Measuring Receiver's INPUT connector. The procedure is written for the latter case.

Procedure

Residual FM

1. On the AM/FM test source, set the test mode to residual FM. Connect its low-residual (560 MHz) output to the Measuring Receiver's INPUT. (See Figure 4-2.)
2. On the Measuring Receiver, press the blue key then press INSTR PRESET (the AUTOMATIC OPERATION key) to preset the instrument. Set the other controls as follows:

MEASUREMENT FM
 HP FILTER 50 Hz
 LP FILTER 3 kHz
 DETECTOR AVG

The display should read 4 Hz or less.

Residual FM at 560 MHz; 50 Hz to 3 kHz bandwidth: _____ 4 Hz

NOTE

The equation for determining the residual FM limits is:

$$\text{residual FM in Hz} = 5.83 \times \text{carrier frequency in GHz} + 0.42 \text{ Hz.}$$

For a carrier of 560 MHz, the residual FM limit is 3.7 Hz. Allowing for one digit of uncertainty gives a limit of approximately 4 Hz.

FM Accuracy at 10 kHz Rate

3. Connect the Measuring Receiver's CALIBRATE AM/FM OUTPUT to the INPUT. (See Figure 4-2.)

NOTE

For greatest accuracy, allow the Measuring Receiver to warm up for at least one-half hour.

4. On the Measuring Receiver, press CALIBRATE. Allow at least two readings (approximately 40 seconds) to pass. The display should read between 99 and 101%. Record this value for future reference.

FM Calibration Factor; 40 kHz Modulation Range: 99 _____ 101%

5. On the Measuring Receiver, key in 2.3 SPCL to set the modulation range to 400 kHz. Allow at least two readings to pass. The display should read between 99 and 101%.

FM Calibration Factor; 400 kHz Modulation Range: 99 _____ 101%

6. On the AM/FM test source, set the test mode to FM. Connect its FM÷4 output to the Measuring Receiver's INPUT. (See Figure 4-2.)
7. Set the audio analyzer's oscillator to 10 kHz at 1V. Connect its output to the audio input of the AM/FM test source. (See Figure 4-2.)

NOTE

For this test, if the audio analyzer has floating input and output connectors, the low connector should be grounded. Connections should be made to the high input or high output connector.

8. On the Measuring Receiver, press **FREQ** and **TRACK MODE**. Tune the AM/FM test source's carrier frequency to approximately 100 MHz. Press **TRACK MODE** again to turn it off.
9. On the Measuring Receiver, press **FM**. Set **LP FILTER** to 15 kHz and **DETECTOR** to **AVG**. Key in 2.0 SPCL to set the modulation range to automatic.
10. Adjust the audio analyzer's oscillator level for a Measuring Receiver display of 20 kHz average deviation. On the Measuring Receiver, set **RATIO** on (with **LOG/LIN** set for a linear display).
11. Connect the FM÷32 output of the AM/FM test source to the Measuring Receiver's INPUT without disturbing the AM/FM test source's controls. (See Figure 4-2.) Multiply the displayed ratio on the Measuring Receiver by the calibration factor of step 4. (For example, if the display reads 12.52% REL and the calibration factor of step 4 is 100.4%, the result is $12.52 \times 100.4 = 12.57\%$ REL.) The result should be between 12.35 and 12.65% REL.

FM Accuracy; 4 kHz Modulation Range: 12.35 _____ 12.65% REL

FM Distortion, Accuracy, and Rejection—1.5 MHz IF

12. Connect the FM÷4 output of the AM/FM test source to the Measuring Receiver's INPUT. (See Figure 4-2.)
13. On the Measuring Receiver, set all **LP FILTERS** to off, **DETECTOR** to **PEAK+**, and **RATIO** off.
14. Set the audio analyzer's oscillator frequency to 100 kHz. Set the level for a Measuring Receiver display of 100 kHz peak deviation.
15. Connect the audio analyzer's input to the Measuring Receiver's **MODULATION OUTPUT/AUDIO INPUT**. (See Figure 4-2.) Set the audio analyzer to measure the distortion on the 100 kHz signal at the **MODULATION OUTPUT/AUDIO INPUT** (all audio analyzer filters should be off). The distortion should be 0.1% or less (-60 dB or less).

FM Distortion at 100 kHz Rate; 100 kHz Peak Deviation: _____ 0.1%

16. Set the audio synthesizer to 10 kHz at +5 dBm. Connect its output to the audio input of the AM/FM test source. (See Figure 4-2.) Fine adjust the level for a Measuring Receiver display of 100 kHz times the calibration factor of step 5. (For example, if the calibration factor of step 5 is 100.4%, set the level for a display of 100.4 kHz.)

NOTE

Flatness of the audio synthesizer is critical for this test. If the audio synthesizer has leveling capability, switch it on.

17. Set the audio synthesizer to the frequencies in the following table. For each setting, the Measuring Receiver's display should read between the limits indicated in the table.

Audio Synthesizer Frequency (Hz)	FM Limits (kHz)		
	Lower	Actual	Upper
50 000	98.9	_____	101.1
100 000	94.9	_____	105.1
50	98.9	_____	101.1
20	94.9	_____	105.1

18. On the Measuring Receiver, set HP FILTER to 50 Hz and LP FILTER to 3 kHz.
19. Set the audio synthesizer frequency to 1 kHz. Set the level for a Measuring Receiver display of 50 kHz peak deviation.
20. On the Measuring Receiver, press AM. Momentarily disconnect the audio input to the AM/FM test source and note the residual AM displayed on the Measuring Receiver.

Residual AM: _____ %

21. Reconnect the audio input of the AM/FM test source. Note the AM displayed on the Measuring Receiver. The displayed AM minus one-half the residual AM noted in step 20 should be 0.2% or less.

FM Rejection at 1 kHz Rate; 50 kHz Peak Deviation: _____ 0.2%

FM Distortion, Accuracy, and Rejection—455 kHz IF

22. Connect the FM÷32 output of the AM/FM test source to the Measuring Receiver's INPUT. (See Figure 4-2.)
23. On the Measuring Receiver, key in 3.1 SPCL to set the IF to 455 kHz. Press FM.
24. Set the audio synthesizer level for a Measuring Receiver display of 5 kHz peak deviation.
25. On the Measuring Receiver, press AM. Momentarily disconnect the audio input to the AM/FM test source and note the residual AM displayed on the Measuring Receiver.

Residual AM: _____ %

26. Reconnect the audio input of the AM/FM test source. Note the AM displayed on the Measuring Receiver. The displayed AM minus one-half the residual AM noted in step 25 should be 0.2% or less.

FM Rejection at 1 kHz Rate; 5 kHz Peak Deviation: _____ 0.2%

27. On the Measuring Receiver, press FM. Set all HP FILTERs to off and LP FILTER to >20 kHz.

28. Set the audio synthesizer level for a Measuring Receiver display of 10 kHz peak deviation times the calibration factor of step 4. (For example, if the calibration factor of step 4 is 100.4%, set the level for a display of 10.04 kHz.)
29. Set the audio synthesizer to the frequencies shown in the following table. For each setting, the Measuring Receiver's display should read between the limits indicated in the table.

Audio Synthesizer Frequency (Hz)	FM Limits (kHz)		
	Lower	Actual	Upper
10 000	9.79	_____	10.21
20	9.79	_____	10.21

30. Set the audio analyzer's oscillator to 10 kHz at 4V. Connect its output to the audio input of the AM/FM test source. (See Figure 4-2.) Fine adjust the oscillator level for a Measuring Receiver display of 10 kHz peak deviation.
31. Set the audio analyzer to measure the distortion on the 10 kHz signal at the MODULATION OUTPUT/AUDIO INPUT of the Measuring Receiver. Set the distortion analyzer's low-pass filter to 30 kHz and the high-pass filter to 400 Hz. The distortion should be less than 0.1% (-60 dB or less).

FM Distortion at 10 kHz; 10 kHz Peak Deviation: _____ 0.1%

Performance Test 3— Φ M

Specification

Characteristic	Performance Limits	Conditions
PHASE MODULATION		
Rates	200 Hz to 10 kHz 200 Hz to 20 kHz	150 kHz to 10 MHz carrier 10 to 1300 MHz carrier
Accuracy ^(1,2)	$\pm 4\%$ of reading ± 1 digit $\pm 3\%$ of reading ± 1 digit	150 kHz to 10 MHz carrier 10 to 1300 MHz carrier
Demodulated Output Distortion	<0.1% THD	

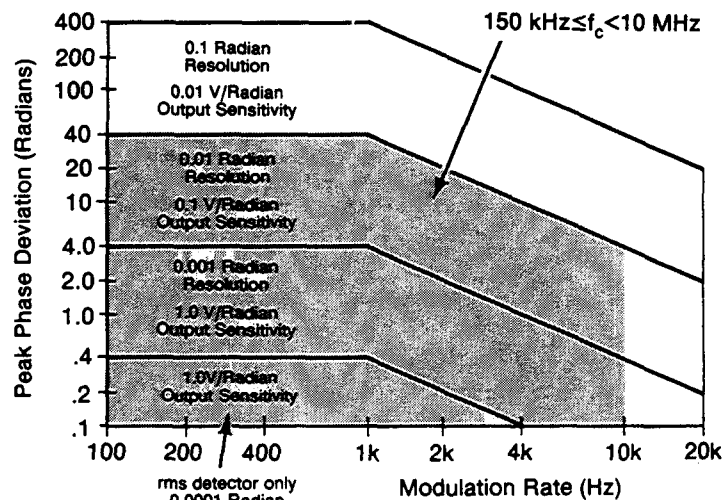

Phase Modulation Deviation and Maximum Resolution

- (1) Peak residuals must be accounted for in peak readings. (Refer to *Residual Noise Effects in Detailed Operating Instructions* in Section 3.)
- (2) For rms detector, add $\pm 3\%$ of reading.

Description

A signal with a known amount of phase modulation is generated by frequency modulating a carrier at a known peak deviation (as measured by the previously-calibrated Measuring Receiver) and rate. The relationship between the peak phase deviation and peak frequency deviation is:

$$\text{peak phase deviation} = \frac{\text{peak frequency deviation}}{\text{modulation rate}}$$

The measured deviation is compared with the calculated deviation for several combinations of FM deviation and rate. The distortion is also measured. A special AM/FM test source is required for these tests to assure that the FM source has adequate bandwidth, low-distortion, and low residual FM.

EQUIPMENT

- AM/FM Test Source HP 11715A
- Audio Analyzer HP 8903B
- Audio Synthesizer..... HP 3336C

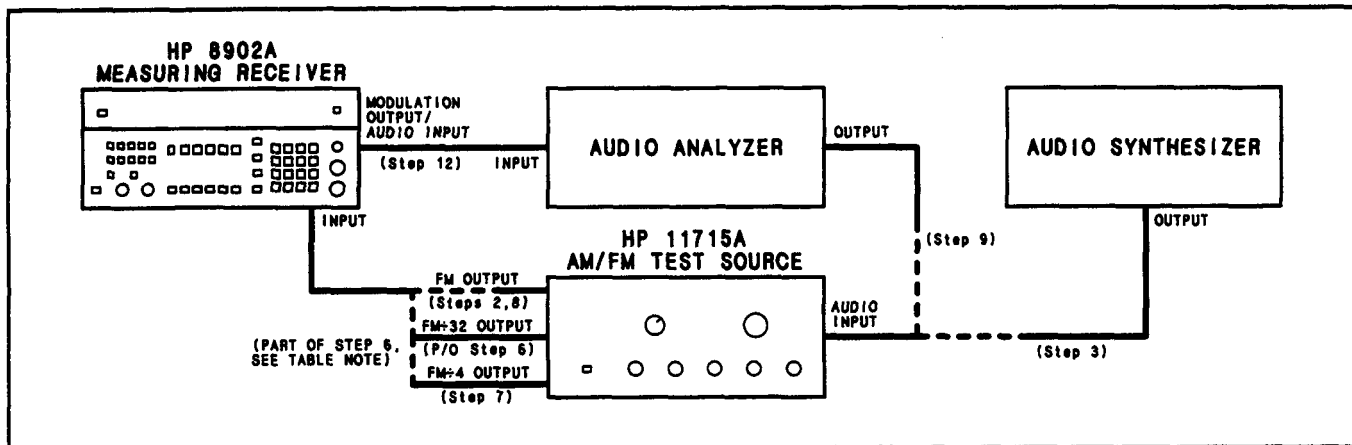

Figure 4-3. FM Performance Test Setup

NOTE

In the following procedure the RF modulation source can be connected either to a sensor module (which is connected to the Measuring Receiver) or directly to the Measuring Receiver's INPUT connector. The procedure is written for the latter case.

PROCEDURE

FM Accuracy

1. Perform *Performance Test 2—FM*.
2. On the AM/FM test source, set the test mode to FM. Connect its FM output to the Measuring Receiver's INPUT. (See Figure 4-3.)
3. Set the audio synthesizer to 200 Hz at -10 dBm. Connect its output to the audio input of the AM/FM test source. (See Figure 4-3.)
4. On the Measuring Receiver, press the blue key then press INSTR PRESET (the AUTOMATIC OPERATION key) to preset the instrument. Press **FREQ** and **TRACK MODE**. Tune the AM/FM test source's carrier frequency to approximately 400 MHz. Press **TRACK MODE** again to turn it off.
5. On the Measuring Receiver, set the controls as follows:

MEASUREMENT	FM
LP FILTER	>20 kHz
DETECTOR	AVG

6. Set the audio synthesizer frequency as shown in the following table. Set the Measuring Receiver High Pass Filter as shown in the table. Set the audio synthesizer level to give the FM deviation shown in the table (as read on the Measuring Receiver). After setting each FM deviation, press Φ M. For each setting, the Measuring Receiver's display should read between the limits indicated in the table.

Audio Synthesizer Frequency (Hz)	High Pass Filter	Average FM Deviation (kHz)	Φ M Limits (rad)		
			Lower	Actual	Upper
200	50	50	242.4	_____	257.6
1 000	200	250	242.4	_____	257.6
20 000	300	250	12.0	_____	13.0
20 000	300	4*	0.193	_____	0.207

* Connect the FM÷32 output of the AM/FM test source to the Measuring Receiver's INPUT to make this measurement. (See Figure 4-3.) Press AUTOMATIC OPERATION, then MHz to return the Measuring Receiver. If the resolution is not 0.001 rad, press Φ M again.

7. On the Measuring Receiver, key in 3.1 SPCL to set the IF to 455 kHz. Press FM. On the AM/FM test source, connect the FM÷4 output. (See Figure 4-3.) Set the audio synthesizer frequency as shown in the following table. Set the Measuring Receiver High Pass Filter as shown in the table. Set the audio synthesizer level to give the FM deviation shown in the table. After setting each FM deviation, press Φ M. For each setting, the Measuring Receiver's display should read between the limits indicated in the table.

Audio Synthesizer Frequency (Hz)	High Pass Filter	Average FM Deviation (kHz)	Φ M Limits (rad)		
			Lower	Actual	Upper
10 000	300	25	2.39	_____	2.61
10 000	300	2.5	0.239	_____	0.261
1 000	300	25	24.0	_____	26.0
200	50	5	24.0	_____	26.0

Φ M Distortion

8. Connect the FM output of the AM/FM test source to the Measuring Receiver's INPUT. (See Figure 4-3.) Press AUTOMATIC OPERATION on the Measuring Receiver.
9. Set the audio analyzer's oscillator to 1 kHz. Connect its output to the audio input of the AM/FM test source. (See Figure 4-3.)

NOTE

For this test, if the audio analyzer has floating input and output connectors, the low connector should be grounded. Connections should be made to the high input or high output connector.

10. On the Measuring Receiver, press Φ M. Set DETECTOR to PEAK+. Set HP FILTER to 300 Hz. Set LP FILTER to 15 kHz.
11. Adjust the audio analyzer's oscillator level to give a display of 400 rad peak deviation.

12. Connect the audio analyzer's input to the Measuring Receiver's MODULATION OUTPUT/AUDIO INPUT. (See Figure 4-3.) Set the audio analyzer to measure the distortion on the 1 kHz signal at the MODULATION OUTPUT/AUDIO INPUT. Set the high-pass filter on the audio analyzer to 400 Hz. The distortion should be 0.1% (-60 dB) or less.

Φ M Distortion at 1 kHz Rate; 400 rad Peak Deviation; 1.5 MHz IF: _____ 0.1%

13. Reduce the audio analyzer's oscillator level to give a display of 40 rad peak deviation.
14. On the Measuring Receiver, key in 3.1 SPCL. The distortion measured on the audio analyzer should be 0.1% or less.

Φ M Distortion at 1 kHz Rate; 40 rad Peak Deviation; 455 kHz IF: _____ 0.1%

Performance Test 4—Audio Filters

Specification

Characteristic	Performance Limits	Conditions
AUDIO FILTERS		
50 Hz High-Pass (2 Pole) 3 dB Cutoff Frequency Flatness	50 Hz nominal <1%	>200 Hz rates
300 Hz High-Pass (2 Pole) 3 dB Cutoff Frequency Flatness	300 Hz nominal <1%	>1 kHz rates
3 kHz Low-Pass (5 Pole) 3 dB Cutoff Frequency Flatness	3 kHz nominal <1%	<1 kHz rates
15 kHz Low-Pass (5 Pole) 3 dB Cutoff Frequency Flatness	15 kHz nominal <1%	<10 kHz rates
>20 kHz Low-Pass (9 Pole Bessel) ⁽¹⁾ Flatness	< 1%	<10 kHz rates
⁽¹⁾ The >20 kHz low-pass filter is intended for minimum overshoot squarewave modulation.		

Description

A signal is frequency modulated by a source which is known to have FM which is flat with rate. The flatness of the demodulated signal is then measured for various modulation filters.

NOTE

Flatness of the audio synthesizer is critical for this test. If the audio synthesizer has leveling capability, switch it on.

Equipment

AM/FM Test Source HP 11715A
 Audio Synthesizer HP 3336C

Procedure

NOTE

In the following procedure the RF modulation source can be connected either to a sensor module (which is connected to the Measuring Receiver) or directly to the Measuring Receiver's INPUT connector. The procedure is written for the latter case.

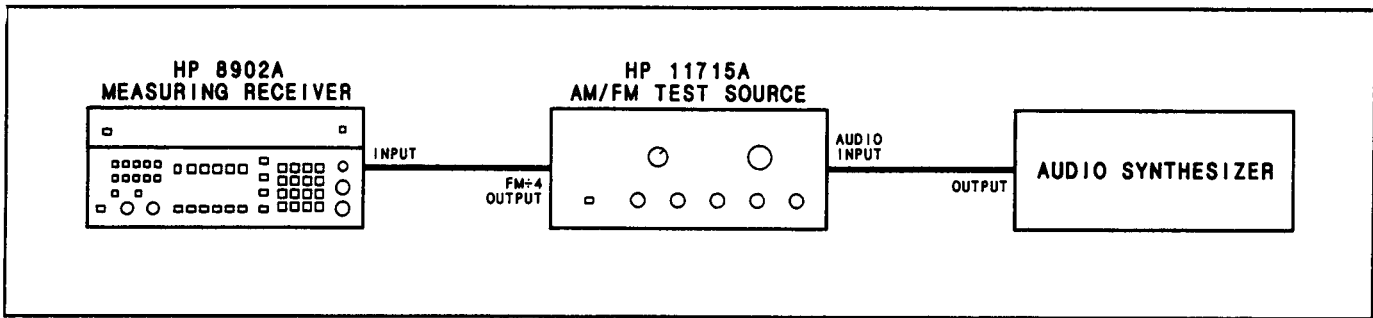

Figure 4-4. Audio Filters Performance Test Setup

1. Connect the equipment as shown in Figure 4-4.
2. On the AM/FM test source, set the test mode to FM.
3. Set the audio synthesizer to 200 Hz at +6 dBm.
4. On the Measuring Receiver, press the blue key then press INSTR PRESET (the AUTOMATIC OPERATION key) to preset the instrument. Press FREQ and TRACK MODE. Tune the AM/FM test source's carrier frequency to approximately 100 MHz. Press TRACK MODE again to turn it off.
5. On the Measuring Receiver, press MHz to center the instrument's tuning. Set the other controls as follows:

MEASUREMENT FM
 DETECTOR AVG

6. Set the audio synthesizer level to give a display of approximately 25 kHz average deviation.
7. Set the audio synthesizer frequency to the frequencies shown in the following table. For each setting, set RATIO on the Measuring Receiver to off, set all HP or LP FILTERs to off, then set RATIO to on (with LOG/LIN set for a linear display), and insert the filter indicated. For each setting, the Measuring Receiver's display should read between the limits indicated in the table.

Audio Synthesizer Frequency (Hz)	Filter	Ratio Limits (% REL)		
		Lower	Actual	Upper
200	50 Hz HP FILTER	98.99	_____	101.01
2 000	50 Hz HP FILTER	98.99	_____	101.01
1 000	300 Hz HP FILTER	98.99	_____	101.01
10 000	300 Hz HP FILTER	98.99	_____	101.01
1 000	3 kHz LP FILTER	98.99	_____	101.01
100	3 kHz LP FILTER	98.99	_____	101.01
10 000	15 kHz LP FILTER	98.99	_____	101.01
1 000	15 kHz LP FILTER	98.99	_____	101.01
10 000	>20 kHz LP FILTER	98.99	_____	101.01
1 000	>20 kHz LP FILTER	98.99	_____	101.01

Performance Test 5—Audio Measurements

Specification

Characteristic	Performance Limits	Conditions
AUDIO FREQUENCY COUNTER		
Frequency Range	20 Hz to 250 kHz	
Accuracy ⁽¹⁾	reference accuracy ±3 digits reference accuracy ±0.02 Hz reference accuracy ±0.2 Hz	>1 kHz rate; >10% AM, >1.5 kHz FM, or >1.5 rad Φ M; >100 mVrms external <1 kHz rate; >10% AM, >1.5 kHz FM, or >1.5 rad Φ M; >100 mVrms external <3 kHz rate; 1.5 to 10% AM, 0.15 to 1.5 kHz FM, or 0.15 to 1.5 rad Φ M; 3 kHz low-pass filter
AUDIO DISTORTION		
Frequency Range	400 or 1000 Hz ±5%	
Residual Noise and Distortion ⁽¹⁾	<0.3% (-50.4 dB)	20 Hz to 50 kHz bandwidth; <40°C
Accuracy	±1 dB of reading	
Sensitivity	1.5% peak AM 150 Hz peak FM 0.6 rad peak Φ M 0.1 to 3 Vrms	modulation modulation modulation external
AUDIO RMS LEVEL		
Frequency Range	50 Hz to 40 kHz	
Voltage Range	0.1 to 3 Vrms	
Accuracy	±4%	
⁽¹⁾ For demodulated signals, the residual noise generated by the Measuring Receiver must be accounted for in distortion measurements (that is, residual AM, FM, or Φ M).		

Description

All audio measurements are made on external audio signals. Level accuracy is measured by comparing the voltage reading on the Measuring Receiver with the output from a more accurately set audio oscillator. Residual distortion and noise is measured by making a distortion measurement on a

low-distortion oscillator. Measurements must be made at several frequencies within the notch filter range to verify proper nulling of the fundamental. Distortion accuracy is measured by summing a low-distortion output from one oscillator with the output of an oscillator which is set to generate a second through fifth harmonic of known magnitude. The audio counter is checked by counting the signal from a audio frequency synthesizer set to both high and low levels.

EQUIPMENT

Audio Analyzer HP 8903B
 Audio Synthesizer..... HP 3336C

PROCEDURE

Audio RMS Accuracy

1. On the Measuring Receiver, press the blue key then press INSTR PRESET (the AUTOMATIC OPERATION key) to preset the instrument. Key in 30.0 SPCL to set the Measuring Receiver to measure external audio rms level.
2. Set the Audio Analyzer output to 50 Hz at 3 V amplitude. (Key in 10.0 SPCL on the HP 8903B to display the output settings.)
3. Connect the Audio Analyzer High Output to the Measuring Receiver's Modulation Output/Audio Input connector. Set the Audio Analyzer Output Float/GND switch to GND.
4. Set the Audio Analyzer to the frequencies shown in the following table. For each setting, the Measuring Receiver's display should read between the limits indicated in the table.

Audio Analyzer Frequency (Hz)	Level Limits (Vrms)		
	Lower	Actual	Upper
50	2.88	_____	3.12
500	2.88	_____	3.12
5 000	2.88	_____	3.12
40 000	2.88	_____	3.12

5. Set the Audio Analyzer level to 100 mV. Set the Audio Analyzer to the frequencies shown in the following table. For each setting, the Measuring Receiver's display should read between the limits indicated in the table.

Audio Analyzer Frequency (Hz)	Level Limits (mVrms)		
	Lower	Actual	Upper
40 000	96	_____	104
5 000	96	_____	104
500	96	_____	104
50	96	_____	104

Audio Counter Range and Sensitivity

6. On the Measuring Receiver, press S (shift) then AUDIO FREQ. Disconnect the Audio Analyzer from the Measuring Receiver's Audio Input. Connect the Audio Synthesizer output to the Measuring Receiver's Audio Input.
7. Set the Audio Analyzer to the frequencies and levels shown in the following table. For each setting, the Measuring Receiver's display should read within the limits indicated in the table.

Audio Synthesizer		Frequency Limits (kHz)		
Frequency (Hz)	Level (dBm)	Lower	Actual	Upper
20	+8	0.01998	_____	0.02002
20	-13.0	0.01998	_____	0.02002
1 000	-13.0	0.99997	_____	1.00003
1 000	+8	0.99997	_____	1.00003
250 000	+8	249.997	_____	250.003
250 000	-13.0	249.997	_____	250.003

Residual Noise and Distortion

8. Set the audio synthesizer to 380 Hz at -13 dBm (100 mV at the audio input).
9. On the Measuring Receiver, press S (shift) then AUDIO DISTN. Press the blue key then press 400 Hz DISTN (the PEAK- key).
10. Slowly step the audio synthesizer up in frequency to 420 Hz using 2 Hz steps or finer. Note the highest distortion reading displayed on the Measuring Receiver. The highest reading should not exceed 0.3%.

Maximum Residual Distortion; 400 Hz Input at 100 mV: _____ 0.3%

11. Increase the audio synthesizer level to +16.5 dBm. Slowly step the audio synthesizer down in frequency to 380 Hz using 2 Hz steps or finer. Note the highest distortion reading displayed on the Measuring Receiver. The highest reading should not exceed 0.3%.

Maximum Residual Distortion; 400 Hz Input at 3V: _____ 0.3%

12. Set the audio synthesizer frequency to 950 Hz.
13. On the Measuring Receiver, press the blue key then press 1 kHz DISTN (the PEAK+ key).
14. Slowly step the audio synthesizer up in frequency to 1050 Hz using 5 Hz steps or finer. Note the highest distortion reading displayed on the Measuring Receiver. The highest reading should not exceed 0.3%.

Maximum Residual Distortion; 1 kHz Input at 3V: _____ 0.3%

15. Decrease the audio synthesizer level to -13 dBm. Slowly step the audio synthesizer down in frequency to 950 Hz using 5 Hz steps or finer. Note the highest distortion reading displayed on the Measuring Receiver. The highest reading should not exceed 0.3%.

Maximum Residual Distortion; 1 kHz Input at 100 mV: _____ 0.3%

Distortion Accuracy

16. On the audio analyzer, set its output float switch to the float position. Set the audio analyzer's oscillator to 1 kHz at 1V.
17. Set the audio synthesizer to 2 kHz at a level as low as possible without switching the instrument off (but less than -50 dBm). Connect the audio analyzer and audio synthesizer as shown in Figure 4-5. Note that the audio synthesizer is connected to the floating low output of the audio analyzer's output. (This has the effect of summing the two outputs.)

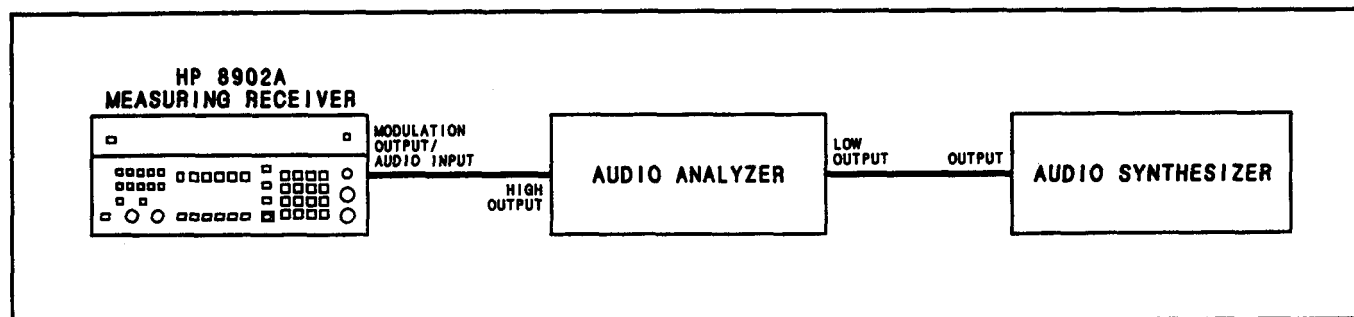

Figure 4-5. Distortion Accuracy Performance Test Setup

18. On the Measuring Receiver, key in 30.0 SPCL to set the Measuring Receiver to measure external audio rms level. (Note that the display reads approximately 1V.) Now set RATIO to on.
19. Set the audio analyzer's oscillator level to 0V or a level as low as possible without switching the instrument off (but at most 10 mV).
20. Increase the audio synthesizer's level until the Measuring Receiver's display reads between 99 and 101%.
21. Switch the audio synthesizer's level down exactly 40 dB. Set the audio analyzer's oscillator level back to 1V.
22. On the Measuring Receiver, press S (shift) then AUDIO DISTN.
23. Set the audio synthesizer's frequency as shown in the following table without changing the audio synthesizer's amplitude. For each setting, the Measuring Receiver's display should read between the limits indicated in the table.

Audio Synthesizer Frequency (kHz)	Distortion Limits (%)		
	Lower	Actual	Upper
2	0.89	_____	1.12
3	0.89	_____	1.12
4	0.89	_____	1.12
5	0.89	_____	1.12

24. Set the audio analyzer's oscillator frequency to 400 Hz without changing its level.
25. On the Measuring Receiver, press the blue key then press 400 Hz DISTN.
26. Set the audio synthesizer's frequency as shown in the following table without changing the audio synthesizer's amplitude. For each setting, the Measuring Receiver's display should read between the limits indicated in the table.

Audio Synthesizer Frequency (Hz)	Distortion Limits (%)		
	Lower	Actual	Upper
800	0.89	_____	1.12
1200	0.89	_____	1.12
1600	0.89	_____	1.12
2000	0.89	_____	1.12

Performance Test 6—Power Reference (Using Reference Comparison)

Specification

Characteristic	Performance Limits	Conditions
POWER REFERENCE		
Power Output	1 mW	
Power Output Accuracy	±1.2%	worst case; for 1 year; 0 to 55°C

Description

The power from an external 1 mW power reference is measured with a power sensor and the power meter of the Measuring Receiver. The same power meter and sensor are then used to measure the power from the Measuring Receiver's power reference.

NOTE

Due to accuracy limitations of this test method, the power level can only be verified to within ±1.9%. Greater accuracy can be obtained by using a recently calibrated external power reference or by following the procedure in Performance Test 7—Power Reference Accuracy (Using DC Substitution).

Equipment

Power Reference HP 435A Opt K05
 Sensor Module HP 11722A

Procedure

1. Connect the input of the sensor module (or a compatible power sensor connected to the Measuring Receiver's SENSOR input) to the output of the external power reference.
2. On the Measuring Receiver, press RF POWER. Press RATIO and check that LOG/LIN is in the linear mode. (The display should read between 99.9 and 100.1% REL.)
3. Connect the power sensor/input switch to the CALIBRATION RF POWER OUTPUT connector of the Measuring Receiver. The display should read 98.1 and 101.9% REL.

RF Power Reference Accuracy: 98.1 _____ 101.9% REL

Performance Test 7—Power Reference (Using DC Substitution)

SPECIFICATION

Characteristic	Performance Limits	Conditions
POWER REFERENCE		
Power Output	1 mW	worst case; for 1 year; 0 to 55°C
Power Output Accuracy	±1.2%	

DESCRIPTION

The power from the power reference oscillator is measured by a method known as dc substitution. In this method a power-sensing thermistor is placed in one arm of a self-balancing, dc resistance bridge. With no power applied, the dc voltage supplying the top of the bridge is automatically adjusted until the thermistor heats to the temperature that produces the resistance required to bring the bridge into balance. When RF power is applied to the thermistor, the thermistor heats up and momentarily unbalances the bridge. The self-balancing circuits then readjust the supply voltage to the bridge to re-balance it. A second bridge, which senses only the ambient temperature, is employed to compensate for measurement drift. Careful measurement of the bridge dc voltages provides a way to determine the amount of RF power applied to the thermistor to a higher degree of accuracy than can be obtained by direct reading of the power meter.

NOTE

The power level can be measured to an accuracy of ±1.2% by this procedure. A simpler, but less accurate method for measuring the power reference can be found in the preceding Performance Test 6—Power Reference (Using Reference Comparison).

EQUIPMENT

Digital Voltmeter HP 3455A
 Power Meter HP 432A
 Thermistor Mount HP 478A Opt H75 *

NOTE

** Must be calibrated at the National Bureau of Standards (NBS) to obtain the accuracy for this test. See Table 1-2 for critical specifications.*

PROCEDURE

1. With the HP 432A Power Meter switched off and the thermistor interconnect cable connected to it but not to the thermistor mount, measure the resistance between the center conductor of the rear-panel VRF connector and pin 1 (the first pin to the right of the key slot) on the thermistor end of the interconnect cable. Record the value of the mount resistance for future reference. (It should be approximately 200Ω.)

Mount Resistance (R): _____ Ω

2. Connect the equipment as shown in Figure 4-6. The input of the digital voltmeter should be floating. The positive input of the voltmeter should be connected to the rear-panel VCOMP connector of the HP 432A Power Meter, the negative input to the VRF connector. Switch the equipment on and let it warm up for at least 30 minutes.

NOTE

From this point on do not handle the HP 478A in order to maintain its thermal stability.

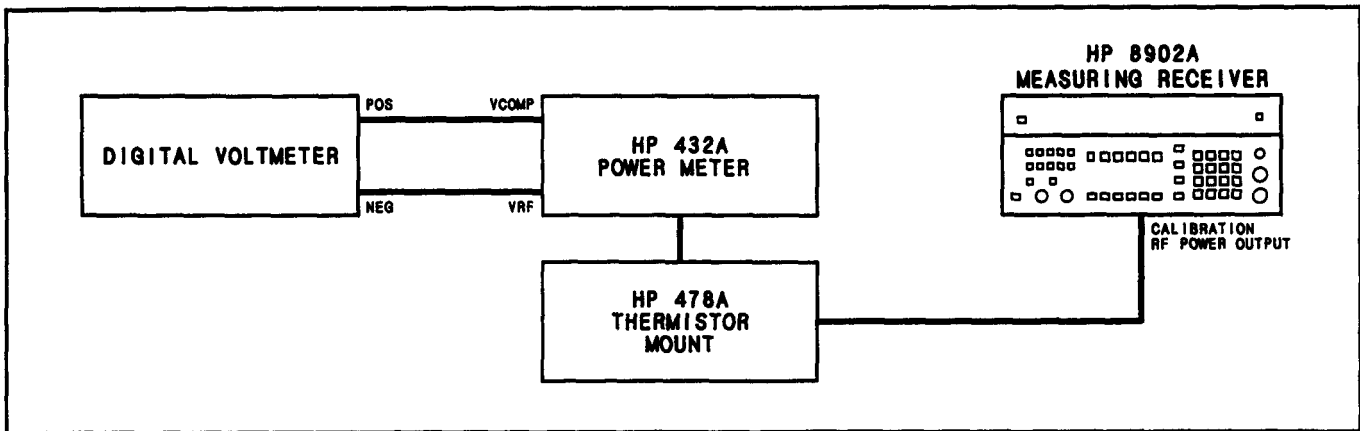

Figure 4-6. Power Reference Performance Test Setup

3. On the Measuring Receiver, key in 45.0 SPCL to switch the power reference off.
4. Set the HP 432A Power Meter RANGE to COARSE ZERO and adjust the front-panel COARSE ZERO to obtain a zero meter indication.
5. Fine zero the HP 432A Power Meter on the most sensitive range, then set the RANGE switch to 1 mW (0 dBm).
6. Observe the voltage reading on the voltmeter. If the reading is greater than 400 μV, press and hold the FINE ZERO switch on the HP 432A Power Meter and adjust COARSE ZERO so that the voltmeter reads less than 200 μV then release the FINE ZERO switch. Record the voltmeter reading for future reference.

$V_{COMP} - V_{RF}$ with No Power (V_0): _____ Vdc

NOTE

Steps 6, 7, and 8 should be performed as quickly as possible to minimize drift.

7. On the Measuring Receiver, key in 45.16 SPCL. Record the voltmeter reading.

$V_{COMP} - V_{RF}$ with 1 mW (V_1): _____ Vdc

8. Connect the voltmeter to read V_{COMP} (with respect to chassis ground) on the HP 432A Power Meter. (The voltmeter's negative input should connect to chassis ground.) Record the voltmeter reading.

V_{COMP} with 1 mW: _____ Vdc

9. Compute the power (P in watts) from the equation

$$P = \frac{2V_{COMP}(V_1 - V_0) + V_0^2 - V_1^2}{4RH}$$

where H is the effective efficiency of the thermistor mount at 50 MHz as read from its label and R is the resistance measured in step 1. The computed power should be between 0.988 and 1.012 mW.

RF Power Reference Power: 0.988 _____ 1.012 mW

Performance Test 8—Power Meter

SPECIFICATION

Characteristic	Performance Limits	Conditions
RF POWER		
RF Range Linearity ⁽¹⁾	±0.02 dB ±0.03 dB	RF ranges 2 to 5 RF range 1
RF Range-to-Range Change Error ⁽¹⁾	±0.02 dB/RF range change from reference range	
Zero Set ⁽²⁾	±0.5% of full scale ±1 count	on lowest range
⁽¹⁾ Using Recorder Output. Using front-panel display, add ±1 count of least-significant digit. ⁽²⁾ Decrease by a factor of ten for each higher range.		

DESCRIPTION

A power meter range calibrator is used to check the range-to-range error, in-range linearity, and zeroing integrity of the power meter circuits. RF power ranging is simulated by a precision voltage divider in the range calibrator.

EQUIPMENT

Range Calibrator..... HP 11683A

PROCEDURE

Zero Set

1. Connect the power meter output of the range calibrator to the Measuring Receiver's SENSOR input.
2. On the range calibrator, set the function to standby, polarity to normal, and range to 1 mW.
3. On the Measuring Receiver, press the blue key then press INSTR PRESET (the AUTOMATIC OPERATION key) to preset the instrument. Press RF POWER. Press ZERO and wait for the instrument to zero.

NOTE

If Error 15 is displayed, press 100 then the blue key then the % CAL FACTOR key (the MHz key) to enter a dummy calibration factor of 100%.

4. On the Measuring Receiver, key in the special functions indicated in the following table. For each setting the Measuring Receiver's display should read as indicated in the table. (Take the average of several readings. Ignore the RECAL and UNCAL annunciators.)

Serial Prefix 2305A to 2449A

Special Function	Power Reading	
	Actual	Maximum
10.1	_____	0.00 μ W \pm 0.06
10.2	_____	0.0 μ W \pm 0.1
10.3	_____	0.000 mW \pm 1 count
10.4	_____	0.00 mW \pm 1 count
10.5	_____	0.0 mW \pm 1 count

Serial Prefix 2451A and above:

Special Function	Power Reading	
	Actual	Maximum
10.1	_____	0.000 μ W \pm 0.051
10.2	_____	0.00 μ W \pm 0.06
10.3	_____	0.0 μ W \pm 0.2
10.4	_____	0.000 mW \pm 1 count
10.5	_____	0.00 mW \pm 1 count

Range-to-Range Error

- On the range calibrator, set the function to calibrate.
- On the Measuring Receiver, key in 10.0 SPCL to set the power meter ranging to automatic. Press CALIBRATE then press the blue key then press SAVE CAL (again, the CALIBRATE key). This normalizes the power reading to 1 mW. (The CALIBRATE key light should be on.)
- On the Measuring Receiver, key in the Special Functions listed in the following table. For each setting, set the range calibrator to the range indicated in the table. The reading on the Measuring Receiver should be within the limits shown.

Special Function	Range Calibrator Range	Power Reading Limits		
		Lower	Actual	Upper
10.1	10 μ W	9.90 μ W	_____	10.10 μ W
10.2	100 μ W	99.4 μ W	_____	100.6 μ W
10.4	10 mW	9.94 mW	_____	10.06 mW
10.5	100 mW	99.0 mW	_____	101.0 mW

Accuracy within a Range

- Set the range calibrator's range to 1 mW.
- On the Measuring Receiver, key in 10.3 SPCL. Set the range calibrator's range to 100 μ W. The Measuring Receiver's display should read between 0.099 and 0.101 mW (0.100 mW \pm 0.5% \pm 1 digit, then rounded to the nearest 0.001 mW).

Accuracy within a Range: 0.099 _____ 0.101 mW

Performance Test 9—SWR

Specification

Characteristic	Performance Limits	Conditions
RF POWER Input SWR	<1.15	using HP 11722A Sensor Module
TUNED RF LEVEL Input SWR	<1.18 <1.40 <1.33 <1.50 <1.33	at RF input; RF range 1 and 2 at RF input; RF range 3 at HP 11722A input; RF range 1 and 2 at HP 11722A input; RF range 3 at HP 11722A input; RF range 3 with Special Function 1.9 (10 dB RF and RF amplifier inserted)

Description

Input SWR is determined by measuring return loss. Measurements are made directly at the Measuring Receiver's input connector and (if available) at the input of a power sensor or sensor module connected to the Measuring Receiver. In either case, the input under test is driven by a signal generator through an SWR bridge. The reflected power is measured by a spectrum analyzer. A reference line is first established by disconnecting the output of the SWR bridge to create a high-reflection, open circuit. Since SWR for the tuned RF level measurement mode is specified only for input levels below 0 dBm, a spectrum analyzer is required to detect the much lower level of the reflected signal.

Equipment

Attenuator, 6 dB	HP 8491A Option 006
RF Spectrum Analyzer	HP 8559A/182T
Sensor Module	HP 11722A
Signal Generator	HP 8640B Option 002
SWR Bridge	Wiltron 60NF50

NOTE

The log display accuracy of the spectrum analyzer may be inadequate for this test. If any data points in the following procedure appear to be near or out of limits, check the amplitude calibration of the spectrum analyzer as described in its manual and use the data obtained there to correct the results in this procedure.

If a tracking generator that is compatible with the RF spectrum analyzer is substituted for the signal generator, a swept measurement can be made.

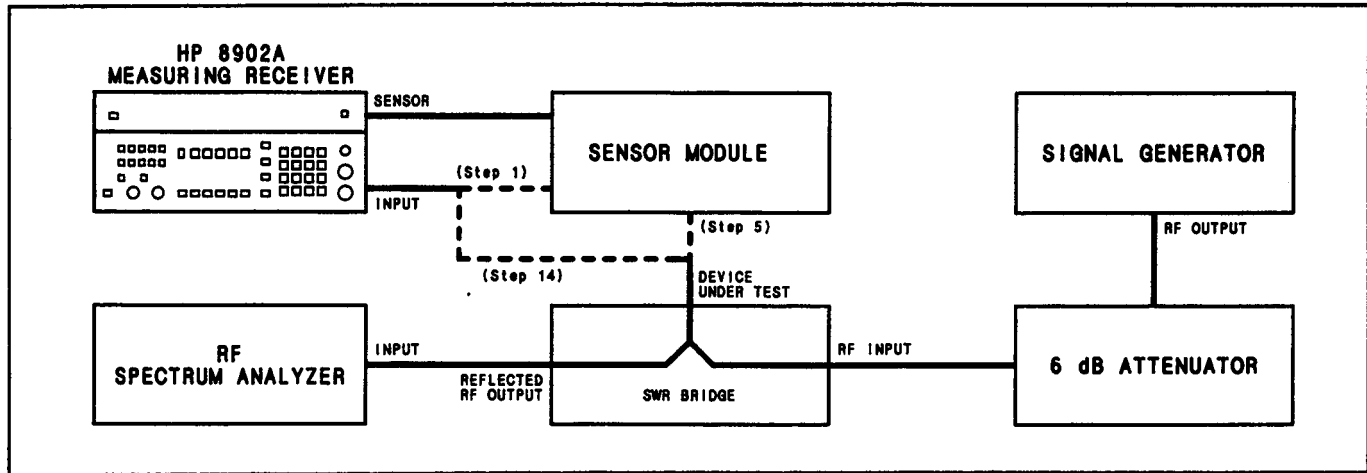

Figure 4-7. SWR Performance Test Setup

PROCEDURE

Sensor Module's Power Sensor SWR

NOTE

If a sensor module is not available, perform steps 1 through 4 except set the signal generator to -27 dBm. On the Measuring Receiver, press **FREQ** and key in 1.0 MHz. Then continue on at step 14.

1. Connect the equipment as shown in Figure 4-7. Connect the 6 dB attenuator directly to the RF input of the SWR bridge. Do not connect anything to the device-under-test input of the SWR bridge at this time.
2. Set the signal generator level to +3 dBm CW.
3. Set the spectrum analyzer to sweep 0 to 1 GHz. Set the display for 10 dB per vertical division.
4. With the sensor module disconnected from the SWR bridge, tune the signal generator from 0.1 to 1300 MHz and note the level of the signal. Adjust the spectrum analyzer's reference level, as needed, to set the average level of the signal to a convenient graticule reference. Resweep the signal generator and note the reference on the display.

NOTE

If the signal generator or spectrum analyzer is incapable of complete coverage of the frequency range, use whatever range is available. If the spectrum analyzer has variable persistence or storage capability, use it to store the reference line.

5. On the Measuring Receiver, press the blue key then press **INSTR PRESET** (the **AUTOMATIC OPERATION** key) to preset the instrument. Press **RF POWER**. Connect the sensor module to the SWR bridge. (See Figure 4-7.)

6. Resweep the signal generator and observe the level of the signal on the spectrum analyzer. At all frequencies between 2.5 and 1300 MHz the signal should be 23 dB below the reference signal. (Repeat the above steps and adjust the spectrum analyzer sweep, as required, to gather data for the highest and lowest frequencies.)

Worst Case Return Loss for RF Power Measurement: _____ –23 dB

Sensor Module's Thru-Path SWR

7. On the Measuring Receiver, press **FREQ.** Key in 1.6 SPCL and 1.0 MHz to set the input attenuation to 50 dB (range 1) and manual tune the instrument.

NOTE

In the steps that follow, ignore error messages in the Measuring Receiver's display. The messages indicate that the instrument is not tuned to the input signal. Also ignore any spurious signals on the spectrum analyzer display. The signals originate with the Measuring Receiver's local oscillator.

8. If necessary, re-establish the reference on the spectrum analyzer (with the sensor module disconnected from the SWR bridge). Then with the sensor module connected to the SWR bridge, resweep the signal generator. At all frequencies between 2.5 and 1300 MHz, the signal should be 17 dB below the reference signal.

Worst Case Return Loss for Tuned RF Level Measurement;
External Sensor Module; Range 1: _____ –17 dB

9. On the Measuring Receiver, key in 1.2 SPCL to set the input attenuation to 10 dB (range 2). Repeat step 8.

Worst Case Return Loss for Tuned RF Level Measurement;
External Sensor Module; Range 2: _____ –17 dB

10. Set the signal generator level to –27 dBm.
11. With the sensor module disconnected from the SWR bridge, sweep the signal generator as before and establish a convenient reference on the spectrum analyzer's display.
12. Reconnect the sensor module to the SWR bridge. On the Measuring Receiver, key in 1.7 SPCL to set the input gain to 24 dB. Resweep the signal generator. At all frequencies between 2.5 and 1300 MHz, the signal should be 14 dB below the reference signal.

Worst Case Return Loss for Tuned RF Level Measurement;
External Sensor Module; Range 3: _____ –14 dB

13. On the Measuring Receiver, key in 1.8 SPCL to set the input gain to 14 dB. Resweep the signal generator. At all frequencies between 2.5 and 1300 MHz, the signal should be 17 dB below the reference signal.

Worst Case Return Loss for Tuned RF Level Measurement;
External Sensor; 14 dB Gain Range: _____ –17 dB

Measuring Receiver Input SWR

14. Disconnect the sensor module from the SWR bridge and the Measuring Receiver's input. Connect the SWR bridge's RF input directly to the Measuring Receiver's INPUT connector. (See Figure 4-7.)
15. On the Measuring Receiver, key in 1.7 SPCL. Resweep the signal generator. At all frequencies between 2.5 and 1300 MHz, the signal should be 16 dB below the reference signal.

Worst Case Return Loss for Tuned RF Level Measurement;
Measuring Receiver Input; Range 3: _____ -16 dB

16. Set the signal generator level to +3 dBm.
17. Remove the SWR bridge from the Measuring Receiver's input. Sweep the signal generator as before and establish a convenient reference on the spectrum analyzer's display.
18. Reconnect the SWR bridge to the Measuring Receiver's INPUT connector. On the Measuring Receiver, key in 1.2 SPCL. Resweep the signal generator. At all frequencies between 2.5 and 1300 MHz, the signal should be 22 dB below the reference signal.

Worst Case Return Loss for Tuned RF Level Measurement;
Measuring Receiver Input; Range 2: _____ -22 dB

19. On the Measuring Receiver, key in 1.6 SPCL. Repeat step 18.

Worst Case Return Loss for Tuned RF Level Measurement;
Measuring Receiver Input; Range 1: _____ -22 dB

Performance Test 10—Tuned RF Level (Using a Step Attenuator)

Specification

Characteristic	Performance Limits	Conditions
TUNED RF LEVEL		
Frequency Range	2.5 to 1300 MHz	
Power Range	0 to -127 dBm 0 to -100 dBm	using IF synchronous detector using IF average detector
Relative Measurement Accuracy ⁽¹⁾	detector linearity + IF range-to-range error + RF range-to-range error + frequency drift error + noise error ± 1 digit	
Detector Linearity	± 0.02 dB ± 0.04 dB	IF synchronous detector IF average detector
IF Range-to-Range Error ⁽²⁾	± 0.02 dB/IF range change ± 0.05 dB/IF range change	IF ranges 1 to 5 IF range 6 to 7
RF Range-to-Range Error	± 0.04 dB/RF range change ± 0.06 dB/RF range change	tuned RF level RF power to tuned RF level
Frequency Drift Error	± 0.05 dB/kHz frequency drift from center of IF	
Noise Error ⁽³⁾	± 0.18 dB	
<p>(1) Accuracy is specified only at constant temperature and after RF range calibration is completed. Accuracy is affected by the residual FM of the source under test. If the peak residual FM deviation is greater than 50 Hz, measured over a 30s period in a 3 kHz bandwidth, tuned RF level measurements should be made using the IF average detector (30 kHz bandwidth) by using Special Function 4.4.</p> <p>(2) IF ranges 6 and 7 are used in automatic operation only for tuned RF level measurements below approximately -110 dBm for the IF synchronous detector, and below approximately -85 dBm for the IF average detector.</p> <p>(3) Using the IF synchronous detector and for levels ≥ -120 dBm, or for levels ≥ -110 dBm if Special Function 1.9 is implemented.</p>		

Description

This test checks the relative accuracy of the tuned RF level measurement mode for both the IF synchronous and IF average detectors. The linearity of the detectors (including the linearity of the internal dc voltmeter) is checked first. Linearity is measured by feeding a 50 MHz signal through a calibrated step attenuator into the Measuring Receiver. The instruments are set to produce a signal that is near the upper measurement limit of the detector, a level reference is set, and the range settings held. The attenuation is then increased by 10 dB and the drop in displayed level is compared against the increase in attenuation.

IF gain step accuracy is measured by setting the instruments to produce a signal level that is in the overlap region of adjacent IF gain steps. The change in the displayed level for each gain change (after correcting for the detector linearity error) is the IF gain step error.

Frequency drift error is measured for each detector by noting the change in level as the signal frequency is fine tuned slightly.

NOTE

The output level accuracy of the signal generator is of secondary importance. The test may be performed at other frequencies where the step attenuator or a piston attenuator is accurately calibrated.

An alternate procedure which uses a piston attenuator over a wide attenuation range is found in Performance Test 11—Tuned RF Level (Using a Piston Attenuator).

Equipment

Attenuator, Step 10 dB HP 355D Option J25
Signal Generator HP 8640B

Procedure

NOTE

In the following procedure the signal generator can be connected either to a sensor module (which is connected to the Measuring Receiver) or directly to the Measuring Receiver's INPUT connector. The procedure is written for the latter case.

Ignore the UNCAL and RECAL annunciators and error messages as they appear in the display.

Detector Linearity

1. Set the signal generator to 50 MHz CW at +3 dBm. Allow the equipment to warm up at least one-half hour.
2. Set the 10 dB step attenuator to 10 dB and connect it directly to the Measuring Receiver's INPUT connector. Connect the signal generator's output to the attenuator.
3. On the Measuring Receiver, press the blue key then press INSTR PRESET (the AUTOMATIC OPERATION key) to preset the instrument. Allow the Measuring Receiver to find the input signal and measure its frequency, then press the MHz key.
4. Set the signal generator level to -7 dBm.
5. On the Measuring Receiver, key in the following:
 - a. Key in S (shift) TUNED RF LEVEL.
 - b. Key in 4.6 SPCL to select the IF average detector with a measurement averaging time of 1s.
 - c. Key in 1.2 SPCL to set the input attenuation to 10 dB.
 - d. Key in 9.2 SPCL to set the IF gain to 10 dB.
 - e. Key in 49. S (Shift) 1 SPCL to display the voltage into the IF Average Detector. (Pressing S and 1 will cause "b" to appear in the display.) Adjust the signal generator level for a reading of approximately 3.0 (3 Vdc).
 - f. Press CLEAR.

- g. Press the blue key then press SET REF (the ZERO key) to enter the tuned RF attenuator measurement mode. (The display should read, on the average, between 99.99 and 100.01%. If it does not, press the blue key and SET REF again.)
- 6. Set the step attenuator to 20 dB. Divide the result in the Measuring Receiver's display (expressed as a ratio rather than percent or dB) by the attenuator's calibration factor for the 10 to 20 dB steps where the factor is expressed as a ratio (rather than dB). The computed result should be between 0.9931 and 1.0069 (± 0.04 dB).
For example, if the attenuator's calibration for the 10 dB step is -9.990 dB and for the 20 dB step is -20.015 dB, the difference is -10.025 dB. To express the dB difference as a ratio, compute $10^{(-10.025/20)} = 0.3153$. If the display reads 31.48% (that is, a ratio of 0.3148), the computed result is $0.3148/0.3153 = 0.9984$.

IF Average Detector Linearity: 0.9954 _____ 1.0046

- 7. Set the attenuator back to 10 dB. Set the signal generator's level to -33 dBm.
- 8. On the Measuring Receiver, key in the following:
 - a. Key in 4.2 SPCL to select the IF synchronous detector with a measurement averaging time of 1s.
 - b. Key in 50.6 SPCL to display the voltage into the IF Synchronous Detector. If necessary, fine adjust the signal generator level for a reading of approximately 3.0 (3 Vdc).
 - c. Press CLEAR.
 - d. Press the blue key and SET REF. (The display should read, on the average, between 99.99 and 100.01%. If it does not, press the blue key and SET REF again.)
- 9. Set the step attenuator to 20 dB. Divide the result in the Measuring Receiver's display by the attenuator's calibration factor for the 10 to 20 dB steps (as was done in step 6). Record the computed result for future reference. The computed result should be between 0.9977 and 1.0023 (± 0.02 dB).

IF Synchronous Detector Linearity: 0.9977 _____ 1.0023

IF Range-to-Range Accuracy

- 10. Set the step attenuator back to 10 dB.
- 11. On the Measuring Receiver, key in 9.1 SPCL to set the IF gain to 0 dB.
- 12. On the step attenuator, step up the attenuation in 10 dB steps as indicated in the following table. For each attenuator setting perform the following:
 - a. Press the blue key then SET REF to establish a level reference.
 - b. Key in the Special Function listed in the table.
 - c. Note the average value of several readings and record the result in the table.
 - d. Multiply the result recorded in step c by the result of step 9 and record the computed result for future reference. The computed result should be within the limits indicated in the table.

#	Attenuation of Step Attenuator (dB)	Special Function	Displayed Result (%)	Limits of Computed Result (%)		
				Lower	Actual	Upper
1	10	9.2	_____	99.77	_____	100.23
2	20	9.3	_____	99.77	_____	100.23
3	30	9.4	_____	99.77	_____	100.23
4	40	9.5*	_____	99.77	_____	100.23
5	50	9.6	_____	99.43	_____	100.58
6	60	9.7	_____	99.43	_____	100.58

* Key in 4.1 SPCL at this point.

Frequency Drift Error

- 13. Set the step attenuator to 10 dB.
- 14. On the Measuring Receiver, key in 4.2 SPCL. Key in 9.2 SPCL. Press the blue shift key and the SET REF key. Fine tune the signal generator slowly up and down over a 10 kHz range, or until Error 01 appears, stopping at frequent intervals to note the display. Note the maximum and minimum value on the Measuring Receiver's display. The difference between the maximum and minimum values should be less than 12.20

IF Synchronous Detector Frequency Drift Error: _____ 12.2%

Performance Test 11—Tuned RF Level (Using a Piston Attenuator)

Specification

Characteristic	Performance Limits	Conditions
TUNED RF LEVEL		
Frequency Range	2.5 to 1300 MHz	
Power Range	0 to -127 dBm 0 to -100 dBm	using IF synchronous detector using IF average detector
Relative Measurement Accuracy ⁽¹⁾	detector linearity + IF range-to-range error + RF range-to-range error + frequency drift error + noise error ±1 digit	
Detector Linearity	±0.02 dB ±0.04 dB	IF synchronous detector IF average detector
IF Range-to-Range Error ⁽²⁾	±0.02 dB/IF range change ±0.05 dB/IF range change	IF ranges 1 to 5 IF range 6 to 7
RF Range-to-Range Error	±0.04 dB/RF range change ±0.06 dB/RF range change	tuned RF level RF power to tuned RF level
Frequency Drift Error	±0.05 dB/kHz frequency drift from center of IF	
Noise Error ⁽³⁾	±0.18 dB	

(1) Accuracy is specified only at constant temperature and after RF range calibration is completed. Accuracy is affected by the residual FM of the source under test. If the peak residual FM deviation is greater than 50 Hz, measured over a 30s period in a 3 kHz bandwidth, tuned RF level measurements should be made using the IF average detector (30 kHz bandwidth) by using Special Function 4.4.

(2) IF ranges 6 and 7 are used in automatic operation only for tuned RF level measurements below approximately -110 dBm for the IF synchronous detector, and below approximately -85 dBm for the IF average detector.

(3) Using the IF synchronous detector and for levels ≤ -120 dBm, or for levels ≤ -110 dBm if Special Function 1.9 is implemented.

Description

This test checks the relative accuracy of the tuned RF level measurement mode for both the IF synchronous and IF average detectors. The linearity of the detectors (including the linearity of the internal dc voltmeter) is checked first. Linearity is measured by feeding a 30 MHz signal through a calibrated piston attenuator into the Measuring Receiver. The instruments are set to produce a signal that is near the upper measurement limit of the detector, a level reference is set, and the range settings held. The attenuation is then increased by 10 dB and the drop in displayed level is compared against the increase in attenuation.

IF gain step accuracy is measured by increasing the attenuation of the piston attenuator in 10 dB steps and comparing the displayed reading with the increase in attenuation.

Frequency drift error is measured for each detector by noting the change in level as the signal frequency is fine tuned slightly.

NOTE

The output level accuracy of the signal generator is of secondary importance. The test may be performed at other frequencies where the piston attenuator is accurately calibrated.

An alternate procedure which uses a calibrated 10 dB step attenuator in place of the piston attenuator is found in Performance Test 10—Tuned RF Level (Using a Step Attenuator).

Equipment

Attenuator, 3 dB (2 required)	HP 8491A Option 03
Attenuator, Piston	Eaton Type 32
Signal Generator	HP 8640B

Procedure

NOTE

In the following procedure an external sensor module is not used. If a sensor module is connected to the Measuring Receiver, disconnect it. Use short interconnect cables to prevent leakage from the input of the attenuator to the input of the Measuring Receiver. Triple-shielded coaxial cable is recommended.

Detector Linearity

1. Set the signal generator to 30 MHz CW at +10 dBm. Allow the equipment to warm up at least one-half hour.
2. Set the piston attenuator to 10 dB. Connect one fixed 3 dB attenuator directly to the piston attenuator's input and connect the other end of the 3 dB attenuator through a short, well-shielded cable to the signal generator's output connector.
3. Connect the other fixed 3 dB attenuator directly to the piston attenuator's output and connect the other end of the 3 dB attenuator to the Measuring Receiver's INPUT.
4. On the Measuring Receiver, press the blue key then press INSTR PRESET (the AUTOMATIC OPERATION key) to preset the instrument. Allow the Measuring Receiver to find the input signal and measure its frequency, then press MHz.

NOTE

In the following steps, ignore the RECAL and UNCAL annunciators and error messages.

5. On the Measuring Receiver, key in the following:
 - a. Key in S (shift) TUNED RF LEVEL.
 - b. Key in 4.6 SPCL to select the IF average detector with a measurement averaging time of 1s.

- c. Key in 1.2 SPCL to set the input attenuation to 10 dB.
 - d. Key in 9.3 SPCL to set the IF gain to 20 dB.
6. On the Measuring Receiver, key in 49. S (shift) 1 SPCL to set the instrument to measure and display the voltage from the IF Average Detector. (Pressing S and 1 will cause "b" to appear in the display.) Adjust the signal generator level for a reading of approximately 3.0 (3 Vdc).

NOTE

The piston attenuator is assumed to have 30 dB insertion loss at the 10 dB attenuation setting (20 dB residual insertion loss plus the added 10 dB). The two 3 dB attenuators add another 6 dB. If the piston attenuator has a residual insertion loss other than 20 dB, adjust the signal generator level as needed to obtain the 3 Vdc reading.

7. Press CLEAR to re-enter tuned RF level. Press the blue key then press SET REF (the ZERO key) to set the displayed reading as a reference. (The display should read between 99.99 and 100.01%. If it does not, press the blue key and SET REF again.)

NOTE

If calibration data is supplied with the piston attenuator, use the data in all subsequent measurements to correct for the attenuator error.

8. Set the piston attenuator to 20 dB. The display should read between 31.48 and 31.77% (that is, -10 ± 0.04 dB expressed in %).

IF Average Detector Linearity: 31.48 _____ 31.77%

9. Set the piston attenuator back to 10 dB.
10. On the Measuring Receiver, key in 4.2 SPCL to select the IF synchronous detector with a measurement averaging time of 1s. Key in 9.1 SPCL to set the IF gain to 0 dB.
11. On the Measuring Receiver, key in 50.6 SPCL to set the instrument to measure and display the voltage from the IF synchronous detector. Lower the signal generator level for a reading of approximately 3.0.
12. Press CLEAR. Press the blue key and SET REF. (The display should read between 99.99 and 100.01%. If it does not, press the blue key and SET REF again.)
13. Set the piston attenuator to 20 dB. The display should read between 31.55 and 31.70% (that is, -10 ± 0.02 dB).

IF Synchronous Detector Linearity: 31.55 _____ 31.70%

IF Range-to-Range Accuracy

14. Set the piston attenuator back to 10 dB.
15. Set the piston attenuator as indicated in the following table. For each step, key in the special function indicated in the table. For each step the display should read within the limits indicated in the table.

Special Function	Attenuation of Piston Attenuator (dB)	Limits of Displayed Result (%)		
		Lower	Actual	Upper
9.1	10		Ref	
9.2	20	31.55	_____	31.70
9.3	30	9.954	_____	10.046
9.4	40	3.141	_____	3.184
9.5	50	0.9908	_____	1.0093
9.6	60	0.3115	_____	0.3210
9.7	70	0.09795	_____	0.10209

Frequency Drift Error

16. On the Measuring Receiver, key in 9.1 SPCL.
17. Set the piston attenuator to approximately 10 dB.
18. On the Measuring Receiver, press the blue shift key and the SET REF key. Fine tune the signal generator slowly up and down over a 10 kHz range, or until an Error 01 appears, stopping at frequent intervals to note the display. Note the maximum and minimum value on the Measuring Receiver's display. The difference between the maximum and minimum values should be less than 12.20% (1.0 dB).

IF Synchronous Detector Frequency Drift Error: _____ 12.20%

Performance Test 12—High-Selectivity Filters (Options 032 and 033)

Specification

SELECTIVE POWER: Filter Shape

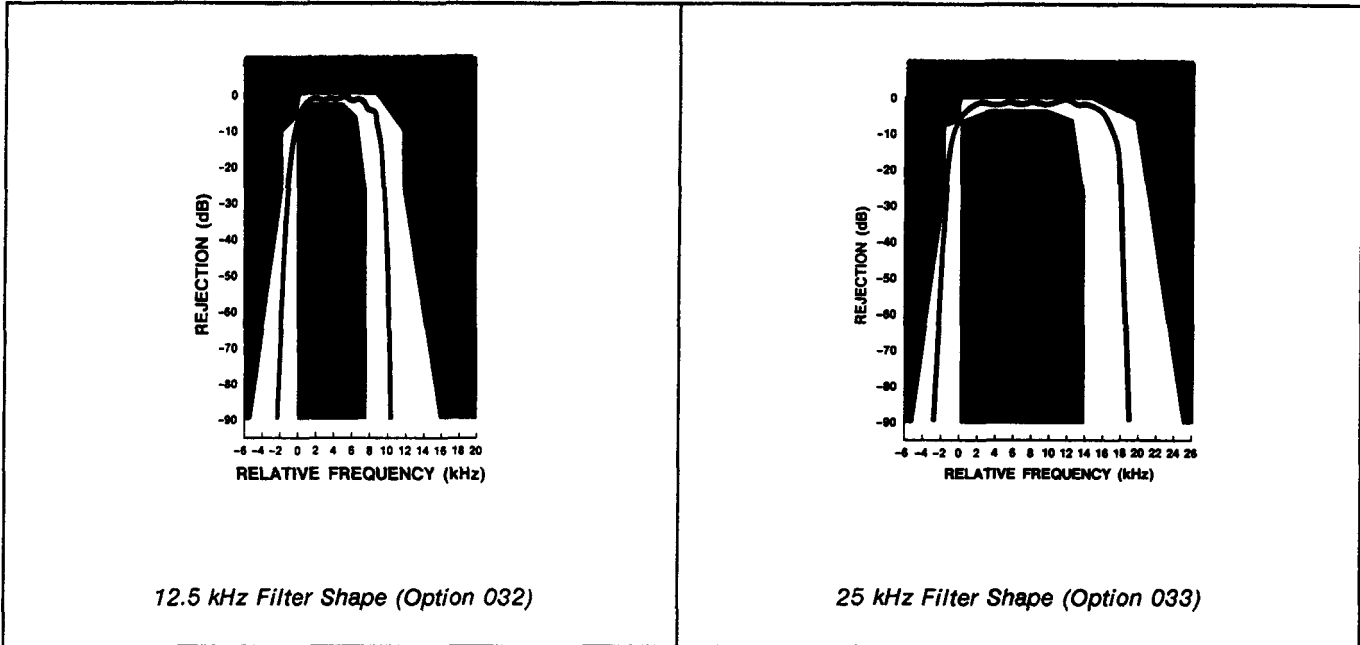

Description

The accuracy of the high-selectivity filters is tested by feeding a 455 kHz CW signal directly into the IF via the front-panel input connector. As the frequency of the input is changed, the shape of the IF is determined.

NOTE

This procedure tests only instruments with the 12.5 kHz Adjacent Channel Filter (Option 032) or 25 kHz Adjacent Channel Filter (Option 033) or both. Depending on the combination of these filters with the other available filter options (Options 035 and 037), either filter can be defined as the “wide” or “narrow” filter with regards to Special Function 24, which is used in the procedure. Follow the procedure or procedures which apply to the instrument’s particular option combination.

Equipment

Signal Generator HP 8640B or HP 3336C

Procedure

NOTE

In the following procedure the signal generator can be connected either to a sensor module (which is connected to the Measuring Receiver) or directly to the Measuring Receiver's INPUT connector. The procedure is written for the latter case.

Initial Setup

1. Set the signal generator to 455.0 kHz CW at +3 dBm. Connect the signal generator's output to the Measuring Receiver's INPUT. Allow the equipment to warm up at least one-half hour.

"Wide" Filter Test—Option Combination 032 and 037

2. On the Measuring Receiver, key in the following:
 - a. Press the blue key then press INSTR PRESET (the AUTOMATIC OPERATION key) to preset the instrument.
 - b. Key in 100 MHz to inhibit automatic tuning.
 - c. Key in 24.0 SPCL to initialize the high-selectivity level measurement.
 - d. Key in 3.1 SPCL to remove the RF input high-pass filter.
 - e. Key in 24.1 SPCL to read the IF level.
3. Slowly tune the frequency of the signal generator up and down until the peak reading is found.
4. On the Measuring Receiver, key in 24.1 SPCL and 24.2 SPCL to establish and display the current IF level as a level reference. (The display should read 0 dB.)
5. Tune the signal generator down until the first minimum is found. The display should read -2 dB or higher (that is, between -2 and 0 dB).

12.5 kHz Filter: Loss at First Minimum: -2 dB _____

6. Tune the signal generator down until the display reads -6.00 dB. Record the signal generator's frequency.

12.5 kHz Filter: Lower 6 dB Frequency: _____ kHz

7. Tune the signal generator down 1.6 kHz. The display should read -30 dB or less (that is, more negative).

12.5 kHz Filter: Loss at 1.6 kHz Below Lower 6 dB Corner: _____ -30 dB

8. Tune the signal generator down another 3 kHz. The display should read -80 dB or less.

12.5 kHz Filter: Loss at 4.6 kHz Below Lower 6 dB Corner: _____ -80 dB

9. Tune the signal generator up until the display reads 0 dB, then continue on until the display reads -6.00 dB. Record the signal generator's frequency.

12.5 kHz Filter: Upper 6 dB Frequency: _____ kHz

10. Subtract the reading of step 9 from the reading of step 6. The difference should be between 6.4 and 10.4 kHz.

12.5 kHz Filter: 6 dB Bandwidth: 6.4 _____ 10.4 kHz

11. Tune the signal generator up 12 kHz above the frequency recorded in step 6. The display should read -30 dB or less.

12.5 kHz Filter: Loss at 12 kHz Above Lower 6 dB Corner: _____ -30 dB

12. Tune the signal generator up another 3 kHz. The display should read -80 dB or less.

12.5 kHz Filter: Loss at 15 kHz Above Lower 6 dB Corner: _____ -80 dB

“Wide” Filter Test—Option Combination 032 and 033 or 033 and 037

13. Perform step 1, then on the Measuring Receiver, key in the following:
- Press the blue key then press INSTR PRESET (the AUTOMATIC OPERATION key) to preset the instrument.
 - Key in 100 MHz to inhibit automatic tuning.
 - Key in 24.0 SPCL to initialize the high-selectivity level measurement.
 - Key in 3.1 SPCL to remove the RF input high-pass filter.
 - Key in 24.1 SPCL to read the IF level.
14. Slowly tune the frequency of the signal generator up and down until the peak reading is found.
15. On the Measuring Receiver, key in 24.1 SPCL and 24.2 SPCL to establish and display the current IF level as a level reference. (The display should read 0 dB.)
16. Tune the signal generator down until the first minimum is found. The display should read -2 dB or higher (that is, between -2 and 0 dB).

25 kHz Filter: Loss at First Minimum: -2 dB _____

17. Tune the signal generator down until the display reads -6.00 dB. Record the signal generator's frequency.

25 kHz Filter: Lower 6 dB Frequency: _____ kHz

18. Tune the signal generator down 1.6 kHz. The display should read -30 dB or less (that is, more negative).

25 kHz Filter: Loss at 1.6 kHz Below Lower 6 dB Corner: _____ -30 dB

19. Tune the signal generator down another 3 kHz. The display should read -80 dB or less.

25 kHz Filter: Loss at 4.6 kHz Below Lower 6 dB Corner: _____ -80 dB

20. Tune the signal generator up until the display reads 0 dB, then continue on until the display reads -6.00 dB. Record the signal generator's frequency.

25 kHz Filter: Upper 6 dB Frequency: _____ kHz

21. Subtract the reading of step 20 from the reading of step 17. The difference should be between 12.4 and 16.9 kHz.

25 kHz Filter: 6 dB Bandwidth: 12.4 _____ 16.9 kHz

22. Tune the signal generator up 18.5 kHz above the frequency recorded in step 17. The display should read -30 dB or less.

25 kHz Filter: Loss at 18.5 kHz Above Lower 6 dB Corner: _____ -30 dB

23. Tune the signal generator up another 3 kHz. The display should read -80 dB or less.

25 kHz Filter: Loss at 21.5 kHz Above Lower 6 dB Corner: _____ -80 dB

“Narrow” Filter Test—Option Combination 032 and 033 or 032 and 035

24. Perform step 1, then on the Measuring Receiver, key in the following:

- a. Press the blue key then press INSTR PRESET (the AUTOMATIC OPERATION key) to preset the instrument.
- b. Key in 100 MHz to inhibit automatic tuning.
- c. Key in 24.0 SPCL to initialize the high-selectivity level measurement.
- d. Key in 3.1 SPCL to remove the RF input high-pass filter.
- e. Key in 24.3 SPCL to read the IF level.

25. Slowly tune the frequency of the signal generator up and down until the peak reading is found.

26. On the Measuring Receiver, key in 24.3 SPCL and 24.4 SPCL to establish and display the current IF level as a level reference. (The display should read 0 dB.)

27. Tune the signal generator down until the first minimum is found. The display should read -2 dB or higher (that is, between -2 and 0 dB).

12.5 kHz Filter: Loss at First Minimum: -2 dB _____

28. Tune the signal generator down until the display reads -6.00 dB. Record the signal generator's frequency.

12.5 kHz Filter: Lower 6 dB Frequency: _____ kHz

29. Tune the signal generator down 1.6 kHz. The display should read -30 dB or less (that is, more negative).

12.5 kHz Filter: Loss at 1.6 kHz Below Lower 6 dB Corner: _____ -30 dB

30. Tune the signal generator down another 3 kHz. The display should read -80 dB or less.

12.5 kHz Filter: Loss at 4.6 kHz Below Lower 6 dB Corner: _____ -80 dB

31. Tune the signal generator up until the display reads 0 dB, then continue on until the display reads -6.00 dB. Record the signal generator's frequency.

12.5 kHz Filter: Upper 6 dB Frequency: _____ kHz

32. Subtract the reading of step 31 from the reading of step 28. The difference should be between 6.4 and 10.4 kHz.

12.5 kHz Filter: 6 dB Bandwidth: 6.4 _____ 10.4 kHz

33. Tune the signal generator up 12 kHz above the frequency recorded in step 28. The display should read -30 dB or less.

12.5 kHz Filter: Loss at 12 kHz Above Lower 6 dB Corner: _____ -30 dB

34. Tune the signal generator up another 3 kHz. The display should read -80 dB or less.

12.5 kHz Filter: Loss at 15 kHz Above Lower 6 dB Corner: _____ -80 dB

“Narrow” Filter Test—Option Combination 033 and 035

35. Perform step 1, then on the Measuring Receiver, key in the following:
 - a. Press the blue key then press INSTR PRESET (the AUTOMATIC OPERATION key) to preset the instrument.
 - b. Key in 100 MHz to inhibit automatic tuning.
 - c. Key in 24.0 SPCL to initialize the high-selectivity level measurement.
 - d. Key in 3.1 SPCL to remove the RF input high-pass filter.
 - e. Key in 24.3 SPCL to read the IF level.
36. Slowly tune the frequency of the signal generator up and down until the peak reading is found.
37. On the Measuring Receiver, key in 24.3 SPCL and 24.4 SPCL to establish and display the current IF level as a level reference. (The display should read 0 dB.)
38. Tune the signal generator down until the first minimum is found. The display should read -2 dB or higher (that is, between -2 and 0 dB).

25 kHz Filter: Loss at First Minimum: -2 dB _____

39. Tune the signal generator down until the display reads -6.00 dB. Record the signal generator's frequency.

25 kHz Filter: Lower 6 dB Frequency: _____ kHz

40. Tune the signal generator down 1.6 kHz. The display should read -30 dB or less (that is, more negative).

25 kHz Filter: Loss at 1.6 kHz Below Lower 6 dB Corner: _____ -30 dB

41. Tune the signal generator down another 3 kHz. The display should read -80 dB or less.

25 kHz Filter: Loss at 4.6 kHz Below Lower 6 dB Corner: _____ -80 dB

42. Tune the signal generator up until the display reads 0 dB, then continue on until the display reads -6.00 dB. Record the signal generator's frequency.

25 kHz Filter: Upper 6 dB Frequency: _____ kHz

43. Subtract the reading of step 42 from the reading of step 39. The difference should be between 12.4 and 16.9 kHz.

25 kHz Filter: 6 dB Bandwidth: 12.4 _____ 16.9 kHz

44. Tune the signal generator up 18.5 kHz above the frequency recorded in step 39. The display should read -30 dB or less.

25 kHz Filter: Loss at 18.5 kHz Above Lower 6 dB Corner: _____ -30 dB

45. Tune the signal generator up another 3 kHz. The display should read -80 dB or less.

25 kHz Filter: Loss at 21.5 kHz Above Lower 6 dB Corner: _____ -80 dB

Performance Test 12a

30KHZ (CELLULAR RADIO) ALTERNATE CHANNEL FILTER – OPTION 035

Description

Option 035 Performance Verification

This test is to be performed on Option 030 instruments containing Option 035 as one of the alternate channel filters. In this test an HP 8662A (or level accuracy equivalent alternative) is used to simulate both an in-channel and adjacent channel signal. The signal generator is first tuned in-channel so that the reference can be set for the adjacent channel power measurement. The signal generator is then tuned to the adjacent channel and the LO shifted to measure the signal generator. The output level of the signal generator is varied to exercise different combinations of IF gain.

Equipment

Signal Generator..... HP 8662A

Procedure

Initial Setup

1. Set the signal generator to 150MHz CW at 0 dBm. Connect the signal generator output to the Measuring Receiver's RF Input. Allow all equipment 30 minute warmup minimum.

Filter Test of Option 030 Combination Which Includes Option 035

2. On the Measuring Receiver, key in the following:
 - a. 41.0SP (Performs instrument PRESET)
 - b. 150 MHz (Manually tunes the LO)
 - c. 24.0SP (Initializes Option 030)
 - d. 24.1SP (Selects Option 035 filter, displays IF reference level value)
 - e. 30 kHz UP (Increments LO up one channel spacing)
 - f. 24.2SP (Displays Option 035 filter ratio level value)
3. Offset the signal generator UP one channel spacing by incrementing frequency 30 kHz (150.030 MHz). The Measuring Receiver should display approximately 0 dB.
4. Change signal generator power level to -75 dBm. Read the ratio displayed on the Measuring Receiver. If the display is slightly unstable due to noise, then average the readings.
LEVEL RATIO -75dB (± 1.5 dB)
5. Change signal generator power level to -65 dBm. Read the ratio displayed on Measuring Receiver.
LEVEL RATIO -65dB (± 1.5 dB)
6. Change signal generator power level to -45 dBm. Read the ratio displayed on Measuring Receiver.
LEVEL RATIO -45dB (± 1.5 dB)
7. Change signal generator power level to -25 dBm. Read the ratio displayed on Measuring Receiver.
LEVEL RATIO -25dB (± 1.5 dB)
8. Change signal generator power level to -10 dBm. Read the ratio displayed on Measuring Receiver.
LEVEL RATIO -10dB (± 1.5 dB)

Performance Test 12b

CARRIER NOISE FILTER - OPTION 037

Description

Option 037 Performance Verification

This test is to be performed on Option 030 instruments containing Option 037 as one of the alternate channel filters. In this test an HP 8662A (or level accuracy equivalent alternative) is used to simulate both an in-channel and adjacent channel signal. The signal generator is first tuned in-channel so that the reference can be set for the adjacent channel power measurement. The signal generator is then tuned to the adjacent channel and the LO shifted to measure the signal generator. The output level of the signal generator is varied to exercise different combinations of IF gain. Testing is done using an HP 8660 as an external LO source.

Equipment

SOURCE Signal Generator HP 8662A
 EXTERNAL LO Signal Generator HP 8660

Procedure

Initial Setup

9. Set the SOURCE signal generator to 800 MHz CW at 0 dBm and connect it to the Measuring Receiver's RF Input. Set the EXTERNAL LO signal generator to 800.455 MHz at 0 dBm and connect it to the Measuring Receiver's LO INPUT port on the rear panel. Allow all equipment 30 minute warmup minimum.

Filter Test of Option 030 Combination Which Includes Option 037

10. On the Measuring Receiver, key in the following:
 - a. 41.0SP (Perform instrument PRESET)
 - b. 1200 MHz (Manual tune LO to eliminate internal LO interference)
 - c. 23.1SP (Select external LO)
 - d. 24.0SP (Initialize Option 030)
 - e. 24.5SP (Select Option 037 filter, displays IF Reference level value)
 - f. 24.6SP (Displays Option 037 filter ratio level value)
11. Offset EXTERNAL LO signal generator UP 10 kHz (800.465 MHz).
12. Offset SOURCE signal generator UP 10 kHz (800.010 MHz).
13. Change signal generator power level to -75 dBm. Read the ratio displayed on Measuring Receiver. If the display is slightly unstable due to noise, then average the readings.
 LEVEL RATIO -75dB (±1.5dB)
14. Change signal generator power level to -65 dBm. Read the ratio displayed on Measuring Receiver.
 LEVEL RATIO -65dB (±1.5dB)
15. Change the signal generator power level to -45 dBm. Read the ratio displayed on the Measuring Receiver.
 LEVEL RATIO -45dB (±1.5dB)

16. Change the signal generator power level to -25 dBm. Read the ratio displayed on the Measuring Receiver.

LEVEL RATIO -25dB ($\pm 1.5\text{dB}$)

17. Change the signal generator power level to -10 dBm. Read the ratio displayed on the Measuring Receiver.

LEVEL RATIO -10dB ($\pm 1.5\text{dB}$)

Performance Test 13

HIGH-SELECTIVITY GAIN (OPTION SERIES 030)

Specification

Characteristic	Performance Limits	Conditions
SELECTIVE POWER		
Frequency Range	10 to 1300 MHz	
Carrier Power Range	+30 to -20 dBm +30 to -10 dBm	12.5, 25, and 30 kHz filters carrier noise filter
Relative Measurement Accuracy	±0.5 dB ±0.5 dB	levels > -95 dBc; 12.5, 25, and 30 kHz filters levels > -129 dBc/Hz; carrier noise filter

Description

This test checks the relative accuracy of the selective power measurement mode. The linearity of the IF rms detector (including the linearity of the internal dc voltmeter) is checked first. Linearity is measured by feeding a 455 kHz signal directly into the IF via the front-panel connector. The level is set to produce a signal that is near the upper measurement limit of the detector, a level reference is set, and the range settings held. The signal level is then decreased by precisely 5 dB, and the drop in displayed level is compared against the decrease in level.

IF gain step accuracy is measured by increasing the attenuation of the attenuator in 5 dB steps and comparing the displayed reading with the increase in attenuation.

Equipment

Signal Generator..... HP 3336C

Procedure

NOTE

In the following procedure the signal generator can be connected either to a sensor module (which is connected to the Modulation Analyzer) or directly to the Modulation Analyzer's INPUT connector. The procedure is written for the latter case.

Detector Linearity

1. Set the signal generator to 455 kHz CW at +3 dBm. Connect the signal generator's output to the Modulation Analyzer's INPUT. Allow the equipment to warm up at least one-half hour.

2. On the Modulation Analyzer, key in the following:
 - a. Press the blue key then press INSTR PRESET (the AUTOMATIC OPERATION key) to preset the instrument.
 - b. Key in 100 MHz to inhibit automatic tuning.
 - c. Key in 24.0 SPCL to initialize the high-selectivity level measurement.
 - d. Key in 3.1 SPCL to remove the RF input high-pass filter.
 - e. Key in 24.1 SPCL to read the IF level.
 - f. Key in 49.C SPCL (C is yellow shift key and digit 2) to select and display the output of the IF rms detector and to inhibit IF ranging.
3. Adjust the level of the signal generator for a displayed reading of 2.500.
4. Decrease the signal generator level by exactly 5 dB. Divide the displayed reading by 1.406 and record the result.

IF RMS Detector Linearity: _____

IF Gain Accuracy

5. On the Modulation Analyzer, key in 0.390 SPCL, 0.3 S (Shift) 4 S 4 SPCL, and 0.3 S 30 SPCL to set the IF gain to 0 dB. Key in 49.C SPCL.
6. Increase the signal generator level for a displayed reading of 1.000.
7. Decrease the signal generator level by the exact amount indicated in the following table. For each setting, key in the Special Function(s) indicated, then key in 49.C SPCL. Multiply the displayed result by the result of step 4. The computed result should be between 0.944 and 1.059 (that is, ± 0.5 dB).

Decrease in Signal Generator Level (dB)	Special Function	Displayed Level	Limits of Computed Result		
			Lower	Actual	Upper
5	0.3 S 4 S 3	_____	0.944	_____	1.059
5	0.3 S 4 S 1	_____	0.944	_____	1.059
5	0.3 S 4 7	_____	0.944	_____	1.059
5	0.3 S 4 S 4, 0.391	_____	0.944	_____	1.059
0	0.392	_____	0.944	_____	1.059
0	0.394	_____	0.944	_____	1.059
0	0.390, 0.3 S 31	_____	0.944	_____	1.059

Performance Test 14

TUNED RF LEVEL

Specification

Characteristic	Performance Limits	Conditions
TUNED RF LEVEL Relative Accuracy	$\pm 0.015 \text{ dB} + 0.010 \text{ dB}/10 \text{ dB}$ $\pm 0.015 \text{ dB} + 0.050 \text{ dB}/10 \text{ dB}$	0.000 dBm to -100.000 dBm -100.001 dBm to -127.000 dBm

Description

This test checks the relative accuracy of the HP 8902A Option 050 Tuned RF Level measurement mode for the IF synchronous detector using the HP 11812A.

NOTE

The output level accuracy of the signal generator is of secondary importance.

Equipment

Signal Generator HP 8640B
 Step Attenuator HP 11812A

Procedure

NOTE

In the following procedure make direct connections between test equipment, avoiding cables and adapters, where possible. Turn on all equipment and allow it to warm up for 30 minutes before performing this test.

Tuned RF Level Accuracy with Step Attenuator

1. Connect the equipment as shown in Figure 4-1.
2. Setup:
 - a. Set the signal generator output to 30 MHz at +20 dBm CW.
 - b. Set the Step Attenuator to 0 dB.
3. Procedure:
 - a. On the Measuring Receiver press INSTR PRESET (blue key then green key).
 - b. Wait for the Measuring Receiver to display 30 MHz. Then Press the MHz key to manual tune the Measuring Receiver.
 - c. Press S (Yellow key), TUNED RF LEVEL. Wait for a measurement to be displayed.
 - d. Key in 39.9 SPCL to clear any previous calibration factors for the Tuned RF Level measurement.

- e. Key in 32.1 SPCL and 4.1 SPCL to enable 0.001 dB resolution and 10 second averaging.
- f. Press the LOG/LIN key for a log display in dB.
- g. Wait for a measurement to be displayed.
- h. Press SET REF (blue key and zero key) to establish the current level as a reference.
- i. The Measuring Receiver display should now be 0.000 dB \pm 0.003 dB.

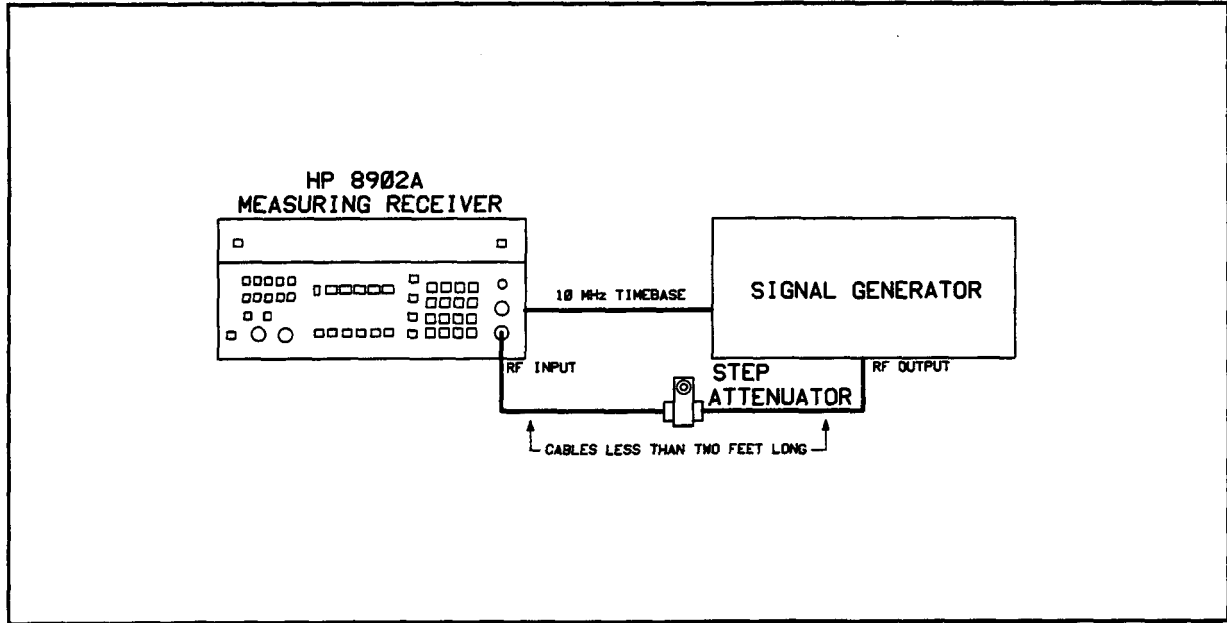

Figure 4-8. Tuned RF Level Performance Test Setup

4. Measure 0 dBm to -50 dBm Error:

- a. Set the Step Attenuator as indicated in the following table and record the Measuring Receiver readings in the column labeled "HP 8902A Reading (dB)". (Take the average of three readings.)
- b. Record the Step Attenuator calibrated value for each setting in the column labeled "Step Attenuator Value (dB)".
- c. Determine the Measuring Receiver error as indicated in the column labeled "Calculated Error". Record the error in this column.
- d. When the RECAL annunciator lights, press CALIBRATE and wait for the calibration to be made. (Recalibration will take approximately 1 minute.)

Step Attenuator Setting (dB)	Step Attenuator Value (dB)	HP 8902A Reading (dB)	Lower Limit	Calculated Error	Upper Limit
0	A1= 0.000 dB	A= _____	-0.015 dB	A1- A _____	0.015 dB
10	B1= _____	B= _____	-0.025 dB	B1- B _____	0.025 dB
20	C1= _____	C= _____	-0.035 dB	C1- C _____	0.035 dB
30	D1= _____	D= _____	-0.045 dB	D1- D _____	0.045 dB
40	E1= _____	E= _____	-0.055 dB	E1- E _____	0.055 dB
50	F1= _____	F= _____	-0.065 dB	F1- F _____	0.065 dB
0	G1= 0.000 dB	G= _____	-0.015 dB	G1- G _____	0.015 dB

5. Measure -50 dBm to -100 dBm Error:

- a. Reduce the signal generator level by 50 dB.
- b. Wait for a measurement to be displayed.
- c. On the Measuring Receiver, press the blue key and SET REF to establish a new ratio reference.
- d. Repeat step 4 using the following table.

Step Attenuator Setting (dB)	Step Attenuator Value (dB)	HP 8902A Reading (dB)	Lower Limit	Calculated Error	Upper Limit
0	A1= 0.000 dB	A= _____	-0.015 dB	A1- A _____	0.015 dB
10	B1= _____	B= _____	-0.025 dB	B1- B _____	0.025 dB
20	C1= _____	C= _____	-0.035 dB	C1- C _____	0.035 dB
30	D1= _____	D= _____	-0.045 dB	D1- D _____	0.045 dB
40	E1= _____	E= _____	-0.055 dB	E1- E _____	0.055 dB
50	F1= _____	F= _____	-0.065 dB	F1- F _____	0.065 dB
0	G1= 0.000 dB	G= _____	-0.015 dB	G1- G _____	0.015 dB

6. Measure -100 dBm to -120 dBm Error:

- a. Reduce the signal generator level by 50 dB.
- b. Wait for a measurement to be displayed.
- c. On the Measuring Receiver, press the blue key and SET REF to establish a new ratio reference.
- d. If the Measuring Receiver does not display 0.000 dB ±0.003, press blue key and SET REF again.
- e. Repeat step 4 using the following table.

Step Attenuator Setting (dB)	Step Attenuator Value (dB)	HP 8902A Reading (dB)	Lower Limit	Calculated Error	Upper Limit
0	A1= 0.000 dB	A= _____	-0.015 dB	A1- A _____	0.015 dB
10	B1= _____	B= _____	-0.065 dB	B1- B _____	0.065 dB
20	C1= _____	C= _____	-0.115 dB	C1- C _____	0.115 dB
0	D1= 0.000 dB	D= _____	-0.015 dB	D1- D _____	0.015 dB

Table 4-1. Performance Test Record (1 of 7)

Hewlett-Packard Company Model 8902A Measuring Receiver				
		Tested By _____		
Serial Number _____		Date _____		
Test No.	Test Description	Results		
		Minimum	Actual	Maximum
1	AM PERFORMANCE TEST			
	AM Accuracy at 10 kHz Rate			
	AM Calibration Factor 40% AM Range	99%	_____	101%
	AM Calibration Factor 100% AM Range	99%	_____	101%
	Residual AM		_____	0.01%
	AM Distortion			
	20 kHz Rate; 50% AM		_____	0.3%
	20 kHz Rate; 95% AM		_____	0.6%
	20 Hz Rate; 95% AM		_____	0.6%
	20 Hz Rate; 50% AM		_____	0.3%
	AM Flatness			
	AM Flatness (Maximum Difference)		_____	0.8% REL
	AM Accuracy			
	1.5 MHz IF; 50 kHz Rate	98.9% REL	_____	101.1% REL
	1.5 MHz IF; 100 kHz Rate	96.9% REL	_____	103.1% REL
	1.5 MHz IF; 50 Hz Rate	98.9% REL	_____	101.1% REL
	1.5 MHz IF; 20 Hz Rate	96.9% REL	_____	103.1% REL
455 kHz IF; 20 Hz Rate	96.9% REL	_____	103.1% REL	
455 kHz IF; 50 Hz Rate	97.9% REL	_____	102.1% REL	
455 kHz IF; 10 kHz Rate	97.9% REL	_____	102.1% REL	
AM Rejection				
With FM; 455 kHz IF		_____	20 Hz	
With FM; 1.5 MHz IF		_____	20 Hz	
With Φ M; 1.5 MHz IF		_____	0.030 rad	
2	FM PERFORMANCE TEST			
	Residual FM			
	Residual FM at 560 MHz; 50 Hz to 3 kHz bandwidth		_____	4 Hz
	FM Accuracy at 10 kHz Rate			
	FM Calibration Factor; 40 kHz Modulation Range	99%	_____	101%
FM Calibration Factor; 400 kHz Modulation Range	99%	_____	101%	
FM Accuracy; 4 kHz Modulation Range	12.35% REL	_____	12.65% REL	

Table 4-1. Performance Test Record (2 of 7)

Test No.	Test Description	Results		
		Minimum	Actual	Maximum
2	FM PERFORMANCE TEST (cont'd)			
	FM Distortion, Accuracy, and Rejection—1.5 MHz IF			
	FM Distortion at 100 kHz Rate; 100 kHz Peak Deviation		_____	0.1%
	FM Accuracy at 50 kHz Rate	98.9 kHz	_____	101.1 kHz
	FM Accuracy at 100 kHz Rate	94.9 kHz	_____	105.1 kHz
	FM Accuracy at 50 Hz Rate	98.9 kHz	_____	101.1 kHz
	FM Accuracy at 20 Hz Rate	94.9 kHz	_____	105.1 kHz
	FM Rejection at 1 kHz Rate; 50 kHz Peak Deviation		_____	0.2%
	FM Distortion, Accuracy, and Rejection—455 kHz IF			
	FM Rejection at 1 kHz Rate; 5 kHz Peak Deviation		_____	0.2%
	FM Accuracy at 10 kHz Rate	9.79 kHz	_____	10.21 kHz
	FM Accuracy at 20 Hz Rate	9.79 kHz	_____	10.21 kHz
FM Distortion at 10 kHz; 10 kHz Peak Deviation		_____	0.1%	
3	ΦM PERFORMANCE TEST			
	ΦM Accuracy			
	Modulation Rate (Hz)	Average FM Deviation (kHz)		
	200	50	242.4 rad	257.6 rad
	1 000	250	242.4 rad	257.6 rad
	20 000	250	12.0 rad	13.0 rad
	20 000	4	0.193 rad	0.207 rad
	10 000	25	2.39 rad	2.61 rad
	10 000	2.5	0.239 rad	0.261 rad
	1 000	25	24.0 rad	26.0 rad
	200	5	24.0 rad	26.0 rad
	ΦM Distortion			
1 kHz Rate; 400 rad Peak Deviation; 1.5 MHz IF		_____	0.1%	
1 kHz Rate; 40 rad Peak Deviation; 455 kHz IF		_____	0.1%	
4	AUDIO FILTERS PERFORMANCE TEST			
	Rate (Hz)	Filter		
	200	50 Hz HP FILTER	98.99% REL	101.01% REL
	2 000	50 Hz HP FILTER	98.99% REL	101.01% REL
	1 000	300 Hz HP FILTER	98.99% REL	101.01% REL
	10 000	300 Hz HP FILTER	98.99% REL	101.01% REL
	1 000	3 kHz LP FILTER	98.99% REL	101.01% REL
	100	3 kHz LP FILTER	98.99% REL	101.01% REL
	10 000	15 kHz LP FILTER	98.99% REL	101.01% REL
	1 000	15 kHz LP FILTER	98.99% REL	101.01% REL
	10 000	≥20 kHz LP FILTER	98.99% REL	101.01% REL
	1 000	≥20 kHz LP FILTER	98.99% REL	101.01% REL

Table 4-1. Performance Test Record (3 of 7)

Test No.	Test Description	Results			
		Minimum	Actual	Maximum	
5	AUDIO MEASUREMENTS PERFORMANCE TEST				
	Audio RMS Accuracy				
	50 Hz Rate	2.88 Vrms	_____	3.12 Vrms	
	500 Hz Rate	2.88 Vrms	_____	3.12 Vrms	
	5 kHz Rate	2.88 Vrms	_____	3.12 Vrms	
	40 kHz Rate	2.88 Vrms	_____	3.12 Vrms	
	40 kHz Rate	96 mVrms	_____	104 mVrms	
	5 kHz Rate	96 mVrms	_____	104 mVrms	
	500 Hz Rate	96 mVrms	_____	104 mVrms	
	50 Hz Rate	96 mVrms	_____	104 mVrms	
	Audio Counter Range and Sensitivity				
	Rate (Hz)	RF Level (dBm, V)			
	20	+16.5, 3	0.01998 kHz	_____	0.02002 kHz
	20	-13.0, 0.1	0.01998 kHz	_____	0.02002 kHz
	1 000	-13.0, 0.1	0.99997 kHz	_____	1.00003 kHz
	1 000	+16.5, 3	0.99997 kHz	_____	1.00003 kHz
	250 000	+16.5, 3	249.997 kHz	_____	250.003 kHz
	250 000	-13.0, 0.1	249.997 kHz	_____	250.003 kHz
	Residual Noise and Distortion				
	400 Hz Input at 100 mV		_____	0.3%	
	400 Hz Input at 3V		_____	0.3%	
1 kHz Input at 3V		_____	0.3%		
1 kHz Input at 100 mV		_____	0.3%		
Distortion Accuracy					
1 kHz Rate; 2nd harmonic		0.89%	_____	1.12%	
1 kHz Rate; 3rd harmonic		0.89%	_____	1.12%	
1 kHz Rate; 4th harmonic		0.89%	_____	1.12%	
1 kHz Rate; 5th harmonic		0.89%	_____	1.12%	
400 Hz Rate; 2nd harmonic		0.89%	_____	1.12%	
400 Hz Rate; 3rd harmonic		0.89%	_____	1.12%	
400 Hz Rate; 4th harmonic		0.89%	_____	1.12%	
400 Hz Rate; 5th harmonic		0.89%	_____	1.12%	
6	POWER REFERENCE PERFORMANCE TEST (USING REFERENCE COMPARISON)				
	RF Power Reference Accuracy	98.1% REL	_____	101.9% REL	
7	POWER REFERENCE PERFORMANCE TEST (USING DC SUBSTITUTION)				
	RF Power Reference Power	0.988 mW	_____	1.012 mW	

Table 4-1. Performance Test Record (4 of 7)

Test No.	Test Description	Results		
		Minimum	Actual	Maximum
8	POWER METER PERFORMANCE TEST			
	Serial Prefix 2305A to 2449A			
	Zero Set			
	Special Function 10.1		_____	0.06 μ W
	Special Function 10.2		_____	0.1 μ W
	Special Function 10.3		_____	0.001 μ W
	Special Function 10.4		_____	0.01 mW
	Special Function 10.5		_____	0.1 mW
	Serial Prefix 2451A and above			
	Zero Set			
	Special Function 10.1		_____	0.051 0.051 μ W
	Special Function 10.2		_____	0.06 .06 μ W
	Special Function 10.3		_____	0.2 0.2 μ W
	Special Function 10.4		_____	0.001 mW
	Special Function 10.5		_____	0.01 mW
	Range-to-Range Error			
	Special Function 10.1; 10 μ W Range	9.90 μ W	_____	10.10 μ W
Special Function 10.2; 100 μ W Range	99.4 μ W	_____	100.6 μ W	
Special Function 10.4; 10 mW Range	9.94 mW	_____	10.06 mW	
Special Function 10.5; 100 mW Range	99.0 mW	_____	101.0 mW	
Accuracy within a Range	0.099 mW	_____	0.101 mW	
9	SWR PERFORMANCE TEST			
	Sensor Module's Power Sensor SWR			
	Worst Case Return Loss for RF Power Measurement		_____	-23 dB
	Sensor Module's Thru-Path SWR			
	Worst Case Return Loss for Tuned RF Level Measurement			
	External Sensor Module; Range 1		_____	-17 dB
	External Sensor Module; Range 2		_____	-17 dB
	External Sensor Module; Range 3		_____	-14 dB
	External Sensor; 14 dB Gain Range		_____	-17 dB
	Measuring Receiver Input SWR			
	Worst Case Return Loss for Tuned RF Level Measurement			
Measuring Receiver Input; Range 3		_____	-16 dB	
Measuring Receiver Input; Range 2		_____	-22 dB	
Measuring Receiver Input; Range 1		_____	-22 dB	

Table 4-1. Performance Test Record (5 of 7)

Test No.	Test Description	Results		
		Minimum	Actual	Maximum
10	TUNED RF LEVEL PERFORMANCE TEST (USING A STEP ATTENUATOR)			
	Detector Linearity			
	IF Average Detector Linearity	0.9931	_____	1.0069
	IF Synchronous Detector Linearity	0.9977	_____	1.0023
	IF Range-to-Range Accuracy			
	Special Function 9.2	99.77%	_____	100.23%
	Special Function 9.3	99.77%	_____	100.23%
	Special Function 9.4	99.77%	_____	100.23%
	Special Function 9.5	99.77%	_____	100.23%
	Special Function 9.6	99.43%	_____	100.58%
	Special Function 9.7	99.43%	_____	100.58%
Frequency Drift Error				
IF Synchronous Detector Frequency Drift Error		_____	12.2%	
11	TUNED RF LEVEL PERFORMANCE TEST (USING A PISTON ATTENUATOR)			
	Detector Linearity			
	IF Average Detector Linearity	31.55%	_____	31.70%
	IF Synchronous Detector Linearity	31.59%	_____	31.66%
	IF Range-to-Range Accuracy			
	Special Function 9.2	31.55%	_____	31.70%
	Special Function 9.3	9.954%	_____	10.046%
	Special Function 9.4	3.141%	_____	3.184%
	Special Function 9.5	0.9908%	_____	1.0093%
	Special Function 9.6	0.3115%	_____	0.3210%
	Special Function 9.7	0.09795%	_____	0.10209%
Frequency Drift Error				
IF Synchronous Detector Frequency Drift Error		_____	12.2%	
12	HIGH-SELECTIVITY FILTERS PERFORMANCE TEST (OPTIONS 032 AND 033)			
	"Wide" Filter Test—Option Combination 032 and 037			
	12.5 kHz Filter: Loss at First Minimum	-2 dB	_____	
	12.5 kHz Filter: Loss at 1.6 kHz Below Lower 6 dB Corner		_____	-30 dB
	12.5 kHz Filter: Loss at 4.6 kHz Below Lower 6 dB Corner		_____	-80 dB
	12.5 kHz Filter: 6 dB Bandwidth	6.4 kHz	_____	10.4 kHz
	12.5 kHz Filter: Loss at 12 kHz Above Lower 6 dB Corner		_____	-30 dB
	12.5 kHz Filter: Loss at 15 kHz Above Lower 6 dB Corner		_____	-80 dB

Table 4-1. Performance Test Record (6 of 7)

Test No.	Test Description	Results		
		Minimum	Actual	Maximum
12	HIGH-SELECTIVITY FILTERS PERFORMANCE TEST (OPTIONS 032 AND 033) (cont'd)			
	“Wide” Filter Test—Option Combination 032 and 033 or 033 and 037			
	25 kHz Filter: Loss at First Minimum	-2 dB	_____	
	25 kHz Filter: Loss at 1.6 kHz Below Lower 6 dB Corner		_____	-30 dB
	25 kHz Filter: Loss at 4.6 kHz Below Lower 6 dB Corner		_____	-80 dB
	25 kHz Filter: 6 dB Bandwidth	12.4 kHz	_____	16.9 kHz
	25 kHz Filter: Loss at 18.5 kHz Above Lower 6 dB Corner		_____	-30 dB
	25 kHz Filter: Loss at 21.5 kHz Above Lower 6 dB Corner		_____	-80 dB
	“Narrow” Filter Test—Option Combination 032 and 033 or 032 and 035			
	12.5 kHz Filter: Loss at First Minimum	-2 dB	_____	
	12.5 kHz Filter: Loss at 1.6 kHz Below Lower 6 dB Corner		_____	-30 dB
	12.5 kHz Filter: Loss at 4.6 kHz Below Lower 6 dB Corner		_____	-80 dB
	12.5 kHz Filter: 6 dB Bandwidth	6.4 kHz	_____	10.4 kHz
	12.5 kHz Filter: Loss at 12 kHz Above Lower 6 dB Corner		_____	-30 dB
	12.5 kHz Filter: Loss at 15 kHz Above Lower 6 dB Corner		_____	-80 dB
	“Narrow” Filter Test—Option Combination 033 and 035			
	25 kHz Filter: Loss at First Minimum	-2 dB	_____	
	25 kHz Filter: Loss at 1.6 kHz Below Lower 6 dB Corner		_____	-30 dB
	25 kHz Filter: Loss at 4.6 kHz Below Lower 6 dB Corner		_____	-80 dB
	25 kHz Filter: 6 dB Bandwidth	12.4 kHz	_____	16.9 kHz
	25 kHz Filter: Loss at 18.5 kHz Above Lower 6 dB Corner		_____	-30 dB
25 kHz Filter: Loss at 21.5 kHz Above Lower 6 dB Corner		_____	-80 dB	
13	HIGH-SELECTIVITY GAIN PERFORMANCE TEST (OPTION SERIES 030)			
	IF Gain Accuracy			
	Special Function 0.3 S 4 S 3	0.944	_____	1.059
	Special Function 0.3 S 4 S 1	0.944	_____	1.059
	Special Function 0.3 S 4 7	0.944	_____	1.059
	Special Functions 0.3 S 4 S 4, 0.391	0.944	_____	1.059
	Special Function 0.392	0.944	_____	1.059
	Special Function 0.394	0.944	_____	1.059
Special Functions 0.390, 0.3 S 31	0.944	_____	1.059	

Table 4-1. Performance Test Record (7 of 7)

Hewlett-Packard Company HP 8902A Option 050				
		Tested By _____		
Serial Number _____		Date _____		
Test No.	Test Description	Results		
		Minimum	Actual	Maximum
14	TUNED RF LEVEL PERFORMANCE TEST (OPTION 050)			
	Relative Accuracy Error with HP 11812A			
	Attenuator Setting (-0 dBm to -50 dBm)			
	0 dB	-0.015 dB	_____	0.015 dB
	10 dB	-0.025 dB	_____	0.025 dB
	20 dB	-0.035 dB	_____	0.035 dB
	30 dB	-0.045 dB	_____	0.045 dB
	40 dB	-0.055 dB	_____	0.055 dB
	50 dB	-0.065 dB	_____	0.065 dB
	0 dB	-0.015 dB	_____	0.015 dB
	Attenuator Setting (-50 dBm to -100 dBm)			
	0 dB	-0.015 dB	_____	0.015 dB
	10 dB	-0.025 dB	_____	0.025 dB
	20 dB	-0.035 dB	_____	0.035 dB
	30 dB	-0.045 dB	_____	0.045 dB
	40 dB	-0.055 dB	_____	0.055 dB
	50 dB	-0.065 dB	_____	0.065 dB
	0 dB	-0.015 dB	_____	0.015 dB
	Attenuator Setting (-100 dBm to -120 dBm)			
	0 dB	-0.015 dB	_____	0.015 dB
	10 dB	-0.065 dB	_____	0.065 dB
20 dB	-0.115 dB	_____	0.115 dB	
0 dB	-0.015 dB	_____	0.015 dB	

Table of Contents

	<u>Page</u>
Introduction	5-1
Safety Considerations	5-1
Equipment Required	5-2
Factory-Selected Components	5-2
Post-Repair Tests, Adjustments, and Checks	5-2
Related Adjustments	5-2
Adjustment 1—Power Supply	5-5
Adjustment 2—Internal Reference Frequency	5-6
Adjustment 3—RF Peak Detector Offset and Gain	5-7
Adjustment 4—Sampler Efficiency and Offset	5-8
Adjustment 5—LO Doubler Output Power and Balance	5-10
Adjustment 6—Voltmeter Offset and Sensitivity	5-12
Adjustment 7—15 kHz and >20 kHz Low-Pass Filter Gain	5-14
Adjustment 8—ALC Reference	5-15
Adjustment 9—FM Calibrator	5-16
Adjustment 10—FM Sensitivity	5-17
Adjustment 11—FM Flatness	5-18
Adjustment 12—FM Distortion and Incidental AM—1.5 MHz IF	5-20
Adjustment 13— Φ M Sensitivity	5-22
Adjustment 14—AM Calibrator	5-24
Adjustment 15—AM Sensitivity	5-25
Adjustment 16—FM Distortion and Incidental AM—455 kHz IF	5-26
Adjustment 17—Track-Tune Mode Offset	5-28
Adjustment 18—Power Reference (Using Reference Comparison)	5-29
Adjustment 19—Power Reference (Using DC Substitution)	5-31
Adjustment 20—Power Meter	5-34
Adjustment 21—Audio True RMS Detector and Notch Filter Gain	5-36
Adjustment 22—Battery Backup	5-38
Adjustment 23—Narrow 455 kHz IF Filter	5-39
Adjustment 24—IF Synchronous Detector	5-43

Section 5 ADJUSTMENTS

5-1. INTRODUCTION

This section contains adjustments and checks that assure peak performance of the Measuring Receiver. The instrument should be readjusted after repair or failure to pass a performance test. Allow a 30 minute warm-up prior to performing the adjustments. Removing the top cover is the only disassembly required for most adjustments.

To determine which performance tests and adjustments to perform after a repair, refer to paragraph 5-5, *Post-Repair Tests, Adjustments, and Checks*.

5-2. SAFETY CONSIDERATIONS

This section contains information, cautions, and warnings which must be followed for your protection and to avoid damage to the equipment.

WARNING

Adjustments described in this section are performed with power supplied to the instrument and with protective covers removed. Maintenance should be performed only by service trained personnel who are aware of the hazard involved (for example, fire and electrical shock). Where maintenance can be performed without power applied, the power should be removed.

Removal of the Measuring Receiver's bottom cover is not necessary to perform these adjustments. However, if the bottom cover is removed, hazardous voltage (≈ 120 Vac) is accessible.

A pin-to-pin voltage difference of 55 Vdc may be found on many of the Measuring Receiver's circuit board connectors. Be careful while working on the circuit boards with power supplied to the instrument.

If a circuit board is placed on an extender board, the possibility of coming in contact with 55 Vdc is greatly increased. Be careful while working on the circuit boards with power supplied. Work with one hand. Do not touch the extender board.

5-3. EQUIPMENT REQUIRED

Each adjustment procedure contains a list of required test equipment. The test equipment is identified by callouts in the test setup diagrams where included.

If substitutions must be made for the specified test equipment, refer to Table 1-3 in the *Operating Manual* for the minimum specifications. It is important that the test equipment meet the critical specifications listed in the table if the Measuring Receiver is to meet its performance requirements.

5-4. FACTORY-SELECTED COMPONENTS

Factory-selected components are identified on the schematics and parts list by an asterisk (*) which follows the reference designator. The normal value or range of the components is shown. The *Manual Changes* sheets will provide updated information pertaining to the selected components. Table 5-1 lists the reference designator, the criterion used for selecting a particular value, the normal value range, and the service sheet where the component part is shown.

5-5. POST-REPAIR TESTS, ADJUSTMENTS, AND CHECKS

Table 5-2 lists the performance tests, adjustments, and checks needed to calibrate or verify calibration of a repaired assembly. The tests, adjustments, and checks are classified by assembly repaired.

The table is also useful as a cross reference between performance tests and assemblies when the failure is a specification that is slightly out of limits.

For all repairs, perform the *Basic Functional Checks* in Section 3, *Adjustment 1—Power Supply* (but only adjust the +15V supply if it is out of limits), and the *Adjustment 2—Internal Reference Frequency*. The *Basic Functional Checks* utilize automatic tuning and measurement which exercises nearly every circuit in the instrument (except the Remote Interface Assembly).

5-6. RELATED ADJUSTMENTS

The procedures in this section can be done in any order, but it is advisable to check the power supply voltages and time base reference first.

Table 5-1. Factory Selected Components

Reference Designator	Service Sheet	Range of Values	Basis of Selection
A6C43 A6C51 A6L8	8	290 pF to 330 pF 300 pF to 600 pF 68 μ H to 80 μ H	If AM flatness peaks at 20 Hz and rolls off at 50 kHz, change A6L8 to 80 μ H and A6C43 to 290 pF. If AM flatness peaks at 50 kHz and is correct at 20 Hz, lower A6C51. Lowering A6C51 by 100 pF will decrease peaking about 0.3%.
A19C43 A19R63 A19R72 A19R74	17	4.7 pF to 15 pF 38.1 to 110 Ω 121 to 619 Ω 121 to 619 Ω	See <i>Adjustment 5—LO Doubler Output Power and Balance</i> .
A23C45 A23R55	18	1.8 pF to 2.7 pF 750 to 1780 Ω	See <i>Adjustment 4—Sampler Offset and Efficiency</i> .
A32R5 A32R2 A32VR2	3 3 3	7100 to 7500 Ω 1.47 k Ω 8.2V	See <i>Adjustment 18 or 19—Power Reference</i> .
A51R24 A51R32	29	19.6 k to 38.3 k Ω 9.09 k to 11 k Ω	See <i>Adjustment 9—FM Calibrator</i> .
A54R24	7	75 to 4640 Ω	See <i>Adjustment 24—IF Synchronous Detector</i> .
A54R25	7	5.6 M to 6.81 M Ω	If the instrument fails Test 2 of the IF Synchronous Detector Test (Special Function 53) and indicates Fault 8 (VCO slow sweep too fast or too slow), the VCO sweep rate can be increased by decreasing A54R25 to 5.6 M Ω (HP part number 0683-5655).

Table 5-2. Post-Repair Tests, Adjustments, and Checks (1 of 2)

Assembly Repaired	Test, Adjustment, or Check
A1 Keyboard and Display Assembly	Power-Up Checks Service Special Functions (Use 60.0 SPCL, Key Scan, and exercise all keys.)
A2 Audio Filter Assembly	Performance Test 1—AM Adjustment 7—15 kHz and >20 kHz Low-Pass Filter Gain Adjustment 15—AM Sensitivity
A3 Audio De-emphasis and Output Assembly	Performance Test 2—FM (FM Distortion—1.5 MHz IF only) Performance Test 3— Φ M Performance Test 4—Audio Filters Adjustment 13— Φ M Sensitivity
A4 FM Demodulator Assembly	Performance Test 2—FM Adjustment 10—FM Sensitivity Adjustment 11—FM Flatness
A5 Voltmeter Assembly	Adjustment 6—Voltmeter Offset and Sensitivity Service Special Functions (Use 49.N and 50.N SPCL, Display Internal Voltages, and check for reasonable readings.)
A6 AM Demodulator Assembly	Performance Test 1—AM Adjustment 8—ALC Reference Adjustment 12—FM Distortion and Incidental AM—1.5 MHz IF Adjustment 15—AM Sensitivity
A10 Power Supply Regulators Assembly	Adjustment 1—Power Supply
A11 Counter Assembly	Adjustment 2—Internal Reference Frequency Power-up Checks
A13 Controller Assembly	Adjustment 22—Battery Backup Power-Up Checks
A14 Remote Interface Assembly	HP-IB Functional Checks Power-Up Checks
A15 RF Input Control Assembly	
A16 RF Detector Assembly	Adjustment 3—RF Peak Detector Offset and Gain
A17 Input Mixer Assembly A18 IF Amplifier Assembly	Adjustment 12—FM Distortion and Incidental AM—1.5 MHz IF Adjustment 16—FM Distortion and Incidental AM—455 kHz IF
A19 LO Divider Assembly	Adjustment 5—LO Doubler Output Power and Balance (Doubler repairs only) Power-Up Checks
A20 LO Control Assembly	Performance Test 2—FM (Residual FM only) Power-Up Checks
A21 Low Frequency VCXO Filter Assembly	Power-Up Checks
A22 Low Frequency VCXO Assembly	Performance Test 2—FM (Residual FM only) Power-Up Checks
A23 Sampler Assembly	Performance Test 2—FM (Residual FM only) Adjustment 4—Sampler Efficiency and Offset Power-Up Checks
A24 High Frequency VCO Assembly	Performance Test 2—FM (Residual FM only) Power-Up Checks

Table 5-2. Post-Repair Tests, Adjustments, and Checks (2 of 2)

Assembly Repaired	Test, Adjustment, or Check
A25 Audio Motherboard Assembly A26 Power Supply Motherboard Assembly A27 Digital Motherboard Assembly A28 RF Mother Board Assembly A29 Series Regulator Heat Sink Assembly A30 Line Power Module	Power-Up Checks
A31 Remote Interface Connector Assembly	HP-IB Functional Checks
A32 Power Reference Oscillator Assembly	Performance Test 6 or 7—Power Reference Adjustment 18 or 19—Power Reference
A50 AM Calibrator Assembly	Performance Test 1—AM (AM Accuracy at 10 kHz only) Adjustment 14—AM Calibrator
A51 FM Calibrator Assembly	Performance Test 2—FM (FM Accuracy at 10 kHz only) Adjustment 9—FM Calibrator
A52 Audio Counter/Distortion Analyzer Assembly	Performance Test 5—Audio Measurements Adjustment 21—Audio True RMS Detector and Notch Filter Gain
A53 RF Power Assembly	Performance Test 8—Power Meter Adjustment 20—Power Meter Adjustment
A54 IF Synchronous Detector Assembly	Performance Test 10 or 11—Tuned RF Level Adjustment 24—IF Synchronous Detector Service Special Functions (Use Special Function 53.)
A55 IF Amplifier/Filter Assembly	Performance Test 10 or 11—Tuned RF Level Adjustment 23—Narrow 455 kHz IF Filter
A70 Amplifier/Switch Interconnect Assembly	
A71 IF Amplifier/Detector Assembly	Performance Test 13—High-Selectivity Gain
A72 IF Channel/Filter Assembly	Performance Test 12—High-Selectivity Filters Performance Test 13—High-Selectivity Gain
AT1 Input Attenuator AT2 10 dB Attenuator S1, S2 RF Switch U1 RF Amplifier U2 Limiter	Performance Test 9—SWR Performance Test 10 or 11—Tuned RF Level
Y1 Crystal Oscillator	Adjustment 2—Internal Reference Frequency

Adjustment 1—Power Supply

REFERENCE

Service Sheets 31 and 32.

DESCRIPTION

The +15V supply is adjusted, and the other supplies, which are dependent upon it, are checked.

EQUIPMENT

Digital Voltmeter HP 3455A

PROCEDURE

1. Set the voltmeter to measure +15 Vdc. Connect its input to A10TP3 (+15V SW).
2. Adjust A10R24 (+15V) for +14.99 to +15.01 Vdc at A10TP3.
3. Check the other supplies with the voltmeter as indicated in the following table.

2305A TO 2616A

Supply	Test Point	Voltage Limits (Vdc)	
		Minimum	Maximum
-15V	A10TP4	-15.2	-14.8
+5V	A10TP5	+4.9	+5.2
-5V	A10TP6	-5.2	-4.9
+40V	A10TP7	+40.5	+42.5

2618A AND ABOVE

Supply	Test Point	Voltage Limits (Vdc)	
		Minimum	Maximum
-15V	A10TP4	-15.2	-14.8
+5V	A10TP5	+5.1	+5.35
-5V	A10TP6	-5.4	-5.1
+40V	A10TP7	+40.5	+42.5

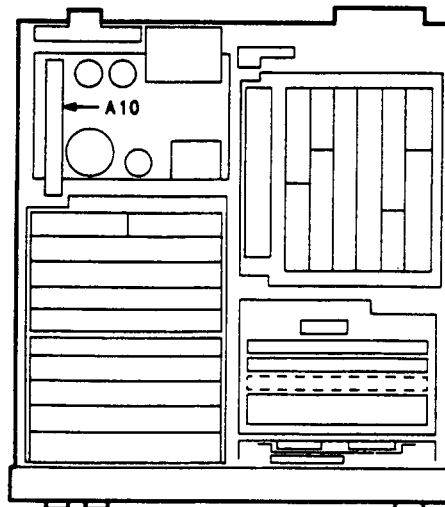

Adjustment 2—Internal Reference Frequency

Reference

Service Sheets 22 and 31.

Description

An oscilloscope, triggered by an external reference, is used to monitor the internal reference frequency. The internal reference frequency is adjusted for a stationary waveform on the oscilloscope.

Equipment

Frequency Standard House Standard
Oscilloscope HP 1740A

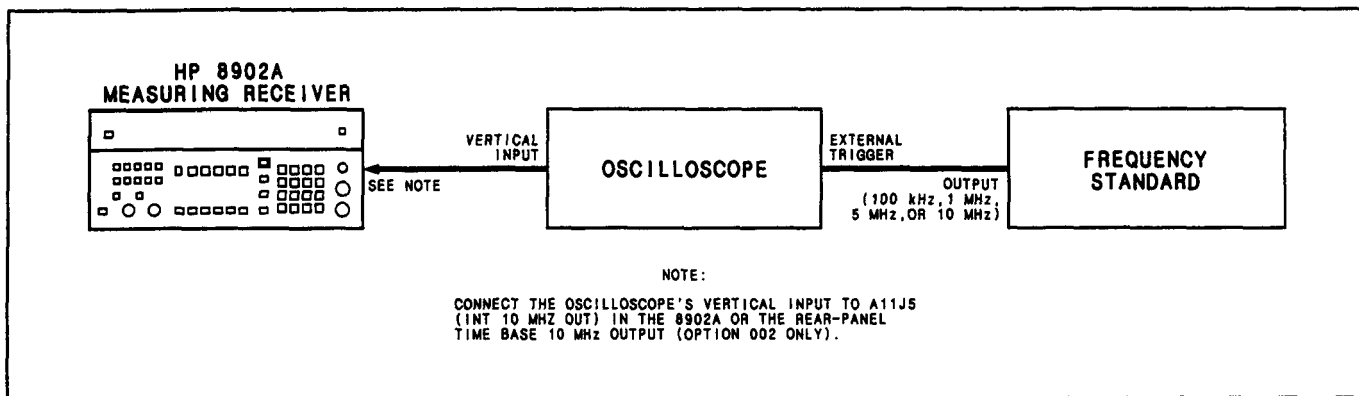

Figure 5-1. Internal Reference Frequency Adjustment Test Setup

Procedure

1. Connect the equipment as shown in Figure 5-1. Allow the equipment to warm up for 15 minutes. For Option 002, a warm-up of the Measuring Receiver of several days with covers on is recommended.
2. Set the oscilloscope's vertical sensitivity to view the Measuring Receiver's time base output. Set its horizontal scale for $10 \mu\text{s}$ per division. Set the oscilloscope to trigger externally.
3. Adjust A11C14 (10 MHz REF) or, for Option 002, Y1 (COARSE and FINE) for a stationary waveform. If adjusting A11C14, use a totally non-metallic adjustment tool.

NOTE

Movement of the waveform to the right at a rate of one division per second means that the Measuring Receiver's time base is low by 0.1 ppm.

*If the frequency of the internal reference is quite far off, the oscilloscope display may be difficult to interpret. In that case, connect the frequency standard directly to the Measuring Receiver's INPUT, press **FREQ**, and adjust the internal reference frequency for a display equal to the standard's frequency, then begin again at step 2.*

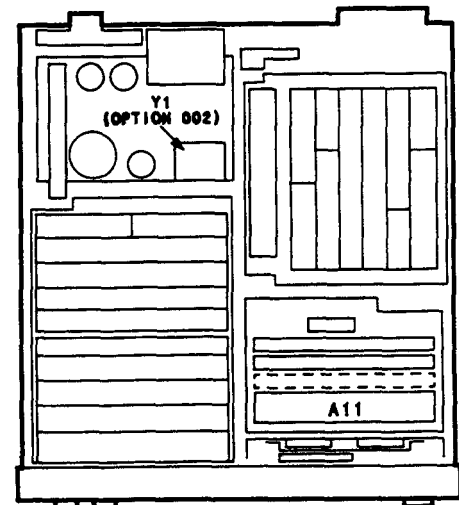

Adjustment 3—RF Peak Detector Offset and Gain

Reference

Service Sheet 4.

Description

With no RF input, the output from the RF peak detector is adjusted for 0 Vdc while monitoring it with the internal voltmeter. The internal 1 mW power reference is then connected to the instrument's input and the RF peak detector gain is adjusted for a reading equivalent to 1 mW.

Procedure

1. Press the blue key, then press INSTR PRESET (the AUTOMATIC OPERATION key) to preset the instrument. Key in 35.0 SPCL to measure RF level with the RF peak detector set to high gain. Key in 49.31 SPCL to set the voltmeter to measure and display the output of the RF peak detector.
2. Adjust A16R27 (DET OFS) for displayed readings that fall between 0.0000 and 0.0006. (The slight positive offset prevents negative readings which generate an error message in log mode.)
3. Connect CALIBRATION RF POWER OUTPUT to INPUT.
4. Key in 45.16 SPCL to turn on the RF power calibrator. Key in 49.31 SPCL. The display should read between 0.1800 and 0.2500. If it does not, proceed as follows.
 - a. Turn the instrument off. Remove both cables from the A16 RF Detector Assembly and extend the assembly.
 - b. Connect CALIBRATION RF POWER OUTPUT to A16J1 (RF IN). Connect AT1J1 (RF IN) to A16J2 (RF OUT) either by extending the the existing cable or by replacing it with a short jumper cable.
 - c. Turn the instrument on. Key in 35.0 SPCL. Key in 45.16 SPCL. Key in 49.31 SPCL.
 - d. Adjust A16R33 (DET GAIN) for a display between 0.2000 and 0.2300. (The nominal reading would be 0.2150.)
 - e. Re-install the A16 assembly and repeat steps 1 to 4.

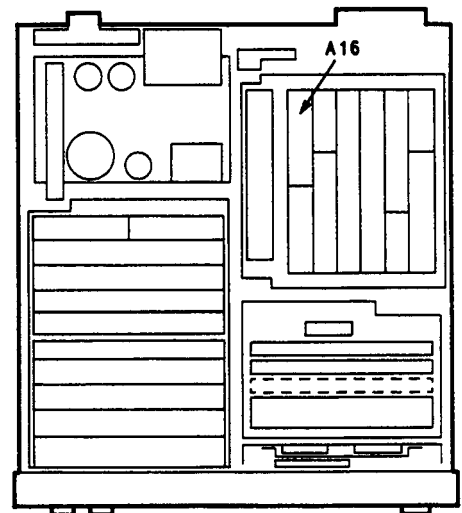

Adjustment 4—Sampler Efficiency and Offset

Reference

Service Sheet 18.

Description

Using the track-tune mode, the two signals into the sampler are configured so that the low-frequency VCXO is at a set frequency and the high-frequency VCO tracks the RF input signal. The output of the sampler is observed on an oscilloscope. The RF input is tuned to locate a zero-beat frequency at the sampler output then tuned for a 1 MHz beat. The sampler offset and efficiency (or frequency response) are then adjusted so that the dc offset is 50 mV and the amplitude of the 1 MHz waveform is the same as the zero beat.

NOTE

Improper adjustment of efficiency may result in the loop easily breaking or not attaining phase lock.

Equipment

Oscilloscope..... HP 1740A
Signal Source..... HP 8640B or HP 3336C

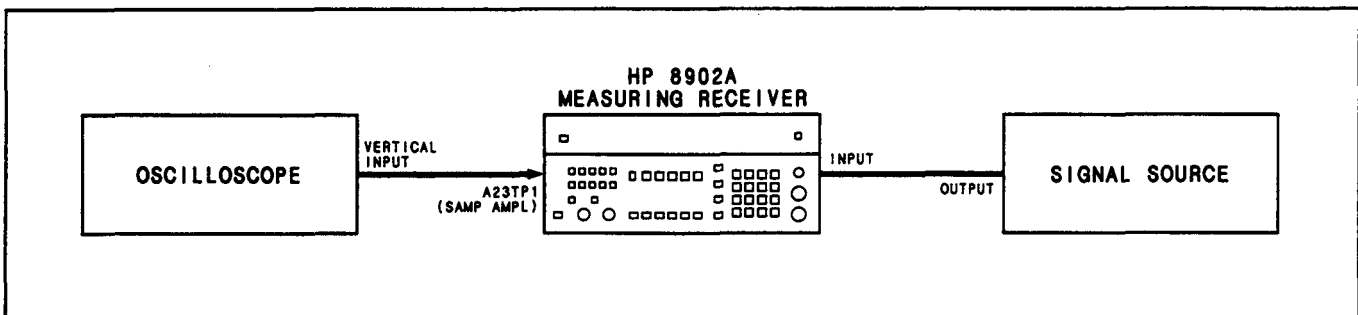

Figure 5–2. Sampler Efficiency and Offset Adjustment Test Setup

Procedure

1. Set the signal source to 18 MHz CW at 0 dBm.
2. Connect the equipment as shown in Figure 5–2. (The oscilloscope input should be ac coupled. The signal source can be connected either to a sensor module or directly the the Measuring Receiver's INPUT.)
3. Set the oscilloscope's vertical sensitivity to 0.2 V/division and horizontal scale for 10 μ s/division.
4. On the Measuring Receiver, press the blue key then press INSTR PRESET (the AUTOMATIC OPERATION key) to preset the instrument. Press TRACK MODE. If the instrument fails to tune to the 18 MHz signal, key in 18 MHz then press TRACK MODE.

5. Fine tune the signal source up slowly until a zero beat signal appears on the oscilloscope. Then increase the signal source frequency by 1 kHz. Note the frequency of the signal source. Note the peak-to-peak amplitude on the oscilloscope.

Signal Source Frequency: _____ MHz
 Waveform Amplitude: _____ mVpp

6. Tune the signal source up by 30.0 kHz. This tunes the high-frequency VCO up $32 \times 30 \text{ kHz} \approx 1 \text{ MHz}$ since the LO frequency is the HF VCO frequency divided by 32 on this band.
7. Adjust A23R34 (OFS) such that when the input coupling of the oscilloscope is changed from ac to dc the waveform shifts upward 50 mV. Adjust A23R34 only when the input coupling is set to dc.
8. Adjust A23R54 (EFF) for the same peak-to-peak amplitude on the oscilloscope as noted in step 5. If the adjustment has not enough range:
 - a. Set A23R54 fully ccw and repeat steps 5 to 7.
 - b. The signal amplitude step 5. If it is not, replace A23R55 by higher values of resistance as listed in the following table. If this still does not have enough effect, replace A23C45 with higher values of capacitance as listed in table below.
 - c. Adjust A23R54 for the same amplitude as noted in step 5.
9. Repeat step 7.
10. Key in 54.0 SPCL to run the LO tuning test. The display should show 0.

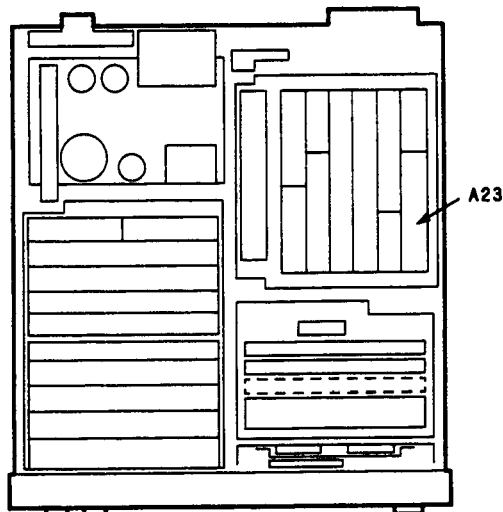

Part Numbers for A23R55 and A23C45

Resistance (ohms)	HP Part Number	Capacitance(pF)	HP Part Number
511	0757-0416	1.8	0160-4490
750	0757-0420	2.7	0160-3568
1000	0757-0280	3.3	0160-4382
1210	0757-0274	3.9	0160-4618
1470	0757-1094		
1780	0757-0278		

Adjustment 5—LO Doubler Output Power and Balance

Reference

Service Sheet 17.

Description

The power from the LO is monitored with a power meter while the LO is stepped through its doubler band. The bias and coupling components are changed as necessary to obtain the required power output. The LO is then monitored on a spectrum analyzer as the LO is swept slowly over its doubler band. The doubler balance is adjusted for minimum $\frac{1}{2}$ and $\frac{3}{2}$ harmonics of the doubled frequency.

NOTE

Excessive subharmonics can cause the LO to tune to a wrong frequency when automatically tuning.

Equipment

Sensor Module	HP 11722A
RF Spectrum Analyzer	HP 8559A/182T

Procedure

NOTE

In the following procedure, a power meter and power sensor combination can be substituted for the sensor module. The Measuring Receiver can then be left in the frequency measurement mode.

1. Connect the sensor module to the Measuring Receiver's SENSOR and INPUT connectors.
2. On the Measuring Receiver, press the blue key then press INSTR PRESET (the AUTOMATIC OPERATION key) to preset the instrument.
3. Zero and calibrate the sensor module using the RF power calibrator in the Measuring Receiver. Set LOG/LIN to read in dBm.
4. Connect the sensor module's input directly to A19J3 (LO OUT), or for Option 003, the rear-panel LO OUTPUT connector.
5. On the Measuring Receiver, press FREQ. Key in 650 MHz to set the LO to the bottom of its doubler band.
6. Step the LO frequency up in 50 000 kHz steps. (Key in 50 000 \uparrow kHz for the first step, then \uparrow kHz thereafter.) For each step, press FREQ to tune the LO, then press RF POWER and note the power reading. Do this until Error 20 or Error 15 is displayed. (The LO has reached the top of its range or the frequency is beyond the range of the calibration factors of the sensor module.) The power readings should be between +1.4 and +3.0 dBm. If the power readings are within range, continue with step 7. If the power readings are out of range, change the components on A19 according to the following guidelines.
 - a. To increase the power throughout the entire doubler band, decrease the value of A19R63. (Use values within the range 38.1 to 110 Ω .)

- b. To eliminate low-frequency roll-off, increase the value of A10C43. Do not use a value of C43 that is larger than necessary or the effectiveness of the high-pass filter is reduced. (Use values within the range 4.7 to 15 pF.)
 - c. To eliminate high-frequency roll-off, increase the values of both A19R72 and R74 equally. (Use values within the range 121 to 619Ω.)
 - d. The effect of changing these components is interactive, therefore, whenever a component is changed, the power must be rechecked over the entire doubler band.
7. Set the spectrum analyzer to view a +10 dBm signal with a 0 to 2 GHz span width and log display. Connect its RF input to A19J3 (LO OUT), or for Option 003, the rear-panel LO OUTPUT connector.
 8. On the Measuring Receiver, press the blue key then press INSTR PRESET. Key in 55.0 SPCL to cause the LO to sweep slowly over its doubler range.
 9. Adjust A19R41 (DBLR BAL) for the minimum level of the $\frac{1}{2}$ and $\frac{3}{2}$ harmonics of the doubled signal over the swept range. The $\frac{1}{2}$ and $\frac{3}{2}$ harmonics should be more than 30 dB below the doubled signal. The doubled signal sweeps from approximately 600 to 1300 MHz with a level of approximately +2 dBm.

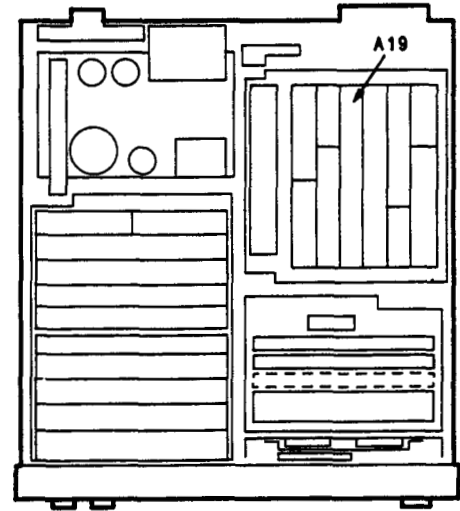

NOTE

To ease adjustment, note the frequency of the fundamental where harmonics are worst, manually tune to that frequency (use the frequency increment keys to assist in fine tuning), make the adjustment, then key in 55.0 SPCL and recheck the entire range. The sweep can be halted at any time by pressing the SPCL key.

Adjustment 6—Voltmeter Offset and Sensitivity

Reference

Service Sheets 14 and 15.

Description

The dc offsets of the audio peak and average detectors are first adjusted. The voltmeter sensitivity is then adjusted while comparing the displayed reading to the level read by an external dc voltmeter. The sensitivity of the average detector is adjusted while comparing the average mode to the peak mode when detecting a sinusoidal signal.

Equipment

Audio Oscillator HP 8903B
 Digital Voltmeter HP 3455A

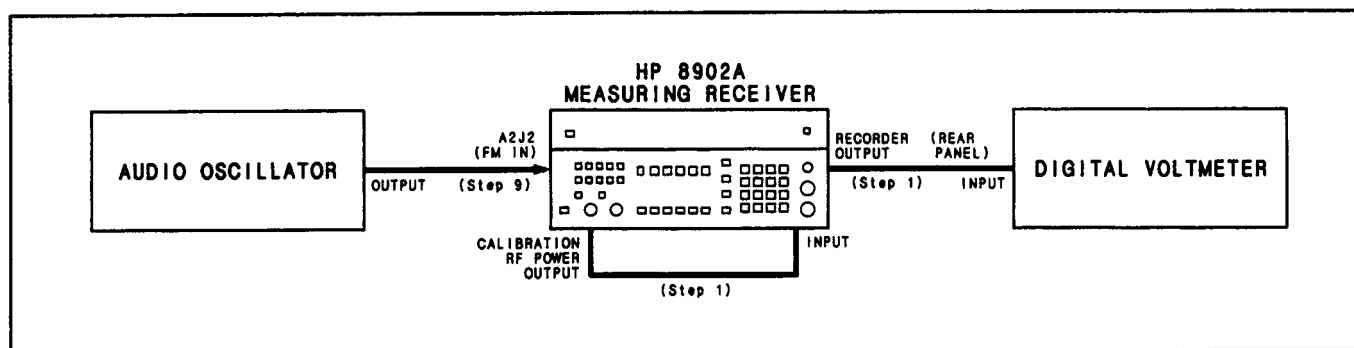
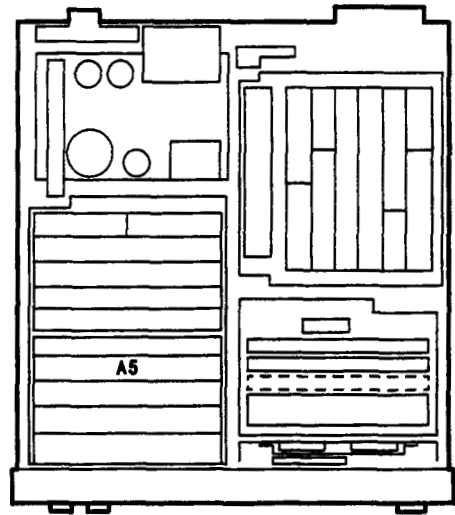

Figure 5-3. Voltmeter Offset and Sensitivity Adjustment Test Setup

Procedure

1. Connect the equipment as shown in Figure 5-3. Do not connect the audio oscillator to the Measuring Receiver at this time. (The Measuring Receiver's INPUT can be connected either directly to the CALIBRATION RF POWER OUTPUT or through a sensor module.)
2. On the Measuring Receiver, press the blue key then press INSTR PRESET (the AUTOMATIC OPERATION key) to preset the instrument. Key in 45.16 SPCL to turn on the RF power calibrator. (This provides a signal for the Measuring Receiver to tune to.)
3. On the Measuring Receiver, set HP FILTER to 300 Hz and LP FILTER to 3 kHz. Key in 2.3 SPCL to set the audio gain to minimum. Key in 0.110 SPCL to set the audio input and audio overvoltage detector to no input and no reset. Key in 49. S (shift) 0 SPCL to set the voltmeter to measure and display the audio peak detector output.
4. Adjust A5R38 (PK DET OFS) for a display between 0.0003 and 0.0007.
5. Key in 49.9 SPCL to set the voltmeter to measure and display the average detector output.
6. Set A5R2 (RECT OFS) fully ccw to shut off A5U3.
7. Adjust A5R18 (AVG OFS) for a display between -0.0001 and +0.0001.

8. Set A5R2 (RECT OFS) fully cw then slowly ccw until the display reads between 0.0004 and 0.0006.
9. Set the audio oscillator for 2 kHz at 1 Vrms. Connect its output to A2J2 (FM IN) of the Measuring Receiver as shown in Figure 5-3.
10. On the Measuring Receiver, press FM. Key in 49.0 S (shift) 0 SPCL to connect the output from the audio peak detector to the RECORDER OUTPUT.
11. Adjust the audio oscillator level until the external voltmeter reads between +1.999 and +2.001 Vdc.
12. Adjust A5R73 (VM SENS) for a display on the Measuring Receiver between 199.9 and 200.1, or if the level has drifted slightly, until the four digits of the display agree with the first four digits of the voltmeter reading to within ± 1 digit.
13. On the Measuring Receiver, key in 49.09 spcl.
14. Adjust A5R23 (AVG SENS) for a display on the Measuring Receiver between 141.3 and 141.5, or if the level has drifted slightly, until the four digits of the display equals the voltmeter reading to within ± 1 digit.
15. On the Measuring Receiver, press PEAK+. Note the display. Press PEAK-. The two readings of the display should agree to within ± 1 digit.
16. Perform *Adjustment 10—FM Sensitivity*, *Adjustment 13— Φ M Sensitivity*, and *Adjustment 15—AM Sensitivity*.



Adjustment 7—15 kHz and >20 kHz Low-Pass Filter Gain

Reference

Service Sheet 12.

Description

A signal generator is amplitude modulated at a 1 kHz rate. The signal is demodulated by the Measuring Receiver with no low-pass, audio filtering. Using the ratio feature, the demodulated signal is referenced to 100%. The low-pass filtering is then set to >20 kHz and 15 kHz, then the filter gain of each is adjusted for a reading of 100%.

Equipment

Signal Generator HP 8640B

Procedure

1. Set the signal generator to 11 MHz at 0 dBm with 30% AM at a 1 kHz rate. Connect its RF output to the Measuring Receiver's INPUT. (The signal source can be connected either to a sensor module or directly to the Measuring Receiver's INPUT.)
2. On the Measuring Receiver, press the blue key then press INSTR PRESET (the AUTOMATIC OPERATION key) to preset the instrument. Press AM. Set DETECTOR to AVG.
3. Set RATIO on (with LOG/LIN set for a linear display). The display should show between 99.95 and 100.05% REL.
4. Set LP FILTER to >20 kHz. Adjust A2R44 (>20 kHz LPF GAIN) for a display of 99.95 to 100.05% REL.
5. Set LP FILTER to 15 kHz. Adjust A2R40 (15 kHz LPF GAIN) for a display of 99.95 to 100.05% REL.

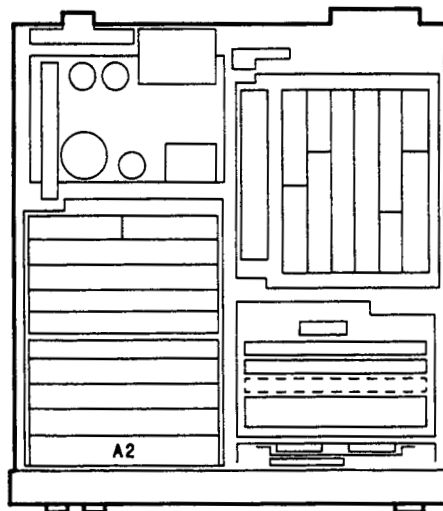

Adjustment 8—ALC Reference

Reference

Service Sheet 8.

Description

The ALC reference voltage is adjusted while monitoring it with the internal voltmeter.

Procedure

1. Connect the CALIBRATION RF POWER OUTPUT to the INPUT. (The CALIBRATION RF POWER OUTPUT can be connected either to a sensor module or directly to the Measuring Receiver's INPUT.)
2. Press the blue key then press INSTR PRESET (the AUTOMATIC OPERATION key) to preset the instrument. Key in 45.16 SPCL to turn on the RF power calibrator. (This provides a signal for the Measuring Receiver's input.) Key in 49. S (Shift) 1 SPCL to connect the internal voltmeter to a node which represents the average IF level which the ALC loop forces to equal the ALC reference.
3. Adjust A6R65 (ALC REF) for a display between 2.0970 to 2.1030.

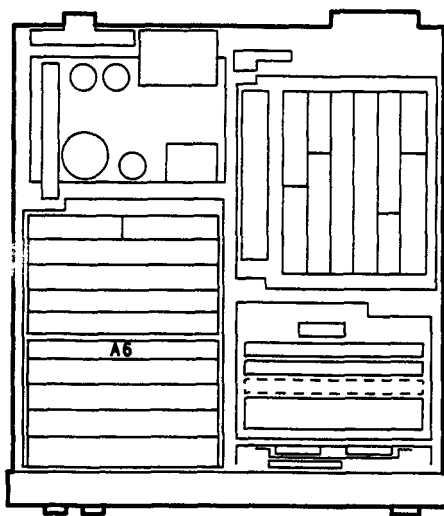

Adjustment 9—FM Calibrator

REFERENCE

Service Sheet 29.

DESCRIPTION

The FM calibrator is set to CW and its frequency is adjusted while being monitored by the internal counter. The calibrator is then set to modulate, and the symmetry is adjusted as the demodulated signal is measured with the peak+ and peak- detectors. The computed peak deviation is checked and if out of limits, a resistor is changed to bring the deviation within the proper limits.

NOTE

This calibration adjustment is not critical. Built-in safeguards minimize the possibility of erroneous calibration. If conditions exist that are out of calibration, the Measuring Receiver displays an error message.

PROCEDURE

1. Connect CALIBRATION AM/FM OUTPUT to INPUT. (The CALIBRATION AM/FM OUTPUT can be connected either to a sensor module or directly to the Measuring Receiver's INPUT.)
2. Key 12.1 SPCL and 46.3 SPCL. This sets the FM calibrator to CW and connects the internal counter to measure the calibrator's frequency.
3. Using a non-metallic tool, adjust A51C20 (FREQ) for a display between 1009000 and 1011000. If the frequency cannot be adjusted high enough, change A51R32 to 11 k Ω (HP part number 0757-0443).
4. Key in 12.2 SPCL then 5.1 SPCL. This sets the instrument to display the demodulated FM from the calibrator and sets the peak detector time constant to slow.
5. Alternately set the DETECTOR to PEAK+ and PEAK- and note the display for each setting. Adjust A51R12 (TRAPEZOID SYMM) until the readings are the same for both detectors within ± 0.010 kHz.
6. Key in 12.0 SPCL to set the instrument to display the computed FM deviation from the FM calibrator. The display should read between 30 and 38 kHz. If the peak deviation exceeds these limits, alter the value of A51R24. Increasing the value of A51R24 by 10% will decrease the peak deviation by approximately 2.5 kHz. Use resistors indicated in the following table.

Part Numbers for A51R24

Resistance (k Ω)	HP Part Number
26.1	0698-3159
28.7	0698-3449
31.6	0698-5446
34.8	0757-0123
38.3	0698-3161

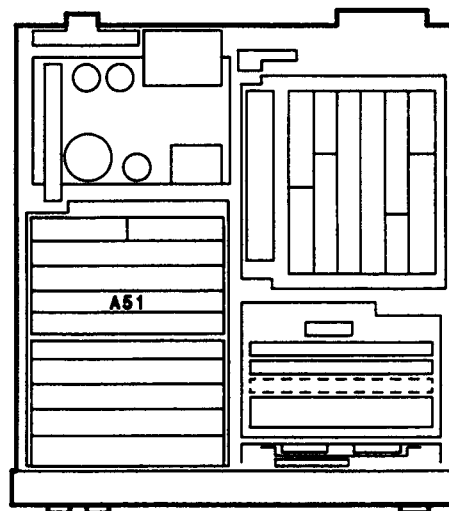

Adjustment 10—FM Sensitivity

Reference

Service Sheet 11.

Description

The FM sensitivity is adjusted for a calibration factor of 100% while the Measuring Receiver measures the output of its FM calibrator.

Procedure

1. Perform *Adjustment 9—FM Calibrator*.
2. Connect the CALIBRATION AM/FM OUTPUT to the INPUT. (The CALIBRATION AM/FM OUTPUT can be connected either to a sensor module or directly to the Measuring Receiver's INPUT.)

NOTE

For best accuracy, allow the Measuring Receiver to warm up for at least one-half hour.

3. Press FM then CALIBRATE. Allow at least two readings (approximately 40 seconds) to pass, then adjust A4R50 (FM SENS) for a display of 99.95 to 100.05%.

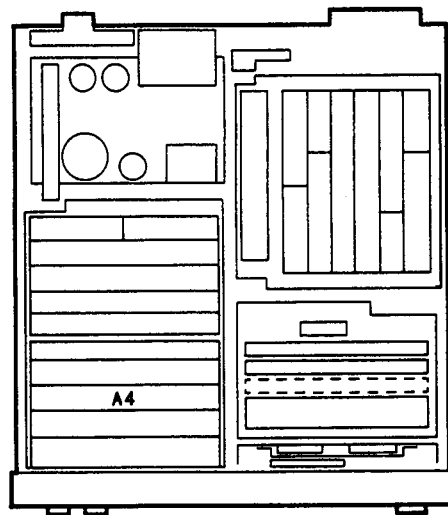

Adjustment 11—FM Flatness

Reference

Service Sheet 11.

Description

The AM/FM test source is frequency modulated at a 1 kHz rate with 400 kHz peak deviation. The demodulated FM is used as a reference. The modulation rate is increased to 150 kHz and the FM flatness is adjusted to bring the display back to the reference. The AM/FM test source is required to assure that the FM source has adequate bandwidth.

Equipment

AM/FM Test Source HP 11715A
 Audio Synthesizer HP 3336C

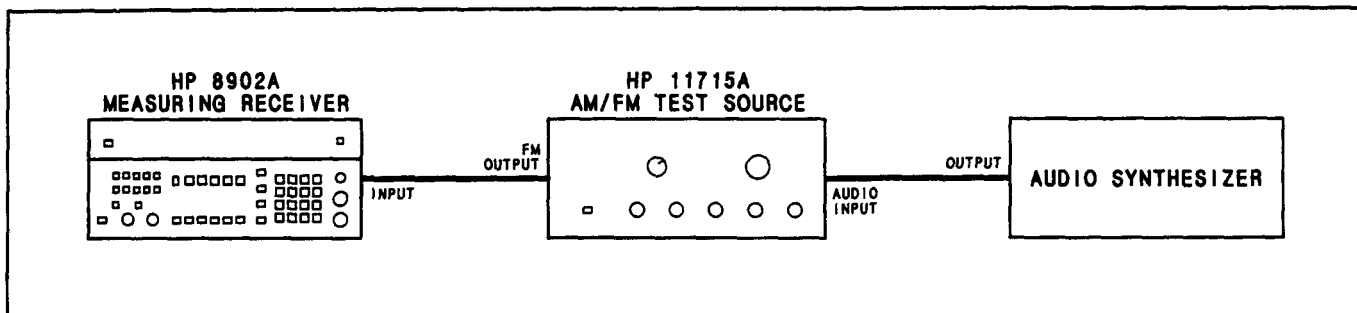
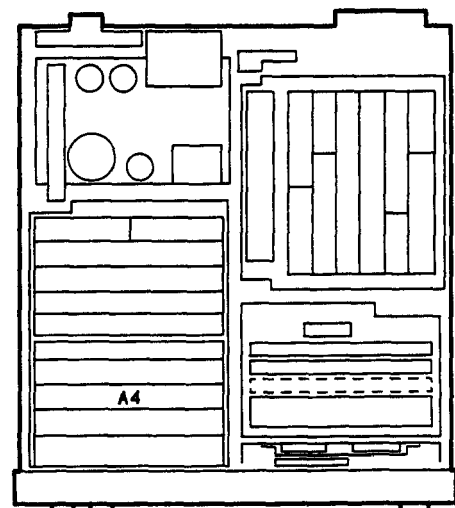

Figure 5-4. FM Flatness Adjustment Test Setup

Procedure

1. Connect the equipment as shown in Figure 5-4 using a short cable, approximately 0.3 meters (1 foot), to connect the audio synthesizer. (The AM/FM test source can be connected either to a sensor module or directly to the Measuring Receiver's INPUT.)
2. With the leveling on, set the audio synthesizer to 1 kHz at +5 dBm. On the AM/FM test source, set the test mode to FM.
3. On the Measuring Receiver, press the blue key then press INSTR PRESET (the AUTOMATIC OPERATION key) to preset the instrument.
4. Tune the AM/FM test source's carrier frequency to approximately 400 MHz.
5. On the Measuring Receiver, press MHz to center its tuning. Press FM. Set DETECTOR to AVG. Adjust the audio synthesizer level for a display of approximately 280 kHz average deviation. Set RATIO on (with LOG/LIN set for a linear display).



6. Set the audio synthesizer frequency to 150 kHz without changing the level. Adjust A4R85 (FM FLATNESS) for a reading of 99.9 to 100.1% REL on the Measuring Receiver.

NOTE

If flatness does not adjust properly, try performing Adjustment 12—FM Distortion and Incidental AM—1.5 MHz IF.

Adjustment 12—FM Distortion and Incidental AM—1.5 MHz IF

Reference

Service Sheet 5.

Description

The AM/FM test source is frequency modulated at a 100 kHz rate with 400 kHz peak deviation. The peak deviation is measured with both the positive and negative peak detectors when the Measuring Receiver is tuned first to the signal and then to its image. The IF is adjusted so that the difference between the detector readings is the same for both signals. This method permits proper adjustment of distortion even in the presence of a small amount of distortion from the FM source. The incidental AM is measured on an FM signal modulated at a 1 kHz rate and 50 kHz peak deviation. The instrument is adjusted for minimum AM.

Equipment

AM/FM Test Source HP 11715A
 Audio Analyzer HP 8903B

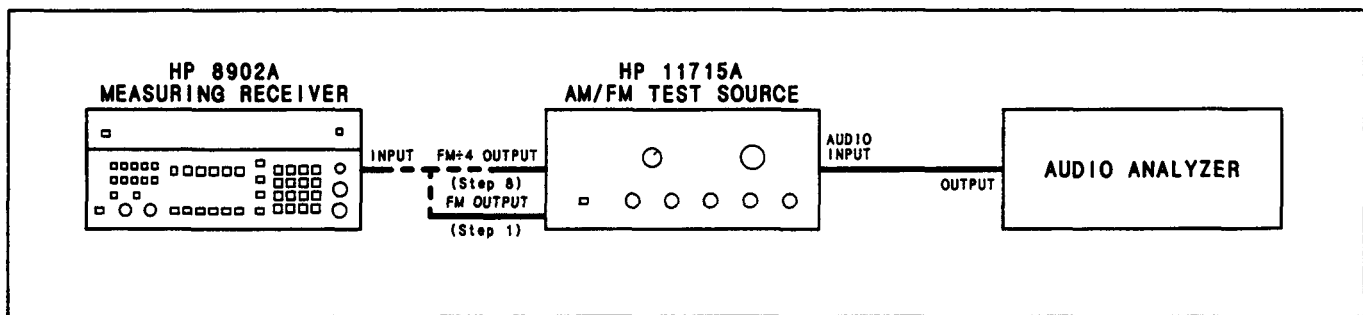

Figure 5-5. FM Distortion and Incidental AM—1.5 MHz Adjustment IF Test Setup

Procedure

1. Connect the equipment as shown in Figure 5-5. (The AM/FM test source output can be connected either to a sensor module or directly to the Measuring Receiver's INPUT.)
2. Set the audio analyzer's oscillator to 100 kHz at 4V. On the AM/FM test source, set the test mode to FM.
3. On the Measuring Receiver, press the blue key then press INSTR PRESET (the AUTOMATIC OPERATION key) to preset the instrument. Set the HP FILTER to 50 Hz.
4. Tune the AM/FM test source's carrier frequency to approximately 400 MHz.
5. On the Measuring Receiver, press MHz to center its tuning. Press FM. Adjust the audio analyzer's oscillator level for a display of 400 kHz peak deviation on the Measuring Receiver.
6. On the Measuring Receiver, switch the DETECTOR between PEAK+ and PEAK- and note the difference between the two readings. Adjust A18R23 (FM DISTN 1.5 MHZ IF) for equal readings between PEAK+ and PEAK-.
7. On the Measuring Receiver, key in 3000 ↓ kHz to tune the Measuring Receiver to the signal image. Again switch between PEAK+ and PEAK-. The difference between the two readings should be less than 1.6 kHz. If it is not, adjust A18R23 again to diminish the difference by one half. Now note the reading for PEAK+ (PK1+) and PEAK- (PK1-). Press ↑ kHz. Note the reading for PEAK+ (PK2+) and PEAK- (PK2-). The instrument is adjusted properly when

$$|(PK1+ - PK1-) + (PK2+ - PK2-)| < 1.6 \text{ kHz.}$$

(Ideally, PK1+ should equal PK2-, and PK1- should equal PK2+.)

8. Connect the FM÷4 output of the AM/FM test source to the Measuring Receiver's INPUT.
9. On the Measuring Receiver, set LP FILTER to 3 kHz. Press AUTOMATIC OPERATION.
10. Set the audio analyzer's oscillator frequency to 1 kHz and level for a display of 50 kHz deviation on the Measuring Receiver.
11. On the Measuring Receiver, press AM. Adjust A18R19 (INC AM 1.5 MHZ IF) for a minimum display (but less than 0.2%).

NOTE

The specification for incidental AM requires that 0.5 times the residual AM be subtracted out. The residual FM can be measured by momentarily disconnecting the audio input to the AM/FM test source and noting the displayed AM. Subtracting 0.5 times the displayed AM from the AM measurement in step 11 gives the actual incidental AM.

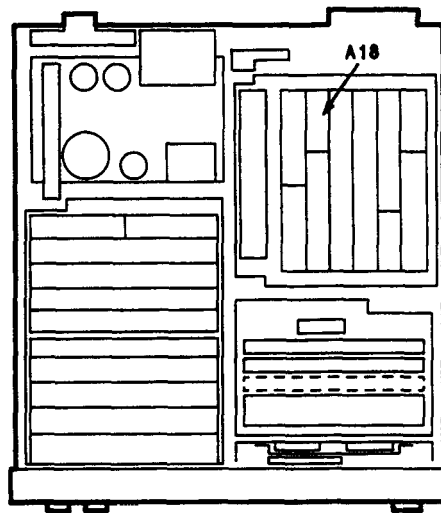

Adjustment 13— Φ M SENSITIVITY

Reference

Service Sheet 13.

Description

The AM/FM test source is frequency modulated with a sinusoidal signal at a 1 kHz rate and with 100 kHz peak deviation. This is equivalent to 100 rad peak deviation since

$$\text{phase deviation} = \frac{\text{frequency deviation}}{\text{modulation rate}}$$

The Φ M sensitivity is adjusted for a reading of 100 rad.

Equipment

AM/FM Test Source HP 11715A
 Audio Synthesizer HP 3336C

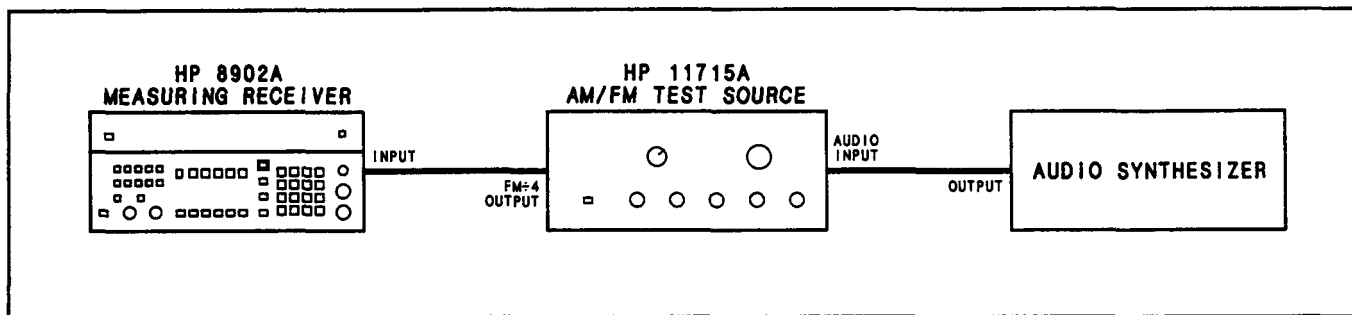
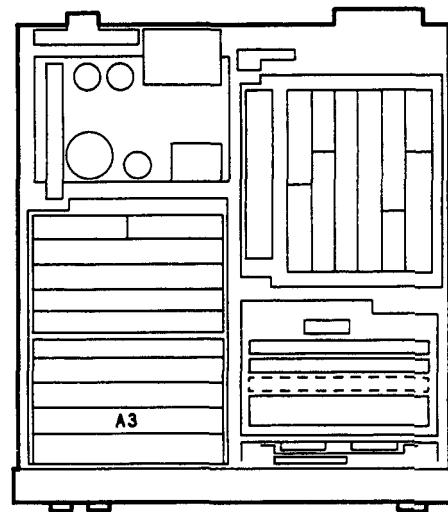

Figure 5-6. Φ M Sensitivity Adjustment Test Setup

Procedure

1. Connect the equipment as shown in Figure 5-6. (The AM/FM test source output can be connected either to a sensor module or directly to the Measuring Receiver's INPUT.)
2. Set the audio synthesizer to 1 kHz at +4 dBm. On the AM/FM test source, set the test mode to FM.
3. On the Measuring Receiver, press the blue key then press INSTR PRESET (the AUTOMATIC OPERATION key) to preset the instrument. Set HP FILTER to 300 Hz and LP FILTER to 3 kHz.
4. Tune the AM/FM test source's carrier frequency to approximately 100 MHz.
5. On the Measuring Receiver, press the MHz key to center its tuning. Press FM. Adjust the audio synthesizer for a display of 100 kHz on the Measuring Receiver.



6. On the Measuring Receiver, press Φ M. Adjust A3R27 (Φ M SENS) for a display of the same numerical value as the display in kHz of step 5 \pm 0.2 rad.

NOTE

If a test oscillator is used in place of the audio synthesizer, the modulation rate must be measured with a counter (or simply key in S (Shift) AUDIO FREQ). The adjustment is then made to give a display equal to the ratio (frequency deviation)/(modulation rate).

Adjustment 14—AM Calibrator

Reference

Service Sheet 30.

Description

The Measuring Receiver is set to read %AM as computed from internal measurements. The AM depth is adjusted for 33.33%. The AM is then demodulated and the symmetry is adjusted as the signal is measured with the peak+ and peak- detectors.

NOTE

This calibration adjustment is not critical. Built-in safeguards minimize the possibility of erroneous calibration. If conditions exist that are out of calibration, the Measuring Receiver displays an error message.

Procedure

1. Connect CALIBRATION AM/FM OUTPUT to INPUT. (The CALIBRATION AM/FM OUTPUT can be connected either to a sensor module or directly to the Measuring Receiver's INPUT.)
2. Key in 13.0 SPCL. This sets the instrument to display the AM computed from internal measurements.
3. Adjust A50R45 ("A" LVL) for a display of 33.330 to 33.336%.
4. Key in 49.5 SPCL. This Connects the internal voltmeter to measure the output level from the AM calibrator. The display should read between 1.8 and 2.2.
5. Key in 13.2 SPCL then 5.1 SPCL. This sets the instrument to display the demodulated AM from the calibrator and sets the peak detector time constant to slow.
6. Alternately set the DETECTOR to PEAK+ and PEAK- and note the display for each setting. Adjust A50R39 (SYMM) until the readings are the same for both detectors within $\pm 0.015\%$.

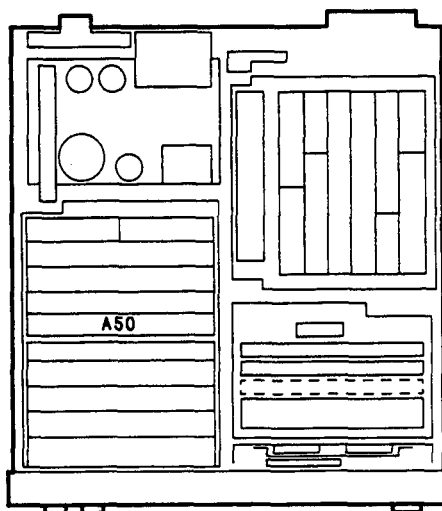

Adjustment 15—AM Sensitivity

REFERENCE

Service Sheet 12.

DESCRIPTION

The AM sensitivity is adjusted for a calibration factor of 100% while the Measuring Receiver measures the output of its AM calibrator.

PROCEDURE

1. Perform *Adjustment 14—AM Calibrator*.
2. Connect the CALIBRATION AM/FM OUTPUT to the INPUT. (The CALIBRATION AM/FM OUTPUT can be connected either to a sensor module or directly to the Measuring Receiver's INPUT.)

NOTE

For best accuracy, allow the Measuring Receiver to warm up for at least one-half hour.

3. Press AM then CALIBRATE. Allow at least two readings (approximately 40 seconds) to pass, then adjust A2R6 (AM SENS) for a display of 99.95 to 100.05%.

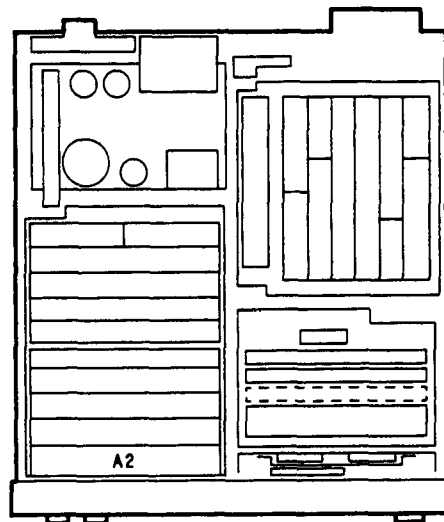

Adjustment 16—FM Distortion and Incidental AM—455 kHz IF

Reference

Service Sheets 5 and 8.

Description

The signal generator is set to 2.45 MHz and frequency modulated at a 1 kHz rate with 10 kHz peak deviation. The incidental AM on the signal is measured and the instrument is adjusted for minimum AM. At 2.45 MHz the signal is not down converted by the Measuring Receiver but goes directly into the IF. The adjustment alters the rolloff characteristic of a 2.5 MHz IF low-pass filter, which is the principal source of the incidental AM.

For the 455 kHz IF, the AM/FM test source is frequency modulated at a 10 kHz rate with 10 kHz peak deviation. The demodulated FM is measured with a distortion analyzer and FM distortion is adjusted for a minimum. The incidental AM is measured with FM set for a 1 kHz rate and 5 kHz peak deviation. The instrument is adjusted for minimum AM.

Equipment

AM/FM Test Source	HP 11715A
Audio Analyzer	HP 8903B
Signal Generator	HP 8640B

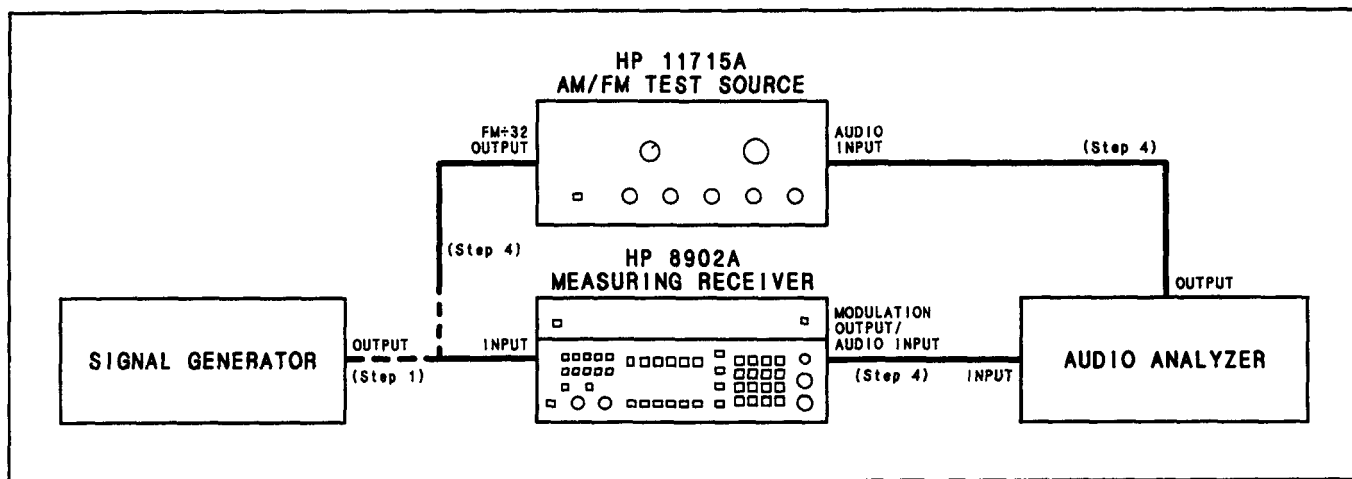

Figure 5-7. FM Distortion and Incidental AM—455 kHz IF Adjustment Test Setup

Procedure

NOTE

In the following procedure the RF modulation source can be connected either to a sensor module (which is connected to the Measuring Receiver) or directly to the Measuring Receiver's INPUT connector. The procedure is written for the latter case.

1. Set the signal generator to 2.45 MHz at 0 dBm with 10 kHz peak FM deviation at a 1 kHz rate. Connect its RF output to the Measuring Receiver's INPUT as shown in Figure 5-7.
2. On the Measuring Receiver, press the blue key and then press INSTR PRESET (the AUTOMATIC OPERATION key) to preset the instrument. Key in 34.0 SPCL to measure the IF

frequency. The IF should be approximately 2.45 MHz. If it reads approximately 0.455 MHz, tune the frequency down slightly until a reading of 2.45 MHz is obtained.

3. On the Measuring Receiver, press AM. Set HP FILTER to 50 Hz, LP FILTER to 3 kHz, and DETECTOR to AVG. Adjust A6C8 (IF FLATNESS) for a minimum display (but less than 0.2%).
4. Disconnect the signal generator and connect the remaining equipment as shown in Figure 5-7.
5. Set the audio analyzer's oscillator to 10 kHz at 4V. On the AM/FM test source, set the test mode to FM.
6. On the Measuring Receiver, press FREQ. Tune the AM/FM test source's carrier frequency to approximately 12.5 MHz.
7. On the Measuring Receiver, key in 3.1 SPCL to set the IF to 455 kHz, press FM, and set LP FILTER to >20 kHz and DETECTOR to PEAK+.
8. Adjust the audio analyzer's oscillator level for a Measuring Receiver display of 10 kHz peak deviation.
9. Set the distortion analyzer (in the audio analyzer) to measure the distortion on the 10 kHz signal at the MODULATION OUTPUT/AUDIO INPUT with 30 kHz of low-pass filtering on the distortion analyzer.
10. Adjust A17L11 (FM DISTN 455 KHZ IF) for minimum distortion but less than 0.1% (less than -60 dB).
11. On the Measuring Receiver, set LP FILTER to 3 kHz.
12. Set the audio analyzer's oscillator frequency to 1 kHz and level for 5 kHz peak deviation on the Measuring Receiver.
13. On the Measuring Receiver, press AM. Adjust A17L8 (INC AM 455 KHZ IF) for a minimum display (but less than 0.2%).

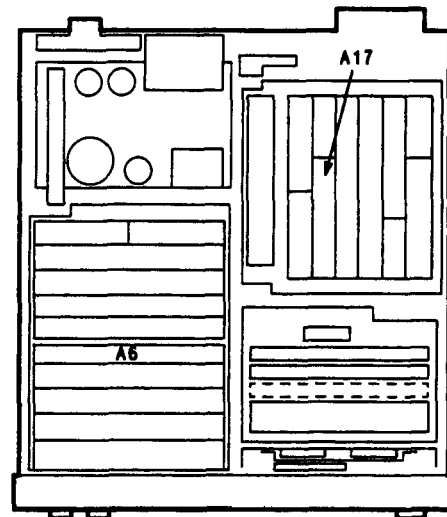

NOTE

The specification for incidental AM requires that 0.5 times the residual AM be subtracted out. The residual AM can be measured by momentarily disconnecting the audio input to the AM/FM test source and noting the displayed AM on the Measuring Receiver. Subtracting 0.5 times the displayed AM from the AM measured in step 14 gives the actual incidental AM.

14. If a significant adjustment was made in either step 10 or step 13, repeat steps 5 through 14.

Adjustment 17—Track-Tune Mode Offset

REFERENCE

Service Sheet 20.

DESCRIPTION (2305A TO 2529A)

The Measuring Receiver is tuned to a signal and put in the track-tune mode. The frequency of the IF is measured and the offset is adjusted to bring the frequency to within ± 20 kHz of 1.5 MHz.

DESCRIPTION (2530A AND ABOVE)

The Measuring Receiver is tuned to a signal and put in the track-tune mode with a 455 kHz IF. The frequency of the IF is measured and the offset is adjusted to bring the frequency to within ± 500 Hz of 455 kHz.

PROCEDURE (2305A TO 2529A)

1. Connect the CALIBRATION RF POWER OUTPUT to the INPUT. (The CALIBRATION RF POWER OUTPUT can be connected either to a sensor module or directly to the Measuring Receiver's INPUT.)
2. Press the blue key then press INSTR PRESET (the AUTOMATIC OPERATION key) to preset the instrument. Key in 45.16 SPCL to turn on the RF power calibrator. (This provides a signal for the Measuring Receiver's input.)
3. Key in 34.0 SPCL to set the instrument to measure the IF frequency. Press TRACK MODE.
4. Adjust A20R1 (TRK OFS) for a display between 1.480 and 1.520 MHz.

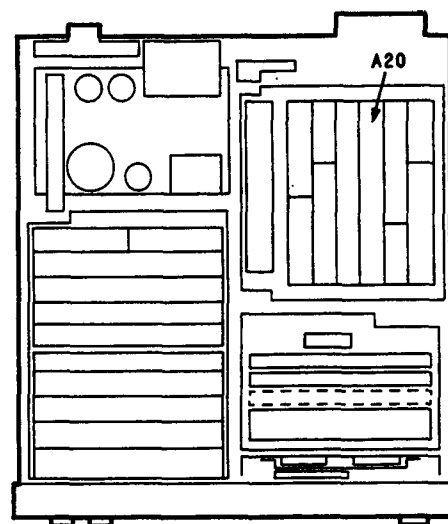

PROCEDURE (2530A AND ABOVE)

1. Connect the CALIBRATION RF POWER OUTPUT to the INPUT. (The CALIBRATION RF POWER OUTPUT can be connected either to a sensor module or directly to the Measuring Receiver's INPUT.)
2. Press the blue key then press INSTR PRESET (the AUTOMATIC OPERATION key) to preset the instrument. Key in 45.16 SPCL to turn on the RF power calibrator. (This provides a signal for the Measuring Receiver's input.)
3. Press MHz. Press TRACK MODE. Key in 0.072 SPCL. (This puts the Measuring Receiver in the 455 kHz IF, manual track-tune mode.) Key in 46.1 SPCL to set the instrument to measure the IF frequency.
4. Adjust A20R1 (TRK OFS) for a display between 45450 and 45550.

Adjustment 18—Power Reference (Using Reference Comparison)

Reference

Service Sheet 3.

Description

The frequency of the internal power reference is checked and adjusted, if necessary, to 50 MHz. The power from an external 1 mW power reference is measured with a power sensor and the power meter of the Measuring Receiver. The same power sensor and power meter are then used to measure the power from the Measuring Receiver's power reference. The Measuring Receiver's power reference is adjusted to give the same reading as for the external power reference.

NOTE

After adjustment, the accuracy of the Measuring Receiver's power reference will be $\pm 1.2\%$. Greater accuracy can be obtained by using a recently calibrated external power reference or by following the procedure in Adjustment 19—Power Reference (Using DC Substitution).

Equipment

Power Reference	HP 435A Opt K05
Sensor Module	HP 11722A

Procedure

1. Connect the sensor module's cables to the SENSOR and INPUT of the Measuring Receiver. Connect the sensor module's input to the CALIRATION RF POWER OUTPUT. (If a sensor module is not available, connect the Measuring Receiver's INPUT directly to the CALIBRATION RF POWER OUTPUT.)
2. On the Measuring Receiver, press the blue key then press INSTR PRESET (the AUTOMATIC OPERATION key) to preset the instrument. Key in 45.16 SPCL to turn on the RF power calibrator. Press TRACK MODE. The Measuring Receiver's display should read between 49.5 and 50.5 MHz.
3. If the frequency of the RF power calibrator is not within the proper limits, remove the thumb screw retaining the A32 Power Reference Oscillator and slide the assembly out. Adjust A32L1 for a frequency reading between 49.5 and 50.5 MHz. (The adjustment is accessed through a hole on the back side of the assembly.)



After removing the RF power calibrator assembly, take care that the power supply terminals do not short against the metal chassis parts.

NOTE

If the frequency of the power reference is already within the proper limits, do not attempt to adjust the frequency to exactly 50 MHz. To do so may unnecessarily affect the level.

4. Reinstall the A32 assembly. (The thumb screw need only be finger tight.)
5. Connect the input of the sensor module (or a compatible power sensor connected to the Measuring Receiver's SENSOR input) to the output of the external power reference.
6. On the Measuring Receiver, press ZERO and wait for the power sensor to zero.
7. On the Measuring Receiver, press RF POWER. Press RATIO and check that LOG/LIN is in the linear mode. (The display should read between 99.9 and 100.1% REL.)
8. Connect the sensor module to the CALIBRATION RF POWER OUTPUT of the Measuring Receiver. Press ZERO and allow the instrument to zero. Adjust A32R4 (LEVEL ADJ) for a reading between 99.9 and 100.1% REL. If the adjustment runs out of range, replace A32R5 with 7500Ω and readjust A32R4.

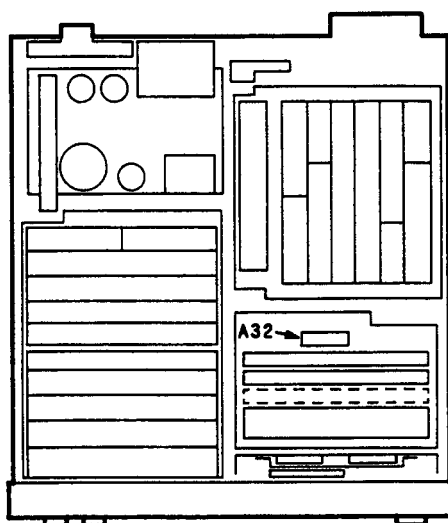

Adjustment 19—Power Reference (Using DC Substitution)

Reference

Service Sheet 3.

Description

The frequency of the internal power reference is checked and adjusted, if necessary, to 50 MHz. The power from the power reference oscillator is measured by a method known as dc substitution. In this method a power-sensing thermistor is placed in one arm of a self-balancing, dc resistance bridge. With no power applied, the dc voltage supplying the top of the bridge is automatically adjusted until the thermistor heats to the temperature that produces the resistance required to bring the bridge into balance. When RF power is applied to the thermistor, the thermistor heats up and momentarily unbalances the bridge. The self-balancing circuits then readjust the supply voltage to the bridge to re-balance it. A second bridge, which senses only the ambient temperature, is employed to compensate for measurement drift. Careful measurement of the bridge dc voltages provides a way to determine the amount of RF power applied to the thermistor to a higher degree of accuracy than can be obtained by direct reading of the power meter.

NOTE

After adjustment, the accuracy of the Measuring Receiver's power reference will be $\pm 0.7\%$. A simpler, but less accurate method for adjusting the power reference can be found in Adjustment 18—Power Reference (Using Reference Comparison).

Equipment

Digital Voltmeter	HP 3455A
Power Meter	HP 432A
Thermistor Mount	HP 478A Opt H75

Procedure

1. On the Measuring Receiver, connect the CALIBRATION RF POWER OUTPUT to the INPUT. (If a sensor module is being used, connect its input to the CALIBRATION RF POWER OUTPUT.)
2. On the Measuring Receiver, press the blue key then press INSTR PRESET (the AUTOMATIC OPERATION key) to preset the instrument. Key in 45.16 SPCL to turn on the RF power calibrator. Press TRACK MODE. The Measuring Receiver's display should read between 49.5 and 50.5 MHz.
3. If the frequency of the RF power calibrator is not within the proper limits, remove the thumb screw retaining the A32 Power Reference Oscillator and slide the assembly out. Adjust A32L1 for a frequency reading between 49.5 and 50.5 MHz. (The adjustment is accessed through a hole on the back side of the assembly.)

CAUTION

After removing the RF power calibrator assembly, take care that the power supply terminals do not short against the metal chassis parts.

NOTE

If the frequency of the power reference is already within the proper limits, do not attempt to adjust the frequency to exactly 50 MHz. To do so may unnecessarily affect the level.

4. Reinstall the A32 assembly. (The thumb screw need only be finger tight.)
5. With the HP 432A Power Meter switched off and the thermistor interconnect cable connected to it but not to the thermistor mount, measure the resistance between the center conductor of the rear-panel VRF connector and pin 1 (the first pin to the right of the key slot) on the thermistor end of the interconnect cable. Record the value of the mount resistance for future reference. (It should be approximately 200Ω.)

Mount Resistance (R): _____ Ω

6. Connect the equipment as shown in Figure 5-8. The input of the digital voltmeter should be floating. The positive input of the voltmeter should be connected to the rear-panel VCOMP connector of the HP 432A Power Meter, the negative input to the VRF connector. Switch the equipment on and let it warm up for at least 30 minutes.

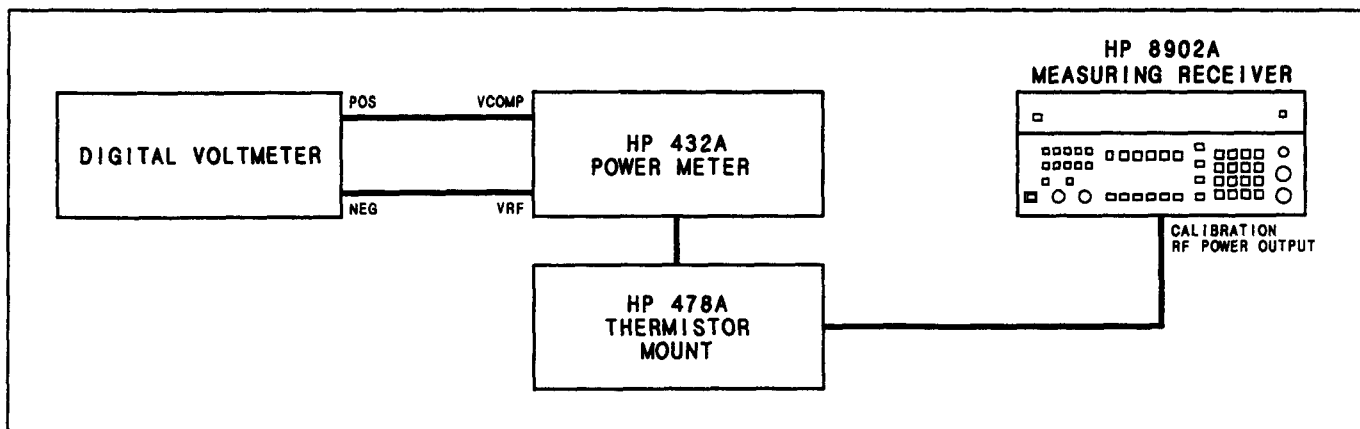
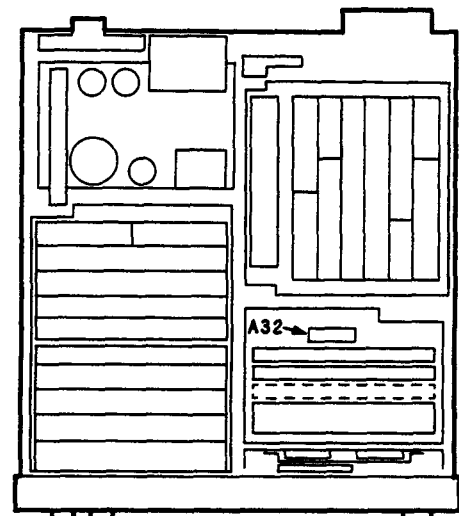

Figure 5-8. Power Reference Adjustment Test Setup

7. On the Measuring Receiver, key in 45.0 SPCL to switch the power reference off.
8. Set the HP 432A Power Meter RANGE to COARSE ZERO and adjust the front-panel COARSE ZERO to obtain a zero meter indication.
9. Fine zero the HP 432A Power Meter on the most sensitive range, then set the RANGE switch to 1 mW (0 dBm).

10. Observe the voltage reading on the voltmeter. If the reading is greater than 400 μV , press and hold the FINE ZERO switch on the HP 432A Power Meter and adjust COARSE ZERO so that the voltmeter reads less than 200 μV then release the FINE ZERO switch. Record the voltmeter reading.

$V_{COMP} - V_{RF}$ with No Power (V_0): _____ Vdc

11. Connect the voltmeter to read V_{COMP} (with respect to chassis ground) on the HP 432A Power Meter. (The voltmeter's negative input should connect to chassis ground.)
12. On the Measuring Receiver, key in 45.16 SPCL. Record the voltmeter reading.

V_{COMP} with 1 mW: _____ Vdc

13. Reconnect the voltmeter leads as shown in Figure 5-8 (where VRF is connected to the negative input of the voltmeter).
14. The voltmeter is now set up to measure V_1 which represents the reference output level. Compute the desired value of V_1 (for 1 mW) from the equation

$$V_1 = V_{COMP} - \sqrt{(V_{COMP} - V_0)^2 - 0.004RH}$$

where H is the effective efficiency of the thermistor mount at 50 MHz as read from the mount's label.

Desired V_1 : _____ Vdc

15. Adjust A32R4 (LEVEL ADJ) until the voltmeter reading is the same as V_1 computed in step 14. If the adjustment runs out of range, replace A32R5 with 7100 Ω and readjust A32R4.

Adjustment 20—Power Meter

Reference

Service Sheet 1.

Description

The frequency of the 220 Hz multivibrator is adjusted for a maximum power reading of a nominal input signal. This occurs when the phase shift through the ac amplifier chain of the power meter is zero. Two linearity adjustments are then made on the two highest power ranges using a power meter range calibrator.

Equipment

Extender Cable HP 08901-60179
 Range Calibrator HP 11683A

Procedure

1. Connect the power meter output of the range calibrator to the Measuring Receiver's SENSOR input.
2. On the range calibrator, set the function to calibrate, polarity to normal, and range to 1 mW.
3. On the Measuring Receiver, press RF POWER. Adjust A53R40 (FREQ) for a maximum reading on the Measuring Receiver's display (approximately 1 mW).
4. On the Measuring Receiver, press S (Shift) AUDIO FREQ. Set AUDIO INPUT to read external.
5. On the Measuring Receiver, connect the MODULATION OUTPUT/AUDIO INPUT to A53TP4 (MLTVIB). The Measuring Receiver's display should read between 204 and 236 Hz.
6. Remove the cable from A53TP4.
7. On the range calibrator, set the function to standby.
8. On the Measuring Receiver, press RF POWER. Press ZERO and wait for the instrument to zero.
9. On the range calibrator, set the function to calibrate.
10. On the Measuring Receiver, press CALIBRATE then press the blue key then press SAVE CAL (again, the CALIBRATE key). This normalizes the power reading to 1 mW. (The CALIBRATE key light should be on.)
11. On the Measuring Receiver, key in 10.4 SPCL to set the power meter to range 4.
12. Set the range calibrator range to 10 mW. The Measuring Receiver's display should read between 9.99 and 10.01 mW. If it does not, perform the following steps.
 - a. Switch the Measuring Receiver off and extend the A53 RF Power Assembly.
 - b. Connect the extender cable to the RF Power Assembly. Connect the range calibrator to the sensor connector on the extender cable.
 - c. Switch the Measuring Receiver back on. Repeat steps 7 to 12.
 - d. Adjust A53R13 (RNG 4) for a Measuring Receiver display of 10.00 mW.

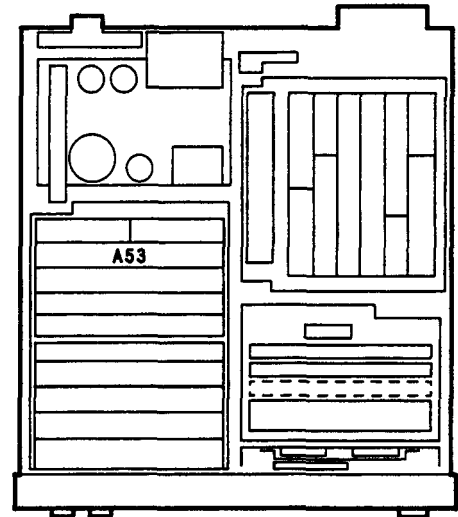

13. On the Measuring Receiver, key in 10.5 SPCL to set the power meter to range 5.
14. Set the range calibrator range to 100 mW. The Measuring Receiver's display should read between 99.9 and 100.1 mW. If it does not, perform the following steps.
 - a. If the A53 RF Power Assembly is already extended, go to step e.
 - b. Switch the Measuring Receiver off and extend the A53 RF Power Assembly.
 - c. Connect the extender cable to the RF Power Assembly. Connect the range calibrator to the sensor connector on the extender cable.
 - d. Switch the Measuring Receiver off and extend the A53 RF Power Assembly. (Reconnect the two cables on the top of the assembly.)
 - e. Switch the Measuring Receiver back on. Repeat steps 7 to 14.
- d. Adjust A53R16 (RNG 5) for a Measuring Receiver display of 100.0 mW.

Adjustment 21—Audio True RMS Detector and Notch Filter Gain

Reference

Service Sheet 16.

Description

The offset of the audio true rms detector is first adjusted to read zero with no audio input, then a signal of known level is applied to the detector and the sensitivity of the detector is adjusted to read the correct level. The gain of the audio notch filter is adjusted for a reading of 100% with an input signal that is twice the frequency of the notch filter.

Equipment

Audio Oscillator HP 8903B
 Digital Voltmeter HP 3455A

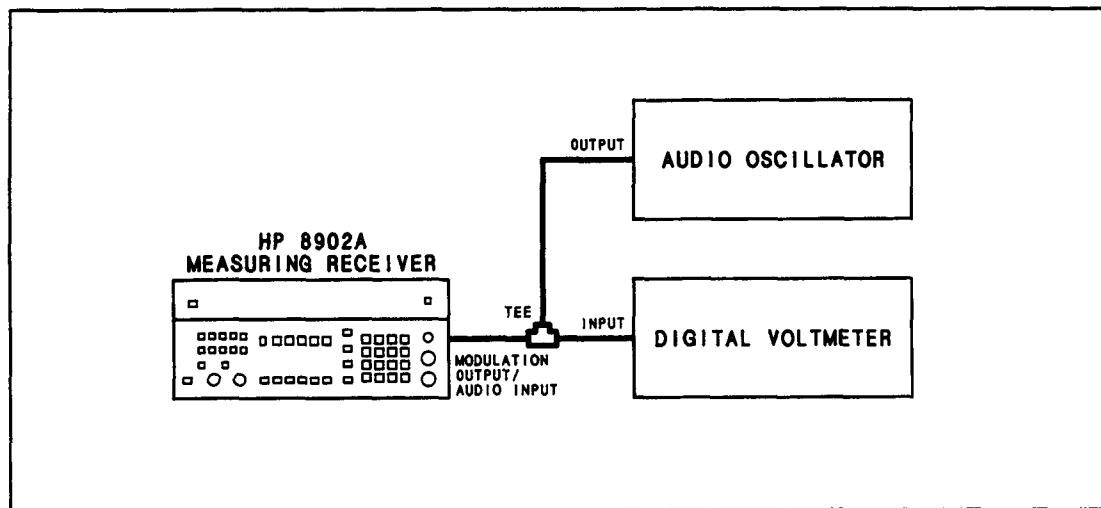
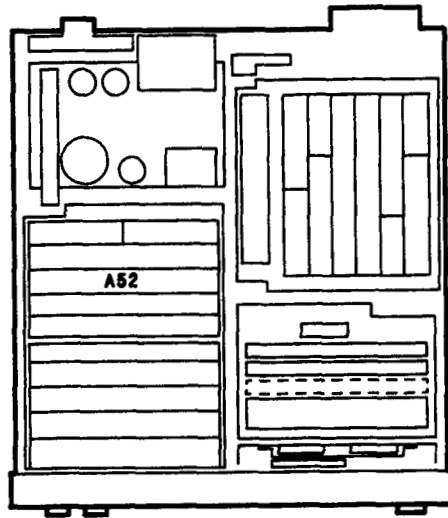

Figure 5-9. Audio True RMS Detector and Notch Filter Gain Adjustment Test Setup

Procedure

1. Remove any cable from the MODULATION OUTPUT/AUDIO INPUT connector of the Measuring Receiver.
2. On the Measuring Receiver, press the blue key then press INSTR PRESET (the AUTOMATIC OPERATION key) to preset the instrument. Key in 30.0 SPCL to set the instrument to measure and display the voltage at the MODULATION OUTPUT/AUDIO INPUT connector with the audio true rms detector. Key in 49.7 SPCL to measure and display the output of the audio true rms detector. (The displayed voltage will be ten times the level displayed with Special Function 30.)
3. Adjust A52R47 (RMS OFS) for a reading on the Measuring Receiver's display between -0.0005 and 0.0005 .
4. Key in 30.0 SPCL. The display should read 0.0000 V.
5. Connect the equipment as shown in Figure 5-9.
6. Set the audio oscillator for 3.9 V_{rms} into an open circuit at 2 kHz. Set the voltmeter to read ac volts.

7. Adjust A52R38 (RMS SENS) for a reading on the display of the Measuring Receiver that is the same as the reading on the voltmeter to the third decimal place. (The readings should be approximately 3.9 Vrms.)
8. Set the audio oscillator level to 100 mVrms.
9. On the Measuring Receiver, press S (Shift) AUDIO DISTN. Adjust A52R44 (NOTCH FLTR GAIN) for a display on the Measuring Receiver between 99.9 and 100.1%.
10. Set the audio oscillator frequency to 800 Hz.
11. On the Measuring Receiver, press the blue key then press 400 Hz DISTN (the PEAK- key). The Measuring Receiver's display should read greater than 98%.



Adjustment 22—Battery Backup

Reference

Service Sheet 24.

Description

The battery backup circuit switches the supply for the internal RAM to an internal battery when either the +12V or +5V supply drops. The two supplies are measured on the memory assembly and the voltage at which the backup switches is adjusted to a level based on the measured supply voltages.

Equipment

Digital Voltmeter HP 3455A

Procedure

1. Connect the voltmeter to A13TP10 (+5V). Measure and record the dc voltage with respect to ground.

Voltage at A13TP10 _____ Vdc

2. Connect the voltmeter to A13TP12 (+12V). Measure and record the dc voltage with respect to ground.

Voltage at A13TP12 _____ Vdc

3. Make the following calculations.

$\frac{2}{5} \times$ Voltage at A13TP10 = _____ Vdc

$\frac{1}{6} \times$ Voltage at A13TP12 = _____ Vdc

4. Make the following calculation.

$0.95 \times$ Lowest Voltage of Step 3 = _____ Vdc

5. Connect the voltmeter to A13TP11 (VR). Adjust A13R12 (VR) until the voltmeter reads within $\pm 0.05V$ of the voltage calculated in step 4.

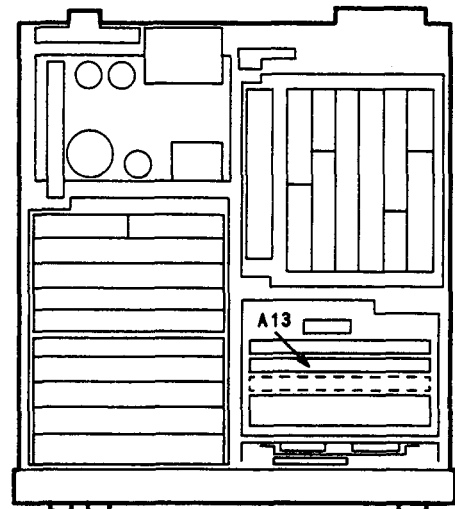

Adjustment 23—Narrow 455 kHz IF Filter

REFERENCE

Service Sheet 6.

DESCRIPTION

An x-y plot of the frequency response of the narrow 455 kHz IF filter is obtained by sweeping the IF with a signal generator and looking at the response on an oscilloscope with its x axis driven by the sweep output of the signal generator. The filter's overall response is checked and adjustments are made only if the filter is out of limits. The overall IF gain is also adjusted.

Adjustment of the filter begins by adjusting overall flatness and slope. If the adjustment is inadequate, then the first stage of the filter is observed as succeeding stages are shorted out and adjustments made to the filter components to bring about responses of a particular given shape.

EQUIPMENT

Divider Probe, 10:1	HP 10040A
Oscilloscope	HP 1740A
Signal Generator	HP 3336C
Adjustment Tool	8710-0772

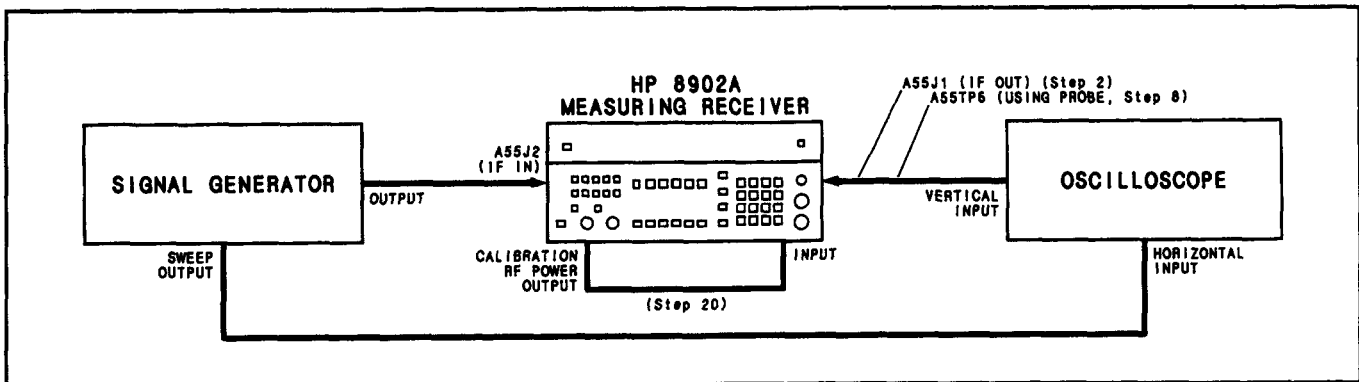
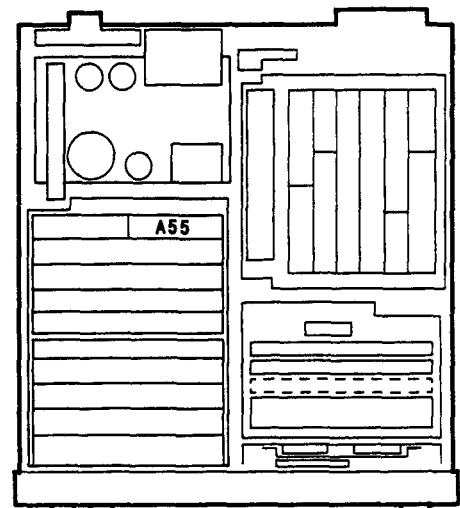

Figure 5-10. Narrow 455 kHz IF Filter Adjustment Test Setup

PROCEDURE

1. Perform Adjustment 16—FM Distortion and Incidental AM—455 kHz IF.
2. Connect the equipment as shown in Figure 5-10. (Connect the vertical input of the oscilloscope directly to A55J1 (IF OUT).)
3. Set the signal generator to 0 dBm and set its frequency to sweep from 430 to 480 kHz (that is, 455 ± 25 kHz).
4. On the Measuring Receiver, press the blue key then press INSTR PRESET (the AUTOMATIC OPERATION key) to preset the instrument. Key in 0.2 S (Shift) 26 SPCL and 0.2 S 30 SPCL to set the gain of the IF amplifiers to 0 dB and to insert the narrow 455 kHz IF filter.



5. Adjust the oscilloscope so that the swept IF response spans exactly ten horizontal divisions and eight vertical divisions then readjust the vertical position to bring the top of the waveform to a convenient graticule. (Set the signal generator sweep rate as slow as possible while obtaining a flicker-free display.)
6. On the Measuring Receiver, adjust A55C24 (FLTR SLOPE) and A55R48 (FLTR FLAT) for the flattest response. The filter response should appear as in Figure 5-11a. Pass-band ripple should be less than 0.1 division (2.5%) overall over the two center horizontal divisions (± 5 kHz centered about 455 kHz). The filter response should be down at least 1 division (25%) at ± 3 horizontal divisions (± 15 kHz) from the center. (Adjustment of A55C24 affects symmetry, A55R48 affects flatness and gain. Expand the vertical scale, if necessary, to see the passband ripple.)
7. If the filter response can be properly adjusted, continue on at step 19. Otherwise, turn the Measuring Receiver off. Remove the cables from the A55 IF Amplifier/Filter Assembly. Remove the shield cover from the assembly and extend the assembly.
8. Connect the equipment as shown in Figure 5-10. (Connect the vertical input of the oscilloscope to A55TP6 with a low-capacitance 10:1 divider probe.) Turn the Measuring Receiver back on.
9. On the Measuring Receiver, key in 0.2 S (Shift) 26 SPCL and 0.2 S 30 SPCL.
10. Short A55TP3 to A55TP2 (GND).
11. Increase the oscilloscope's vertical gain by a factor of ten. Adjust the positioning for a centered waveform.
12. Adjust A55L3 for a peak one division left of center (450 kHz). The response should appear as in Figure 5-11b.
13. Remove the short from A55TP3. Short A55TP5 to A55TP2. Adjust A55L4 for a dip 0.2 division left of center (454 kHz). The response should appear as in Figure 5-11c.
14. Remove the short from A55TP5. Short A55TP4 to A55TP2. Adjust A55L5 for a peak 0.2 division left of center. The response should appear as in Figure 5-11d.
15. Remove the short from A55TP4. Short A55TP1 to A55TP2. Adjust A55L6 for a dip 0.2 division left of center. The response should appear as in Figure 5-11e.
16. Remove the short from A55TP1. Adjust A55L7 for a dip 0.2 division left of center. The response should appear as in Figure 5-11f.
17. Turn the Measuring Receiver off. Re-install the shield cover on the A55 assembly and insert the assembly into its extrusion.
18. Reconnect the equipment as in step 2. Turn the Measuring Receiver back on. Repeat steps 4 through 7.
19. Disconnect the oscilloscope from A55J1 and the signal generator from A22J2. Reconnect the internal innerconnect cables to A55J1 and A55J2.
20. On the Measuring Receiver, connect CALIBRATION RF POWER OUTPUT to INPUT. See Figure 5-10.
21. On the Measuring Receiver, press the blue key then INSTR PRESET. Key in 45.16 SPCL to turn on the RF power calibrator. Let the Measuring Receiver tune, then key in 3.5 SPCL to select the narrow 455 kHz IF filter. Press MHz to manually tune the instrument to the input signal. Key in S (shift) IF LEVEL. The display should indicate approximately 100%.
22. Key in 6.2 SPCL to open the AM ALC loop to permit measurement of IF level. Key in 1.3 SPCL to insert 20 dB of RF attenuation. The display should read between 50 and 200%.

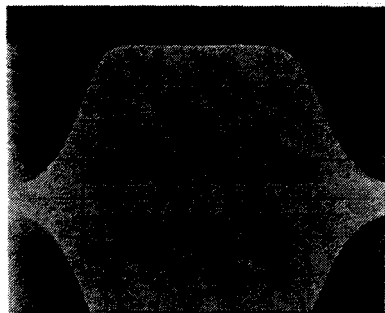

a. Oscilloscope Display for Step 6

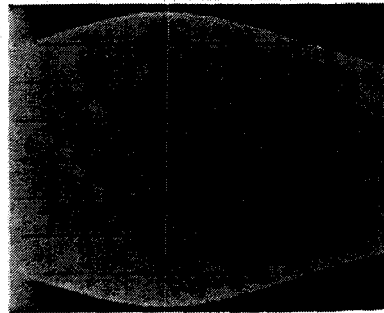

b. Oscilloscope Display for Step 12

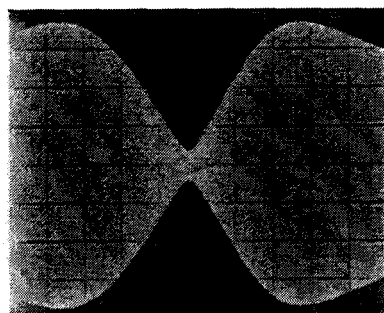

c. Oscilloscope Display for Step 13

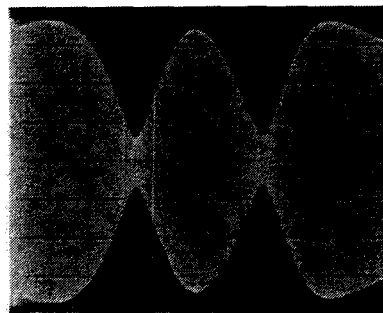

d. Oscilloscope Display for Step 14

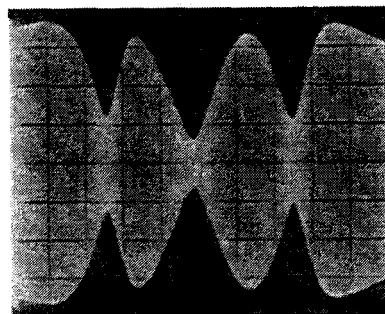

e. Oscilloscope Display for Step 15

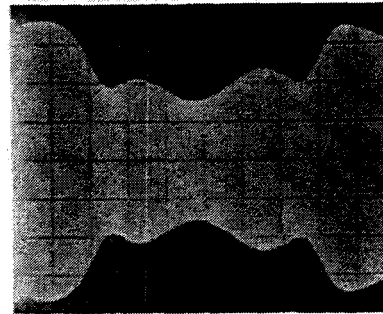

f. Oscilloscope Display for Step 16

Figure 5-11. *Narrow 455 kHz IF Filter Adjustment Oscilloscope Displays*

23. Press RATIO and LOG/LIN to set a reference of 0 dB. Key in 3.1 SPCL to remove the narrow 455 kHz IF filter. Adjust A55R33 (AMPL GAIN) for a display of 0.00 dB REL.
24. Press RANGE HOLD. Connect the white/green/violet (957) cable that normally connects to A55J2 (IF IN) to A54J2 (IF IN). (This bypasses the A55 IF Amplifier/Filter Assembly and establishes an input reference for measuring the gain of the A55 assembly.)

25. Press **RATIO** twice to establish a new reference. Reconnect the white/green/violet cable back to A55J2 and reconnect the white/brown/green cable (915) back to A54J2.
26. Adjust A55R38 (IF GAIN) for a display of 0.00 dB REL.

Adjustment 24—IF Synchronous Detector

Reference

Service Sheet 7.

Description

The pretune frequency is adjusted for 457 kHz. The pretune voltage is removed, and the phase detector offset voltage is adjusted for no frequency drift. By means of comparing the peaks of the 455 kHz VCO drive signal to the zero crossings of the VCO drive to the synchronous detector, the relative phase shift is adjusted for 90°. The synchronous detector offset is adjusted for 0 Vdc with no input signal. A resistor in the gain-determining DAC of the phase lock loop is selected to give a pre-determined lock bandwidth.

Equipment

Divider Probe, 10:1 (2 required)	HP 10040A
Oscilloscope	HP 1740A
Gain/Phase Meter (Optional)	HP 3575A

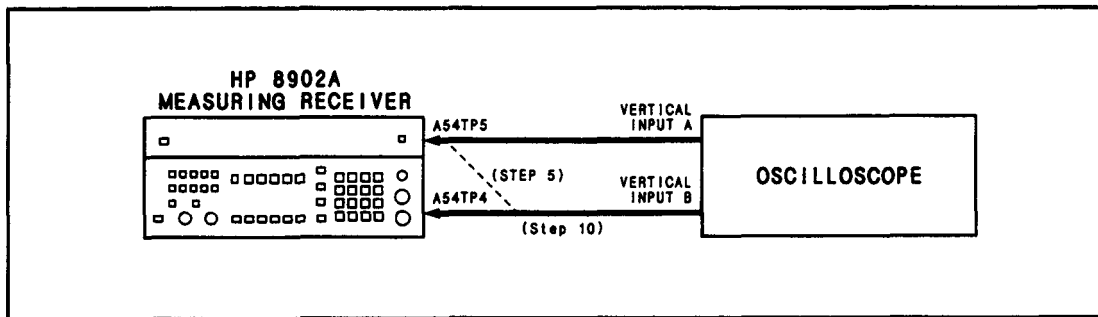
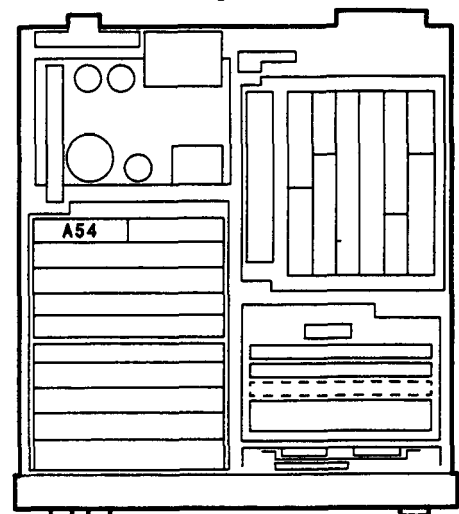

Figure 5-12. IF Synchronous Detector Adjustment Test Setup

Procedure

1. Turn the Measuring Receiver off. Extend the A54 IF Synchronous Detector Assembly. The cables need not be reconnected to the assembly.
2. Turn the instrument back on. Key in 48.7 SPCL to pretune the 455 kHz VCO to 457 kHz and display the VCO frequency. Adjust A54L3 for a display between 45650 and 45750 (that is, 457 ± 0.5 kHz).
3. Key in 48.2 SPCL to read the VCO frequency (but with no pretune voltage applied). Note the frequency drift on display. If the frequency drifts up more than 10 counts (100 Hz) in one minute, adjust A54R17 (Φ DET OFS) clockwise approximately 1 turn (and vice versa for drift down).
4. Key in 48.7 SPCL and 48.2 SPCL again and repeat step 3 until the frequency drift is within limits.



NOTE

If using the optional Gain/Phase Meter, perform optional steps 5a-7a instead of steps 5-11. Continue with step 12.

5. Connect both channels of an oscilloscope through two 10:1 divider probes to A54TP5. See Figure 5-12. Set the coupling of both channels to ac. Set both channels to 10 mV per vertical division (combined with the probes the total vertical sensitivity will be 100 mV per division). Set the triggering to channel A. Set the sweep time to 20 ns per division (use a magnifier if needed).
6. On the Measuring Receiver, key in 48.7 SPCL.
7. On the oscilloscope, adjust the horizontal position to locate the zero crossing of channel A. Set the input switch for channel A to ground. Adjust the vertical position of channel A to center the trace of channel A. Set the input switch for channel A to ac.
8. Set the input switch for channel B to ground. Adjust the vertical position of channel B to center the trace of channel B. Set the input switch for channel B to ac.
9. Note the time difference of the zero-crossing of the two traces. This difference represents the phase error of the two channels. (By momentarily grounding one of the input switches, note which channel leads.)
10. Move the probe of channel B to A54TP4. Adjust the vertical position of channel B to bring the trace of channel B on the display.
11. Adjust A54L4 to center the peak of channel B directly over the zero crossing of channel A plus the error noted in step 9. The centering must be within ± 0.5 horizontal division (that is, ± 10 ns or $\pm 1.7^\circ$). See Figure 5-12. (Momentarily ground the input switch of channel A to check the zero crossing of channel A.)
12. On the Measuring Receiver, key in 48.1 SPCL to display the synchronous detector offset voltage. Adjust A54R76 (SYCH DET OFS) for a reading between -0.0010 and 0.0010 .
13. If the A54U7 Loop Bandwidth Control DAC has been replaced, perform the following procedure.
 - a. Turn the Measuring Receiver off. Unplug the A54 IF Synchronous Detector Assembly.
 - b. Measure the resistance between pins 1 and 16 of A54U7.
 - c. Calculate the resistance (in ohms) of A54R24 by the formula

$$R_{24} = 2150 \times \left(\frac{\text{resistance of step b}}{7736} - 1 \right).$$

- d. Replace A54R24, if necessary, with a resistor of a value within $\pm 10\%$ of the resistance calculated in step c.

Optional Steps

- 5a. On the Gain/Phase Meter set channel A and B input range switches to "2-20V".
Set the Frequency Range switch to "100-1M".
Set the Phase Reference switch to "A".
Set the Amplitude B/Phase switch to "Phase".
- 6a. Connect channel A, through a 1:1 probe, to A54TP5.
Connect Channel B, through a 1:1 probe, to A54TP4.
- 7a. Adjust A54L4 for a $90.0^\circ \pm 0.5^\circ$ phase difference reading. (Continue with step 12.)

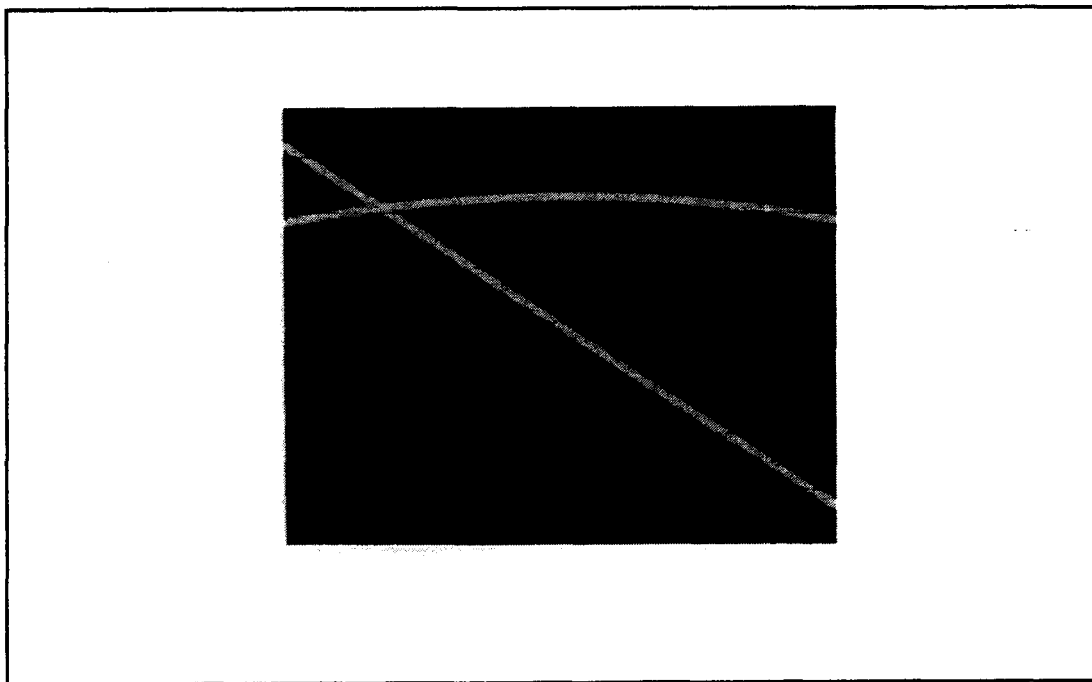

Figure 5-13. IF Synchronous Detector Adjustment Waveform

INDEX

%

% CAL FACTOR,
 in AM measurements, 3-167
 RF power calibration, 3-75

--

--, 3-105, 3-116, 3-101, 3-194, 3-285, 3-288
 -- --, 3-105, 3-116, 3-101, 3-285
 -- -- --, 3-105, 3-116, 3-101, 3-285

0

0.001 dB resolution, 3-281
 0.1 Hz resolution, 3-281

1

1 mW power reference oscillator, 3-75
 1 kHz DISTN, 3-229, 3-233
 1.5 MHz IF frequency, 3-151
 1.5 MHz IF detector, 3-259
 10 MHz time base, 3-3

4

400 Hz DISTN, 3-233, 3-229
 455 kHz IF detector, 3-259
 455 kHz IF frequency, 3-151

5

50 MHz reference calibration factor, 3-75

7

750 us de-emphasis, 3-188

A

absolute tuned RF level measurements, 3-95
 accounting for external attenuation, 3-131
 accuracy, in RF power measurements, 3-75
 adjacent-channel power measurements, 3-122, 3-119
 agile frequency sources, measuring, 3-139, 3-145
 AM, 3-161
 affected by IF level, 3-109
 ALC response time, 3-165
 as dB down from the carrier, 3-248
 calibration, 3-167
 increasing accuracy of measurements, 3-163
 OUTPUT, 3-163, 3-173
 attenuation, external; compensating for, 3-131
 attenuation, selecting, 3-265
 attenuator measurements, 3-115

audio detector, 3-201
 response, 3-276
 response time, 3-205
 AUDIO DISTN, 3-229
 audio filters, 3-207
 AUDIO FREQ, 3-227
 AUDIO INPUT, 3-215, 3-227, 3-229
 audio level measurements, 3-229
 audio range selection, 3-275
 audio range, 3-211
 AUTO TUNING, 3-141
 automatic cal factors, 3-75
 automatic level control, 3-276
 AUTOMATIC OPERATION, 3-237
 automatic tuning, 3-141
 average tuned RF level measurements, 3-95

C

CALIBRATE,
 In AM measurements, 3-167
 In FM measurements, 3-181
 RF power calibration, 3-75
 Tuned RF level calibration, 3-95
 calibration factors, AM, 3-279
 calibration factors, FM, 3-279
 calibration factors, RF power, 3-75, 3-78, 3-283
 Automatic, 3-75
 example HP-IB program for entering, 3-85
 frequency-dependent, 3-75
 Manual, 3-83, 3-84, 3-106
 resolution, 3-83
 tuned RF level, 3-99, 3-283
 calibration,
 AM, 3-167, 3-278
 FM, 3-181, 3-278
 RF power, 3-75
 cellular radio measurements, 3-119
 channel accuracy, checking, 3-149
 CLEAR, 3-241, 3-26
 used with HP-IB, 3-18, 3-22
 comparing frequencies, 3-147
 compensating for external attenuation, 3-131

D

dB and frequency resolution, 3-281
 dB EXT ATTEN, 3-131
 de-emphasis, 3-187
 DETECTOR, 3-201
 detector response time, 3-205
 DISABLE ERROR, 3-267
 display averaging, tuned RF level, 3-107
 DISPLAY FREQ INCR, 3-141
 DISPLAY FREQ, RF power calibration, 3-75
 down converter, using the 8902 as, 3-130
 down-converting a microwave signal, 3-255
 drifting signals, measuring, 3-147

E

entering RF power calibration factors, 3-76
 error 02, 3-265
 error 03, 3-265
 error 04, 3-213, 3-269
 error 05, 3-200
 error 06, 3-90
 error 07, 3-269
 error 11, 3-248
 error 17, 3-288
 error 24, 3-14
 error message disable control, 3-267, 3-277
 error message summary, 3-285
 external attenuation (dB), 3-131, 3-280
 external audio rms level measurement, 3-281, 3-229
 external LO, using an, 3-255
 external LO, 3-279

F

filters, RF and IF, 3-259
 filters, audio, 3-207
 firmware date codes 234.1985 and below, 3-82, 3-99, 3-100
 3-105, 3-106, 3-157, 3-205, 3-228, 3-234,
 3-276, 3-281, 3-282, 3-283,
 flatness, measuring, 3-143
 flatness, modulation; checking, 3-248
 FM calibration, 3-181
 FM DE-EMPHASIS, 3-187
 FM OUTPUT, 3-191
 FM, 3-177
 FM, deviation relative to 75 kHz, 3-248
 FREQ ERROR, 3-147
 FREQ ERROR, parts per million display, 3-149
 FREQ OFST TTL OUT, 3-255, 3-257
 FREQ, 3-137
 frequency agile sources, measuring, 3-139, 3-145
 frequency dependent calibration factors in RF power, 3-75
 frequency offset control, 3-255, 3-280
 frequency resolution, 3-157
 frequency tuning, 3-141
 fuses, 3-2

G

gain, external; compensating for, 3-131
 gain, IF, 3-263
 gain, selecting, 3-265

H

high-selectivity power measurements, 3-119
 HP FILTER, 3-207
 HP-IB address, 3-279

HP-IB,

8901A/02A code differences, 3-46
 8902 automatically selects pre-display, 3-202
 abort, 3-33
 address, 3-34
 alpha characters, 3-13
 ASCII characters not used, 3-14
 capabilities, 3-19, 3-21, 3-22
 CLEAR key, 3-22
 clear, 3-239, 3-25
 code sequence, 3-16
 codes, 3-38, 3-39
 commas, 3-13
 data output, 3-18
 device clear, 3-25
 example program for RF power cal factor entry, 3-85
 example, 3-17
 invalid characters, 3-14
 local, 3-26
 measurement example, 3-17
 pass control, 3-33
 peak hold cycles, 3-203
 remote, 3-26
 RF power calibration, 3-83
 service request, 3-27
 spaces, 3-13
 SRQ mask, 3-31
 SRQ, 3-27
 status byte, 3-32
 syntax, numeric, 3-16
 syntax, programming, 3-15
 take control, 3-33
 trigger codes, 3-17
 trigger, 3-22
 turning off functions, 3-14
 using the tone-burst receiver, 3-194

I

IF average detector, 3-96
 IF detector selection, 3-99
 IF filters, 3-259
 IF frequency, 3-151, 3-282
 IF gain, 3-263, 3-277
 IF LEVEL, 3-109
 IF LEVEL, affects AM accuracy, 3-109
 IF OUTPUT, 3-129
 IF OUTPUT, used to check for spurious signals, 3-130
 IF synchronous detector, 3-96
 image frequencies, 3-144
 impedance, source, 3-83
 increment steps, 3-142, 3-143
 input attenuation and gain, 3-265
 INPUT FREQ, 3-141
 INSTR PRESET, 3-239
 internal checks, 3-239
 internal voltmeter; used to make measurements, 3-91

K

kHz \uparrow , kHz \downarrow , 3-141

L

level measurements, scaling, 3-131
 level, relative measurements, 3-95, 3-115
 limit, 3-249, 3-278

LO frequency, 3-153, 3-282
 LO INPUT and LO OUTPUT, 3-155
 local lockout, 3-26
 LOG/LIN, 3-245
 losing instrument states, 3-241
 low-level power measurements, 3-95
 low-level signals, increasing sensitivity on, 3-266
 low-noise LO frequency tuning, 3-141
 LP FILTER, 3-207

M

manual calibration factors for RF power, 3-83
 manual tuning, 3-141
 measurement codes used in limits, 3-250
 MODULATION OUTPUT, 3-215
 modulation range, 3-211
 multi-channel transmitters, checking channel accuracy, 3-149
 multiple signal sources, measuring, 3-139, 3-145

N

noise correction for tuned RF level measurements, 3-106
 noise effects, residual, 3-219
 noise measurements, single-sideband, 3-119
 normalizing noise measurements, 3-119

O

offset in input attenuation, compensating for, 3-131
 offsetting the LO, for selective power measurements, 3-119
 option 003, 3-155
 option 030, 3-119, 3-279, 3-280

P

parts per million display; frequency error measurements, 3-149
 peak detectors,
 in AM measurements, 3-163
 in FM measurements, 3-180
 peak tuned RF level, 3-113, 3-282
 phase lock, LO does not, 3-154
 phase modulation, 3-197
 in degrees, 3-200
 recommended filter selection, 3-200
 phase shift keying, 3-200
 power measurements, low-level, 3-95
 power measurements, RF, 3-75
 power measurements, adjacent channel, 3-119
 power sensor,
 changing, 3-83
 in RF power measurements, 3-75
 user-built, 3-133
 power-up and default conditions, 3-239
 power, relative measurements, 3-95, 3-115
 pre-emphasis equalization, 3-187
 PREVIOUS RATIO, 3-245, 3-278
 program, example for entering RF power cal factors, 3-85
 pull-out cards, 3-2
 pulsed phase modulation, 3-200

R

RANGE HOLD, 3-243
 range, audio, 3-211
 range, modulation, 3-211
 ratio measurements, common, 3-248
 RATIO, with tuned RF level measurements, 3-117

RATIO, 3-245, 3-249
 recalibrating RF power, reasons, 3-82
 RECALL, 3-253
 RECAL,
 in RF power measurements, 3-82
 in tuned RF level measurements, 3-95
 receiver, setting up the 8902 as, 3-269
 recorder output, for RF power measurements, 3-91
 relative tuned RF level measurements, 3-95, 3-115
 remote control RF switch, 3-133
 residual noise effects, 3-219
 resolution, finer for audio frequency measurements, 3-228
 resolution, finer for dB measurements, 3-105
 resolution,
 frequency, 3-157
 RF power calibration factor, 3-83
 RF and IF filters, 3-275
 RF filters, 3-259
 RF frequency error, 3-147
 RF frequency resolution, 3-157, 3-277
 RF frequency tuning, 3-141
 RF input attenuation and gain, 3-265, 3-275
 RF input frequency, 3-137
 RF level measurements, 3-89
 RF level, 3-282
 RF power range, 3-278
 RF POWER, 3-75
 calibration, 3-75
 reasons to recalibrate, 3-82
 using the internal voltmeter with, 3-91
 RF POWER, when initiates RF level measurements, 3-89
 rms calibrated average as peak, 3-248
 rms calibrated average as true average, 3-248
 RMS, 3-229
 RMS detector, considerations when using, 3-180

S

SAVE CAL,
 in AM calibration, 3-167
 in FM calibration, 3-181
 RF power calibration, 3-75, 3-84
 selective power measurements, 3-119, 3-280
 selectivity of tuned RF level measurements, 3-96
 selectivity, increasing, 3-259
 sensitivity,
 increasing, 3-259
 increasing for frequency measurements, 3-138
 increasing on low-level signals, 3-266
 of tuned RF level measurements, 3-96
 sensor module, 3-96
 in RF power measurements, 3-75
 user-built, 3-133
 sensor, power, in RF power measurements, 3-75
 service request, 3-279, 3-27
 SET REF, 3-115
 Used in tuned RF level measurements, 3-95, 3-98, 3-280
 SINAD, 3-233, 3-280
 single-sideband noise measurements, 3-119
 source impedance, 3-83
 special display, 3-272
 special, special display, 3-272

Special Functions, 3-271

- 01, 3-265, 3-275
 - 02, 3-211, 3-275
 - 03, 3-259, 3-275
 - 04, 3-95, 3-95, 3-99, 3-276
 - 05, 3-205, 3-276
 - 06, 3-165, 3-276
 - 07, 3-157, 3-277
 - 08, 3-267, 3-277
 - 09, 3-259, 3-277
 - 10, 3-278
 - 11, 3-245
 - 11.2, 3-278
 - 12, 3-181, 3-278
 - 13, 3-167, 3-278
 - 14, 3-249, 3-278
 - 16, 3-167, 3-279
 - 17, 3-181, 3-279
 - 18, 3-193, 3-279
 - 21, 3-279
 - 22, 3-279, 3-30
 - 23, 3-123, 3-119, 3-279
 - 24, 3-123, 3-119, 3-280
 - 25, 3-131, 3-280
 - 26, 3-115, 3-280
 - 27, 3-255, 3-280
 - 29, 3-233, 3-280
 - 30, 3-229
 - 31, 3-281
 - 32, 3-281
 - 32.9, 3-105
 - 33, 3-153, 3-282
 - 34, 3-151, 3-282
 - 35, 3-89, 3-282
 - 36, 3-113, 3-282
 - 37, 3-75, 3-78, 3-283
 - 38, 3-95, 3-99, 3-283
 - 39, 3-95, 3-99, 3-283
- special special display, 3-272

- spurious signals, check for using the IF output, 3-130
- squelch tone measurement, 3-193
- squelching, automatic if the input signal drops, 3-180
- SRQ, 3-27
- status bit, 3-33
- stepping frequency, 3-142, 3-143
- STORE, 3-253
- switch, remote control RF, 3-133
- synchronous tuned RF level measurements, 3-95

T

-
- table of calibration factors, 3-75
 - table of calibration factors, storing, 3-83
 - time base, 3-3
 - tone-burst receiver, the 8902 as, 3-193
 - tone-burst receiver mode, 3-279
 - track mode tuning for tuned RF level measurements, 3-282
 - TRACK MODE, 3-141
 - track-mode tuning in tuned RF level measurements, 3-105
 - tuned RF level detector selection, 3-96, 3-99, 3-276
 - tuned RF level noise correction, 3-281
 - tuned RF level, peak, 3-113
 - TUNED RF LEVEL, 3-95
 - Display averaging, 3-107
 - Measurements using ratio, 3-117
 - tuning, frequency, 3-141

U

-
- UNCAL, in tuned RF level measurements, 3-97, 3-107
 - user-built sensor module, 3-133

V

-
- voltmeter, internal; used to make measurements, 3-91

Z

-
- ZERO, RF power calibration, 3-75

REGIONAL SALES AND SERVICE OFFICES

NORTH/CENTRAL AFRICA

Hewlett-Packard S.A.
7, Rue du Bois-du-Lan
CH-1217 MEYRIN 2, Switzerland
Tel: (022) 83 12 12
Telex: 27835 hpse
Cable: HEWPACKSA Geneve

ASIA

Hewlett-Packard Asia Ltd.
6th Floor, Sun Hung Kai Centre
30 Harbour Rd.
G.P.O. Box 795

HONG KONG

Tel: 5-832 3211

After Jan. 1, 1984

47th Floor, China Resources Bldg.
26 Harbour Rd., Wanchai

HONG KONG

Telex: 66678 HEWPA HX
Cable: HEWPACK HONG KONG

CANADA

Hewlett-Packard (Canada) Ltd.
6877 Goreway Drive
MISSISSAUGA, Ontario L4V 1M8
Tel: (416) 678-9430
Telex: 610-492-4246

MEDITERRANEAN AND MIDDLE EAST

Hewlett-Packard S.A.
Mediterranean and Middle East
Operations
Atrina Centre
32 Kifissias Ave.
Paradissos-Amarousion, ATHENS
Greece
Tel: 682 88 11
Telex: 21-6588 HPAT GR
Cable: HEWPACKSA Athens

EASTERN EUROPE

Hewlett-Packard Ges.m.b.h.
Lieblgasse 1
P.O. Box 72
A-1222 VIENNA, Austria
Tel: (222) 2365110
Telex: 1 3 4425 HEPA A

NORTHERN EUROPE

Hewlett-Packard S.A.
Uilenstede 475
P.O. Box 999
NL-1180 AZ AMSTELVEEN
The Netherlands
Tel: 20 437771

SOUTH EAST EUROPE

Hewlett-Packard S.A.
7, Rue du Bois-du-Lan
CH-1217 MEYRIN 2, Switzerland
Tel: (022) 83 12 12
Telex: 27835 hpse
Cable HEWPACKSA Geneve

OTHER EUROPE

Hewlett-Packard S.A.
P.O. Box
150, Rte du Nant-D'Avril
CH-1217 MEYRIN 2, Switzerland
Tel: (022) 83 8111
Telex: 22486 hpsa
Cable: HEWPACKSA Geneve

EASTERN USA

Hewlett-Packard Co.
4 Choke Cherry Road
ROCKVILLE, MD 20850
Tel: (301) 258-2000

MIDWESTERN USA

Hewlett-Packard Co.
5201 Tollview Drive
ROLLING MEADOWS, IL 60008
Tel: (312) 255-9800

SOUTHERN USA

Hewlett-Packard Co.
2000 South Park Place
P.O. Box 105005
ATLANTA, GA 30348
Tel: (404) 955-1500

WESTERN USA

Hewlett-Packard Co.
3939 Lankershim Blvd.
P.O. Box 3919
LOS ANGELES, CA 91604
Tel: (213) 506-3700

OTHER INTERNATIONAL AREAS

Hewlett-Packard Co.
Intercontinental Headquarters
3495 Deer Creek Road
PALO ALTO, CA 94304
Tel: (415) 857-1501
Telex: 034-8300
Cable: HEWPACK